



2019 IMMERSION BLENDERS SALAD SPINNERS DICER JUICER





dynamicmixersusa.com
dynamicmixers.ca



DYNAMIC

Invents the Immersion Blender in 1964, a high-end mixer for professional chefs; introduces the Manual Salad Spinner in 1992 and the Manual Dicer in 2000; and relaunches the GIRAFFE Mobile Mixer in 2014.

Offers the largest and most extensive range of Immersion Blenders and accessories on the market.

Runs an integrated production program and selects the best materials ensuring product quality, reliability and durability.

Designs, manufactures and incorporates all components used in the production of its mixers.

Offers the highest level of after-sales service and all spare parts are easily available.

**NO. 1
COMMERCIAL
HAND MIXER
IN THE WORLD!**

MiniPro 



MX070.1

MX070.11

MX070.12

MX070.13

MX070.14

MX070.15

NOW OFFERED IN 5 NEW COLORS !

The **MiniPro** Immersion Blender has been the NO. 1 commercial hand mixer in the world for 10 years straight. To celebrate this 10 year milestone, Dynamic will be offering its most popular mini mixer in five new special edition color combinations : Blue/White, Red/White, Black/White, All White, Grey/White.

MINI SERIES

PAGES 8-9

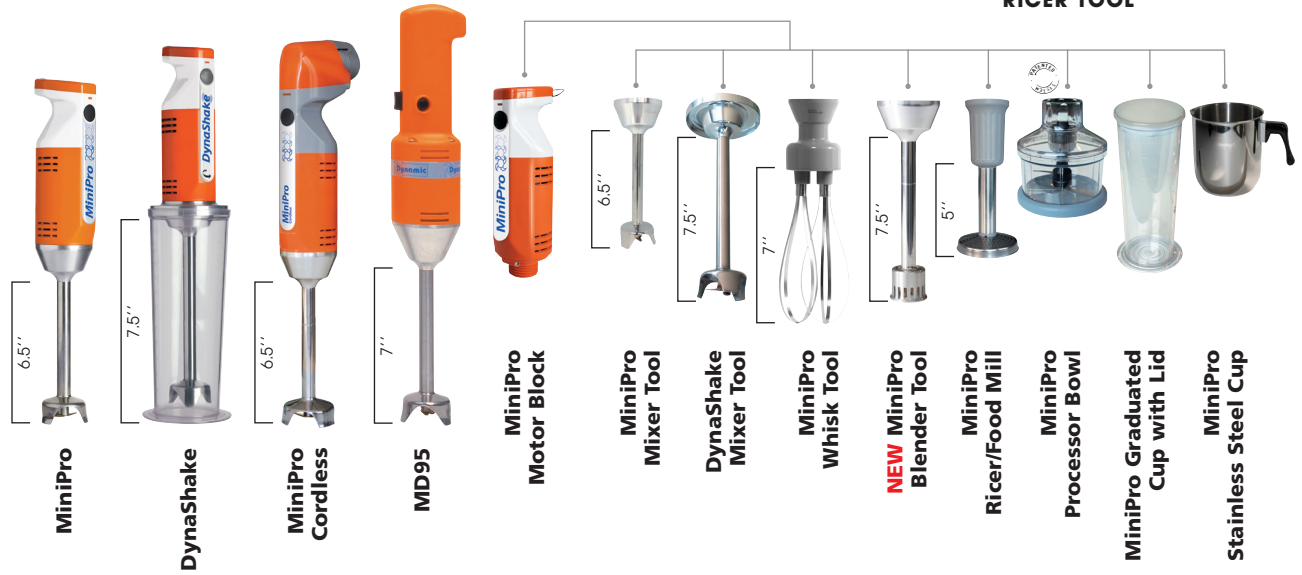

JUNIOR SERIES

PAGES 10-11

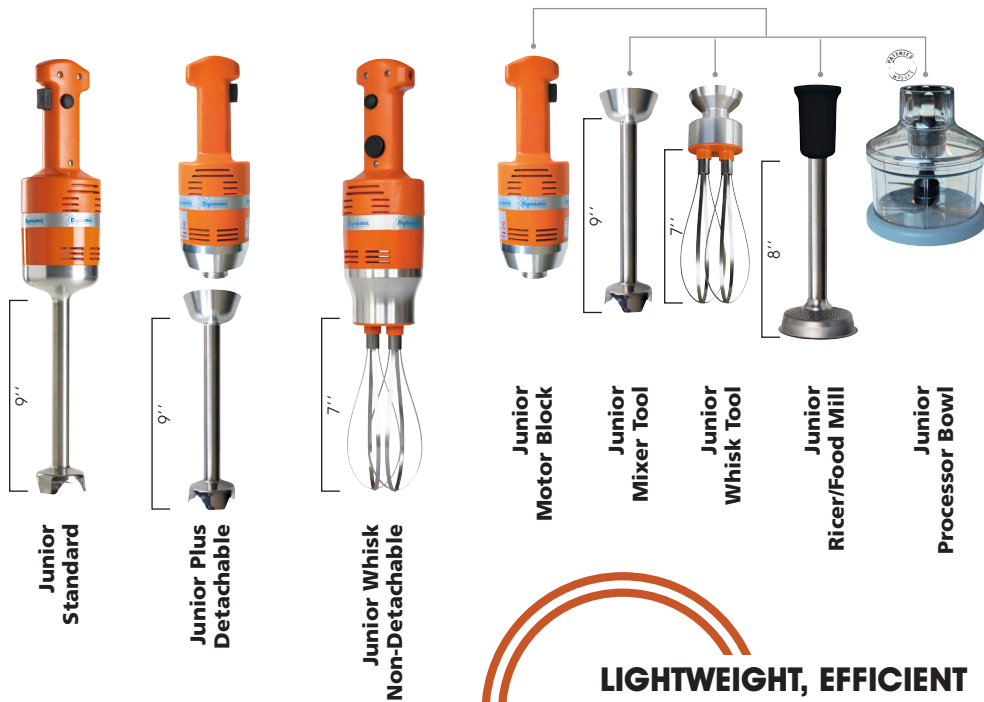

See Junior Combi on page 11

Junior Combi

LIGHTWEIGHT, EFFICIENT AND DEPENDABLE FOR CONTINUAL, CONSISTENT, EVERYDAY MIXING



SENIOR SERIES

PAGES 12-13

See Senior Combi on page 13



**POWER AND
VERSATILITY
ALL IN ONE**

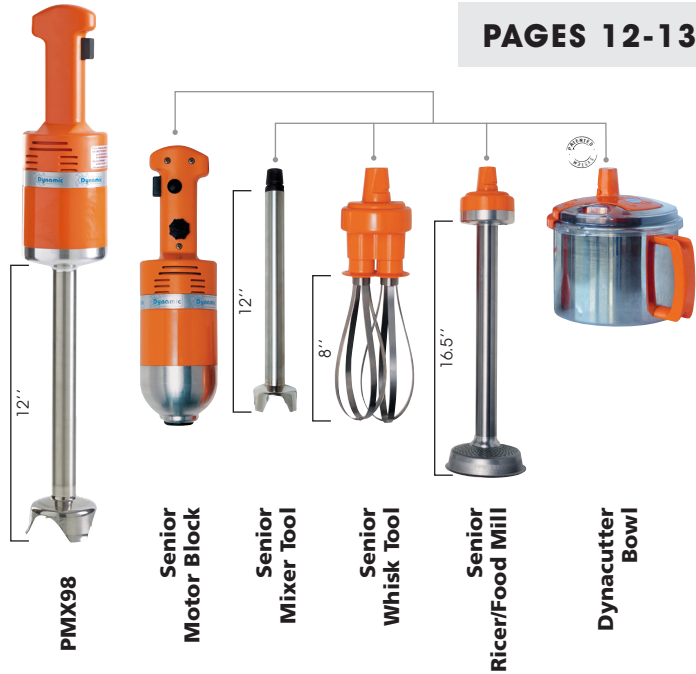

MASTER SERIES

PAGES 14-17

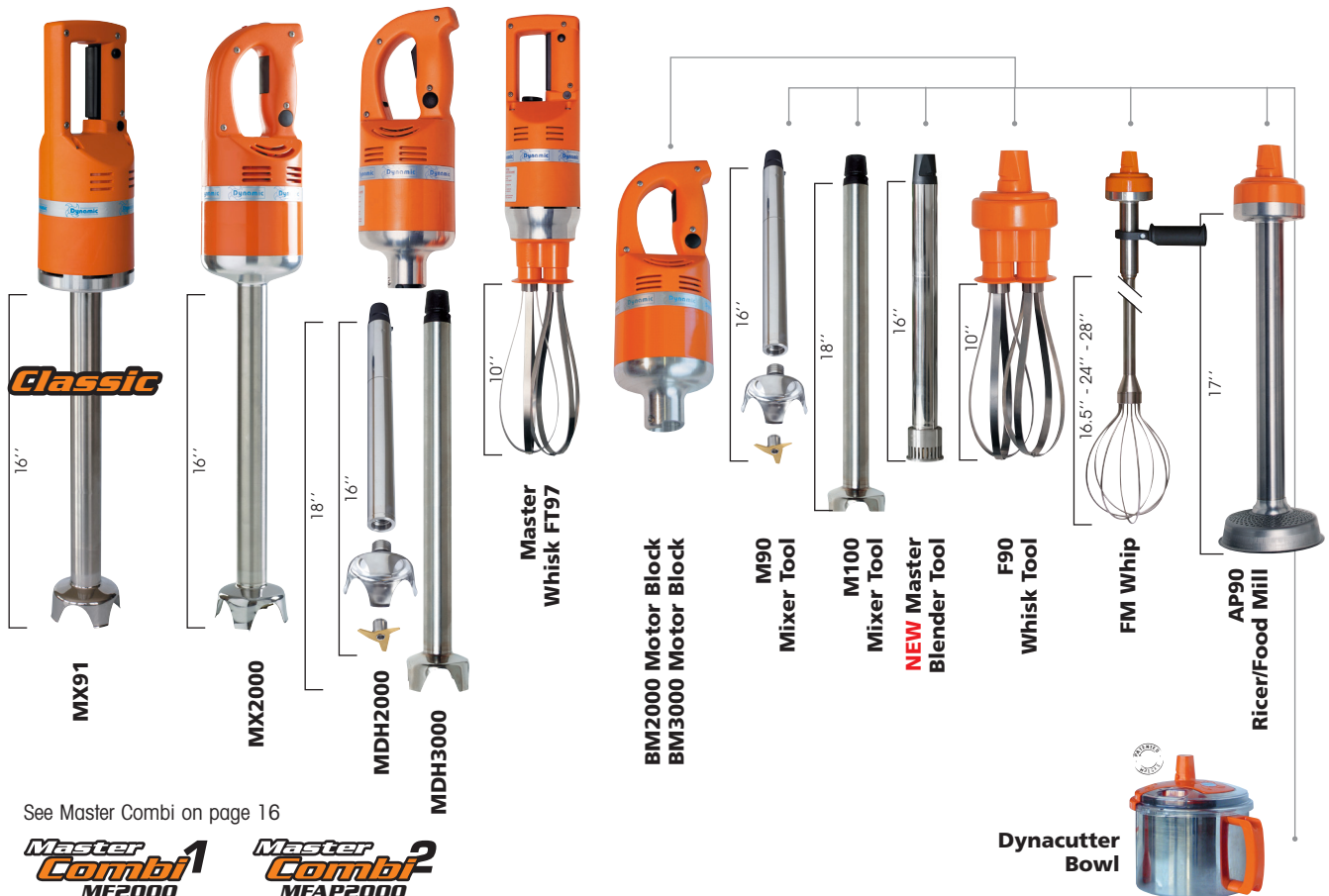

See Master Combi on page 16



SMX SERIES

PAGES 18-19



SMX250ES



SMX350ES



SMX450ES



SMX550ES



SMX650ES



SMX750ES



SMX850ES

Official launch at NRA
May 18-21, 2019



NRA SHOW 2019
THE INTERNATIONAL FOODSERVICE MARKETPLACE

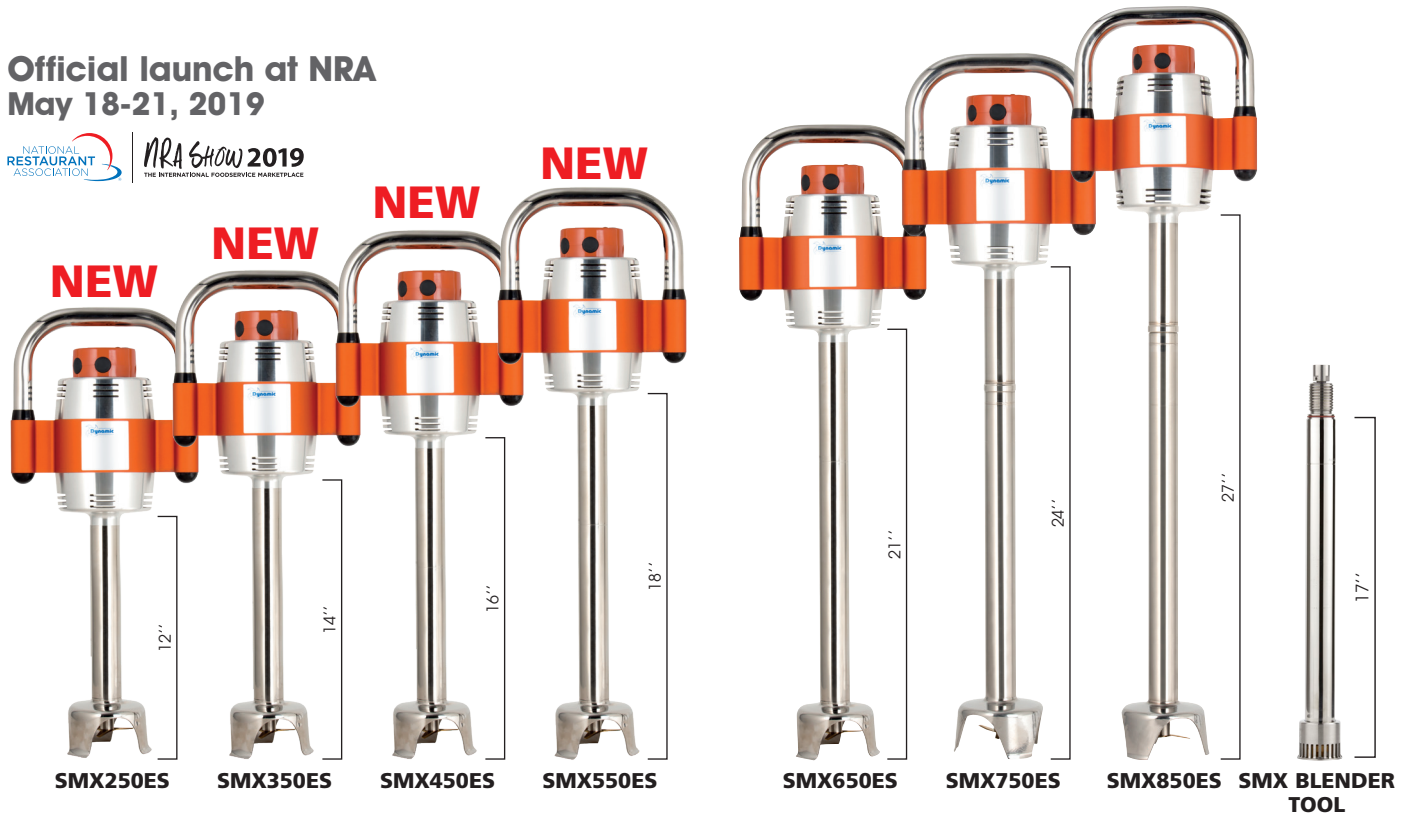

RICER/FOOD MILL

PAGE 20

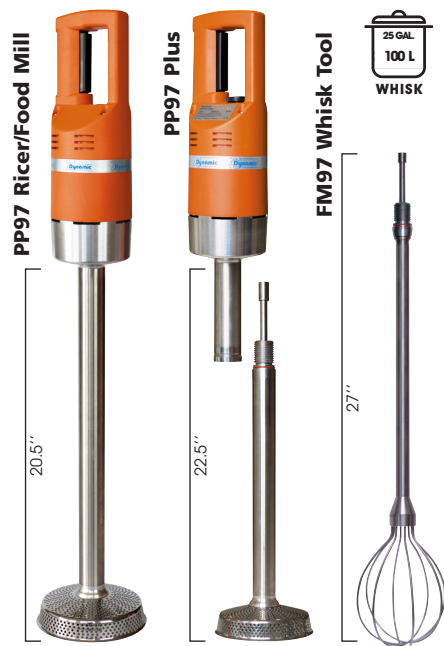

SUPPORT BRACKETS

PAGE 21



CITRUS JUICER

PAGE 21



SALAD SPINNERS

PAGE 24

**DYNAMIC, THE INVENTOR
OF THE COMMERCIAL
SALAD SPINNER**



**SD99
Manual**



**SD92
Manual**

**SD92SC Sealed
Cover Manual**



WITH TIMER AND TOUCH SWITCH



**EM98
Electric**



**SSB1
Stabilizing Base**

MOBILE MIXER



PAGES 22-23



**Power Pro
Giraffe**

MANUAL DICER

PAGE 25



**Dyncube
Manual Dicer**

DYNACUBE

MINI SERIES

MiniPro - MiniPro Cordless MD95



Variable speed

NOW OFFERED IN 5 NEW COLORS

MX070.11

MX070.12

MX070.13

MX070.14

MX070.15



160 mm / 6.5"



160 mm / 6.5"



Option variable speed



160 mm / 6.5"

MiniPro



MiniPro

Reference	MX070.1
Total length	395 mm / 15,5"
Mixer tool length	160 mm / 6,5"
Diameter	70 mm / 2,8"
Actual weight	1,1 Kg / 2,5 lbs
Shipping weight	1,5 Kg / 3,2 lbs
Output	200 W
Speed	0 to 13 000 R.P.M.

MiniPro comes complete with :

- 1 MiniPro mixer
- 1 Emulsifying blade
- 1 Standard blade
- 1 Batter blade
- 1 Dairy blade



Emulsifying cutter blade 0550



Standard cutter blade 0551



Dairy blade 0553



Batter blade 0552

MiniPro Cordless



MiniPro Cordless

Reference	MX135.1
Total length	450 mm / 17,7"
Mixer tool length	160 mm / 6,5"
Diameter	70 mm / 2,8"
Actual weight	1,1 Kg / 2,4 lbs
Shipping weight	1,9 Kg / 4,2 lbs
Output	2000 mAh - 12 Vdc
Speed	10 000 R.P.M.

MiniPro Cordless comes complete with :

- 2 Batteries
- 1 Charger

Battery

Reference	AC585
Run-Time	20 minutes

Charger

Reference	AC590.1
Charge time	45 minutes / battery



Emulsifying blade 9414

MD95

Reference	MX010.1
Blade	Standard

MD95E

Reference	MX008.1
Blade	Emulsifying

Total length	445 mm / 17,5"
Mixer tool length	160 mm / 6,5"
Diameter	72 mm / 3"
Actual weight	1,2 Kg / 2,6 lbs
Shipping weight	1,5 Kg / 3,3 lbs
Output	180 W
Speed	9 500 R.P.M.

MD95 with variable speed

Reference	MX010.1.V
Speed	0 to 9 500 R.P.M.



DynaShake MiniPro Combi Accessories

MINI SERIES

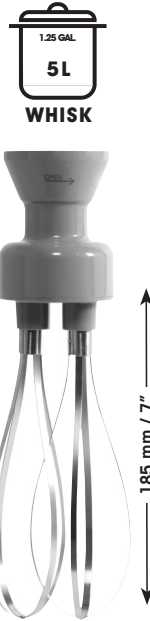

DynaShake®

01 - DynaShake

Reference	MX054.1
Total length	425 mm / 16,7"
Mixer tool length	190 mm / 7,5"
Diameter	95 mm / 3,8"
Actual weight	1,2 Kg / 2,7 lbs
Shipping weight	1,9 Kg / 4,2 lbs
Output	200 W
Speed	0 to 13 000 R.P.M.

DynaShake comes complete with: 1 DynaShake mixer, 1 Emulsifying blade, 1 Standard blade, 1 Batter blade, 1 Dairy blade, 1 litre Graduated Cup + lid

MiniPro Combi

02 - MiniPro Combi

Reference	MX070.2.1
Total length	395 mm / 15,5"
Mixer tool length	160 mm / 6,5"
Whisk length	185 mm / 7"
Diameter	70 mm / 2,8"
Actual weight	1,6 Kg / 3,6 lbs
Shipping weight	2,1 Kg / 4,6 lbs
Output	200 W
Mixer speed	0 to 13 000 R.P.M.
Whisk speed	0 to 2 500 R.P.M.

MiniPro Combi comes complete with: 1 MiniPro mixer, 1 Mixer tool, 1 Whisk tool, 1 Emulsifying blade, 1 Standard blade, 1 Batter blade, 1 Dairy blade

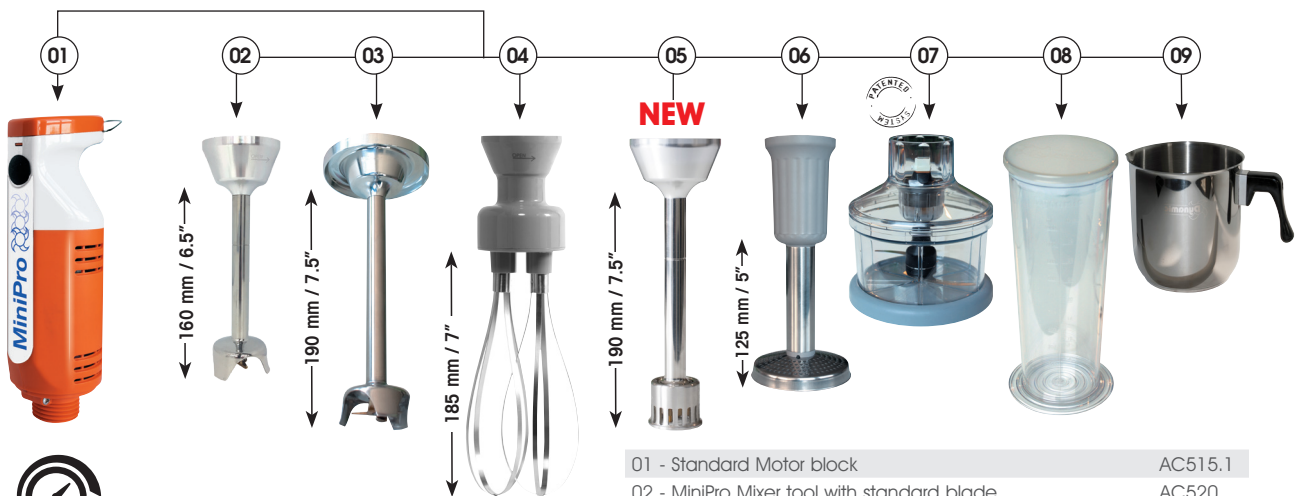

MIXERS **WHISKS** **FOODMILL RICER TOOL** **BOWL**

01 - Standard Motor block	AC515.1
02 - MiniPro Mixer tool with standard blade	AC520
03 - DynaShake Mixer tool with standard blade	AC530
04 - Whisk tool with polycarbonate carter (Capacity: 1-5L)	AC516
05 - NEW MiniPro Blender tool	AC560
06 - Food Mill / Ricer (Capacity: 10 lbs)	AC517
07 - MiniPro Food Processor bowl (Capacity: 0,8 L / 1 qt.)	AC518
08 - Graduated cup with lid (Capacity: 1 L / 40 oz + cover)	AC510
09 - MiniPro Stainless steel cup	AC513

JUNIOR SERIES

Junior Standard
Junior Plus



Option
variable
speed



Variable
speed



ADVANTAGES

- **Performance:** Precise power to weight ratio.
- **Durability:** Stainless steel mixer bell and foot.
- **Usability:** Variable speed.
- **Sanitation:** Easy to clean.
- **Comfort:** Lightweight for easy use.
- **Versatility:** Whisk, Processor bowl, Ricer tool available as separate attachments.
- **Safety:** Push-button safety switch.

Junior Standard non-detachable

Reference	MX020.1
Total length	505 mm / 20"
Mixer tool length	225 mm / 9"
Diameter	94 mm / 4"
Actual weight	1,7 Kg / 3,7 lbs
Shipping weight	2,0 Kg / 4,4 lbs
Output	250 W
Speed	9 500 R.P.M.

Junior Standard non-detachable with variable speed

Reference	MX020.1.V
Speed	0 to 9 500 R.P.M.

Junior Plus detachable

Reference	MX021.1.V
Total length	505 mm / 20"
Mixer tool length	225 mm / 9"
Diameter	94 mm / 4"
Actual weight	1,9 Kg / 4,2 lbs
Shipping weight	2,3 Kg / 5 lbs
Output	250 W
Speed	0 to 9 500 R.P.M.



Junior Whisk - Junior Combi Accessories

JUNIOR SERIES



Junior Combi



01-Junior Whisk non-detachable

Reference	FT005.1
Total length	500 mm / 20"
Whisk length	185 mm / 7"
Diameter	94 mm / 4"
Actual weight	1,4 Kg / 3 lbs
Shipping weight	1,7 Kg / 3,7 lbs
Output	200 W
Speed	0 to 2 000 R.P.M.

02-Junior Combi detachable

Reference	MX022.1
Total length	530 mm / 21"
Mixer tool length	225 mm / 9"
Whisk length	185 mm / 7"
Diameter	94 mm / 4"
Actual weight	2,4 Kg / 5,3 lbs
Shipping weight	3,3 Kg / 7,3 lbs
Output	250 W
Mixer speed	0 to 9 500 R.P.M.
Whisk speed	0 to 2 000 R.P.M.

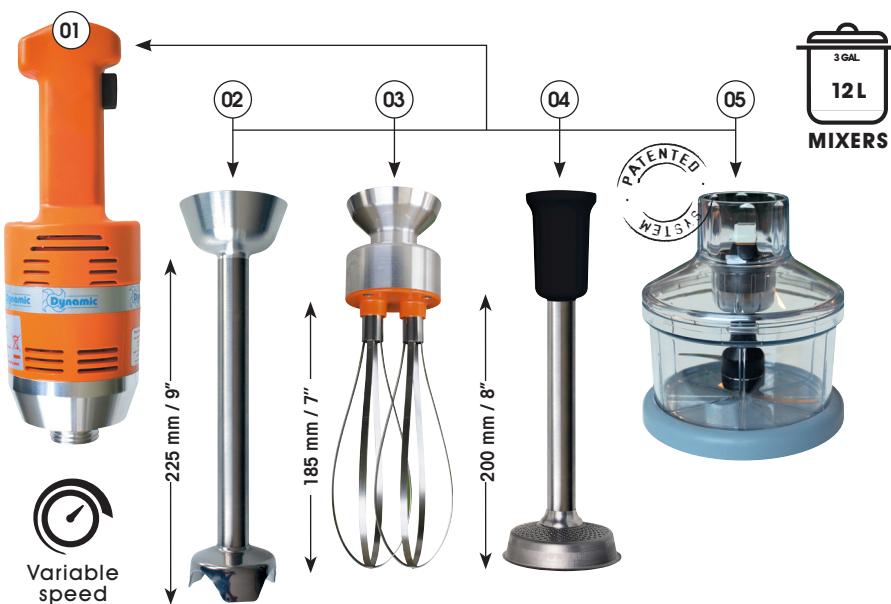

01 - Junior Motor block

Reference	AC100.1
Total length	305 mm / 12"
Diameter	94 mm / 4"
Actual weight	1,9 Kg / 4 lbs
Shipping weight	2,3 Kg / 5 lbs
Output	250 W
Speed	0 to 9 500 R.P.M.

02 - Junior Mixer tool	AC101
03 - Junior Whisk tool	AC102
04 - Junior Ricer / Food Mill	AC103
05 - Junior Processor bowl	AC104

SENIOR SERIES

PMX98
PMDH250



Option
variable
speed



300 mm / 12"



Variable
speed



300 mm / 12"

ADVANTAGES

- Performance: Precise power to weight ratio.
- Durability: Stainless steel mixer bell and foot.
- Usability: Variable speed.
- Sanitation: Easy to clean.
- Comfort: Lightweight for easy use.
- Versatility: Whisk, Processor bowl, Ricer tool available as separate attachments.
- Safety: Push-button safety switch.

PMX98 Standard non-detachable

Reference	MX007.1
Total length	600 mm / 24"
Mixer tool length	300 mm / 12"
Diameter	97 mm / 4"
Actual weight	2,4 Kg / 5,3 lbs
Shipping weight	2,9 Kg / 6,4 lbs
Output	300 W
Speed	9 500 R.P.M.

PMX98 Standard non-detachable with variable speed

Reference	MX007.1.V
Speed	0 to 9 500 R.P.M.

PMDH250 detachable

Reference	MX006.1
Total length	640 mm / 25"
Mixer tool length	300 mm / 12"
Diameter	97 mm / 4"
Actual weight	2,5 Kg / 5,5 lbs
Shipping weight	3,7 Kg / 8,1 lbs
Output	300 W
Speed	0 to 9 500 R.P.M.



Combi PMF250 Accessories

SENIOR SERIES



Precise alignment of motor block and mixer tool requires only a 1/4 turn to secure. Ejectable whisks for easy cleaning.



300 mm / 12"

205 mm / 8"

Senior Combi PMF250

Senior Combi PMF250

Reference	MF003.1
Total length	640 mm / 25"
Mixer tool length	300 mm / 12"
Whisk length	205 mm / 8"
Diameter	97 mm / 4"
Actual weight	3,4 Kg / 7,5 lbs
Shipping weight	4,5 Kg / 9,9 lbs
Output	300 W
Mixer speed	0 to 9 500 R.P.M.
Whisk speed	0 to 900 R.P.M.

Ref. 0880



Convenient and secure :

Wall storage bracket for mixer and accessories included.

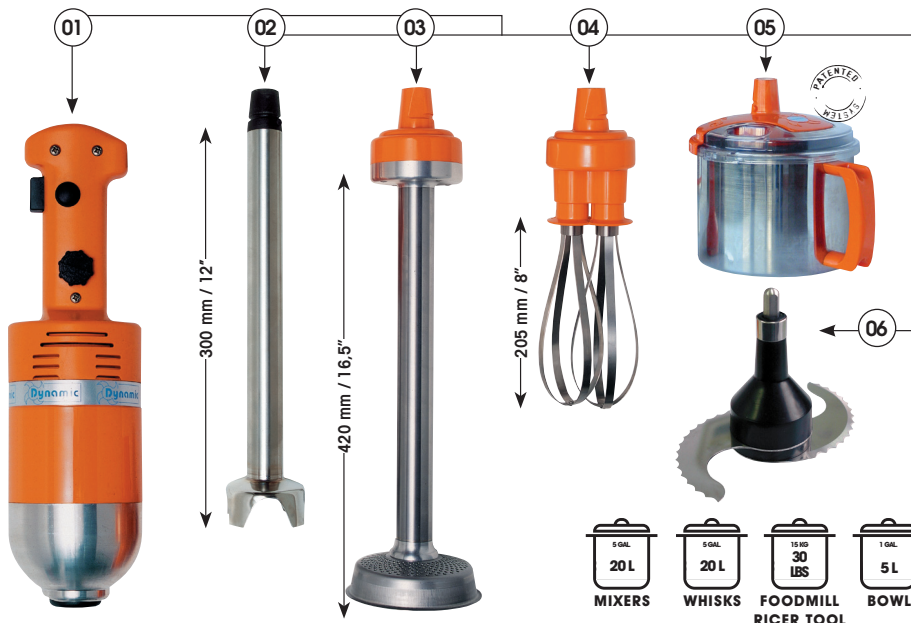

01 - Senior Motor block BM250

Reference	AC005.1
Total length	330 mm / 13"
Diameter	97 mm / 4"
Actual weight	2,0 Kg / 4,4 lbs
Shipping weight	3,1 Kg / 6,8 lbs
Output	300 W
Speed	0 to 9 500 R.P.M.

300 watts motor block can be used with the mixer tool and whisk attachment.

02 - Senior Mixer tool M250	AC006
03 - Senior Ricer / Food Mill	AC004
04 - Senior Whisk F250	AC007
05 - Dynacutter bowl *	AC055
06 - Serrated blade for Dynacutter	AC056

* The complete Dynacutter bowl includes a 5 litre / 6 qt - bowl, cover, reducer and a standard blade or serrated blade.

MASTER SERIES

MX91 Classic



Option
variable
speed



410 mm / 16"

Classic

MX91 Classic non-detachable

Reference	MX005.1
Total length	715 mm / 28"
Mixer tool length	410 mm / 16"
Diameter	110 mm / 4,5"
Actual weight	3,4 Kg / 7,5 lbs
Shipping weight	3,8 Kg / 8,4 lbs
Output	460 W
Speed	9 000 R.P.M.

MX91 Classic non-detachable with variable speed

Reference	MX005.1.V
Speed	0 to 9 000 R.P.M.

ADVANTAGES

- Performance: Precise power to weight ratio.
- Durability: Stainless steel mixer bell and foot.
- Usability: Variable speed.
- Sanitation: Easy to clean.
- Comfort: Lightweight for easy use.
- Versatility: Whisk, Processor bowl, Ricer tool available as separate attachments.
- Safety: Push-button safety switch and continuous run button.
- Output: New motor design for increased efficiency.



MX2000
MDH2000 - MDH3000
FT97

MASTER SERIES



MX2000
non-detachable

Reference	MX004.1
Total length	720 mm / 28,5"
Mixer tool length	410 mm / 16"
Diameter	122 mm / 5"
Actual weight	3,5 Kg / 7,7 lbs
Shipping weight	4,1 Kg / 9 lbs
Output	460 W
Speed	9 500 R.P.M.

MX2000 non-detachable
with variable speed

Reference	MX004.1.V
Speed	0 to 9 500 R.P.M.



Safety button

Continuous function auto run button also allows to mix continuously by pulse.



MDH2000
detachable

Reference	MX003.1
Total length	720 mm / 30"
Mixer tool length	410 mm / 16"
Diameter	122 mm / 5"
Actual weight	3,7 Kg / 8,1 lbs
Shipping weight	4,5 Kg / 9,9 lbs
Output	460 W
Speed	0 to 9 500 R.P.M.

MDH3000
detachable

Reference	MX013.1
Total length	840 mm / 33"
Mixer tool length	457 mm / 18"
Diameter	122 mm / 5"
Actual weight	4,5 kg / 10 lbs
Shipping weight	5 kg / 11 lbs
Output	550 W
Speed	0 to 9 500 R.P.M.



FT97 Master Whisk
non-detachable

Reference	FT001.1
Total length	650 mm / 25,5"
Whisk tool length	245 mm / 10"
Diameter	110 mm / 4,5"
Actual weight	3,3 Kg / 7,3 lbs
Shipping weight	3,7 Kg / 8,1 lbs
Output	460 W
Speed	0 to 900 R.P.M.



Ejectable whisks for easy cleaning.



Wall Support included
Ref. 0881



Emulsifying blade
7910



Mixer Weight Support
Clamp included
with all detachable
Master mixers. **SM020**

MASTER SERIES

Combi MF2000
Combi MFAP2000

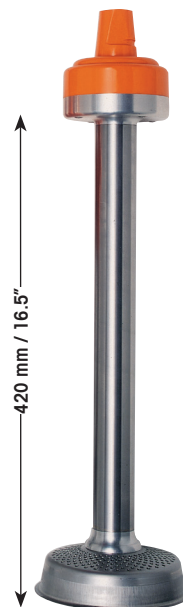
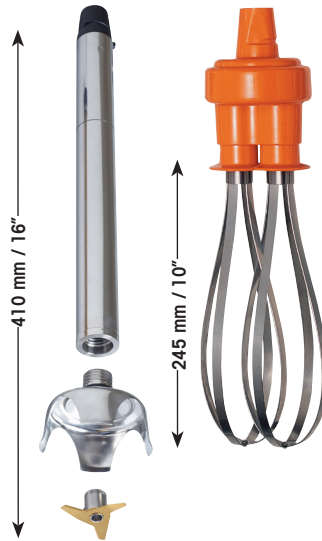
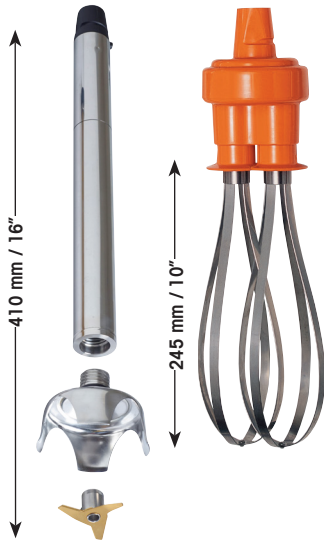

Continuous function auto run button allows to mix continuously or by pulse.



Ejectable whisks for easy cleaning.



Stainless steel perforated grid and blade can be easily dismantled for cleaning.

Master Combi¹ MF2000

Master Combi 1 MF2000 detachable

Reference	MF002.1
Total length	753 mm / 30"
Mixer tool length	410 mm / 16"
Whisk length	245 mm / 10"
Diameter	122 mm / 5"
Actual weight	4,5 Kg / 9,9 lbs
Shipping weight	6,3 Kg / 3,9 lbs
Output	460 W
Mixer speed	0 to 9 500 R.P.M.
Whisk speed	0 to 900 R.P.M.

(Mixer tool + Whisk)

Master Combi² MFAP2000

Master Combi 2 MFAP2000 detachable

Reference	MF001.1
Total length	753 mm / 30"
Mixer tool length	410 mm / 16"
Whisk length	245 mm / 10"
Food Mill / Ricer length	420 mm / 16,5"
Diameter	122 mm / 5"
Food Mill / Ricer diameter	110 mm / 4,5"
Actual weight	6,5 Kg / 14,3 lbs
Shipping weight	8,4 Kg / 18,5 lbs
Output	460 W
Mixer speed	0 to 9 500 R.P.M.
Whisk speed	0 to 900 R.P.M.
Food Mill / Ricer speed	0 to 600 R.P.M.

(Mixer tool + Whisk + Ricer)

Ref. 0880



Convenient and secure :
Wall storage bracket for mixer and accessories included.

Accessories



**THE MOST ADVANCED
AND VERSATILE SERIES
IN THE INDUSTRY**



1A BM2000 Motor block

Reference	AC001.1
Output	460 W

1B BM3000 Motor block

Reference	AC001.1.A
Output	550 W

Total length	350 mm / 13,8"
Diameter	122 mm / 4,8"
Actual weight	2,7 Kg / 6,0 lbs
Speed	0 to 9 500 R.P.M.

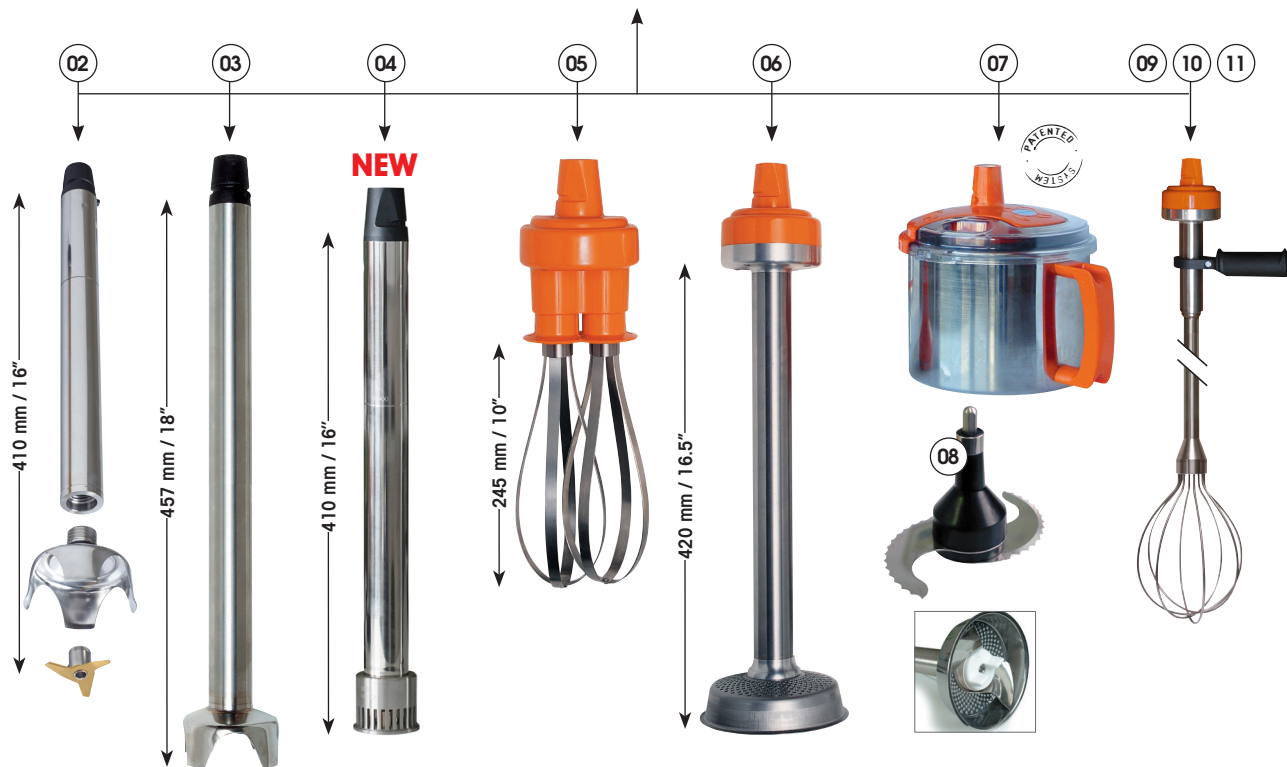

02 - M90 Mixer tool (Weight: 1 Kg / 2,2 lbs)	AC002
03 - M100 Mixer tool	AC500
04 - NEW Master Blender tool	AC070
05 - F90 Whisk (Weight: 0,9 Kg / 2,0 lbs)	AC003
06 - AP90 Food Mill / Ricer (Weight: 1,9 Kg / 4,2 lbs)	AC004
07 - Dynacutter bowl *	AC055
08 - Serrated blade for Dynacutter	AC056

* The complete Dynacutter bowl includes a 5 litre / 6 qt - bowl, cover, reducer and a standard blade or serrated blade.

09 10 11 Master Whip

Reference FM1	AC202
Length FM1	420 mm / 16,5"
Reference FM2	AC200
Length FM2	600 mm / 24"
Reference FM3	AC201
Length FM3	700 mm / 28"
Speed FM1-2-3	0 to 500 R.P.M.

All stainless steel, handle support included.

SMX SERIES

SMX250ES - SMX350ES
SMX450ES - SMX550ES

NEW

**Official launch at NRA
May 18-21, 2019**



NRA Show 2019
THE INTERNATIONAL FOODSERVICE MARKETPLACE



SMX250ES
non-detachable

SMX350ES
non-detachable

SMX450ES
non-detachable

SMX550ES
non-detachable

Reference	MX041.1ES	MX042.1ES	MX043.1ES	MX044.1ES
Total length	575 mm / 22"	626 mm / 24"	676 mm / 26"	728 mm / 28"
Diameter	125 mm / 5"	125 mm / 5"	125 mm / 5"	125 mm / 5"
Actual weight	5,3 Kg / 11 lbs	5,5 Kg / 12,1 lbs	5,7 Kg / 12,6 lbs	5,9 Kg / 13 lbs
Shipping weight	6,8 Kg / 15 lbs	7 Kg / 15,4 lbs	7,2 Kg / 16 lbs	7,4 Kg / 16,3 lbs
Output	600 W	600 W	600 W	600 W
Speed	11 000 R.P.M.	11 000 R.P.M.	11 000 R.P.M.	11 000 R.P.M.

ADVANTAGES

- **Performance:** Precise power to weight ratio.
- **Durability:** Stainless steel mixer bell and foot.
- **Sanitation:** Easy to clean.
- **Comfort:** Lightweight with ergonomic handle design.
- **Safety:** Push-button safety switch and continuous run button.
- **Output:** New motor design for increased efficiency.



1-800-267-7794





SMX650ES - SMX750ES
SMX850ES - Accessories

SMX SERIES

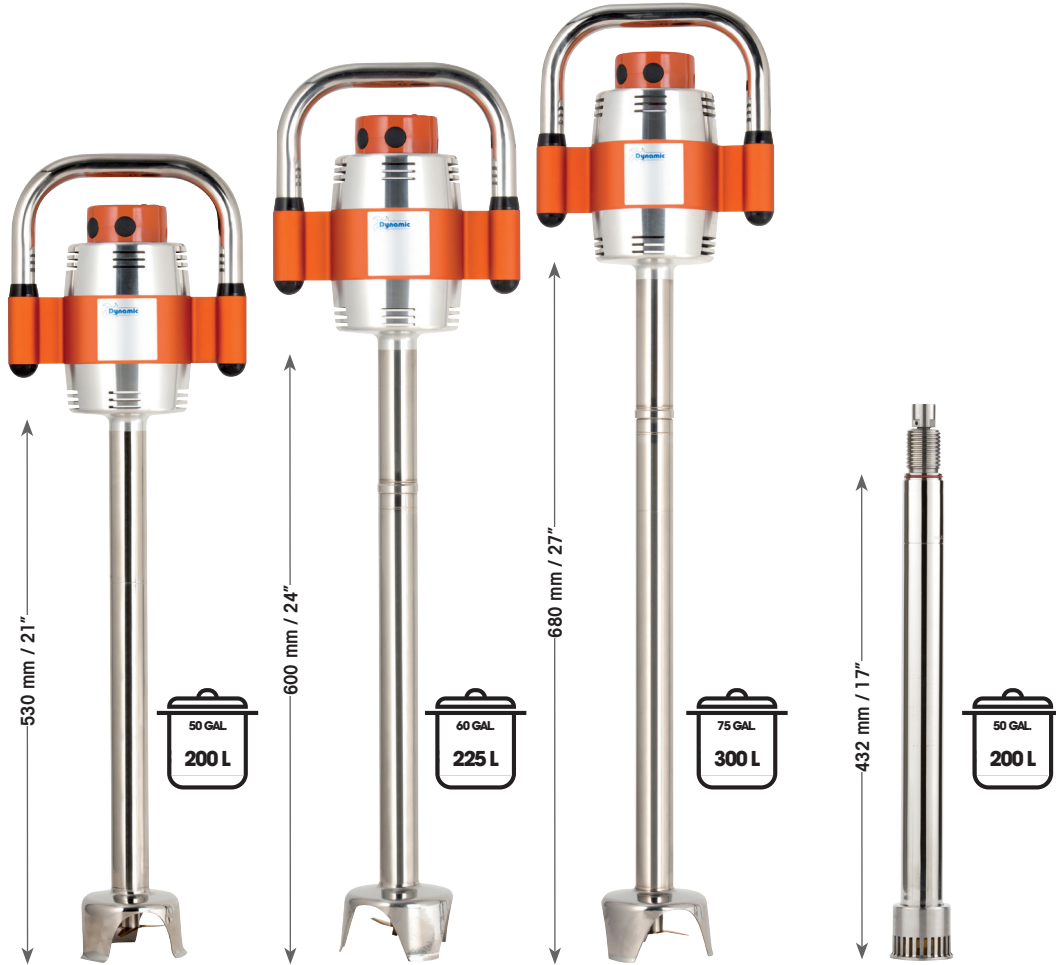

SMX650ES
non-detachable

SMX750ES
detachable
(for maintenance only)

SMX850ES
detachable
(for maintenance only)

SMX BLENDER TOOL
(only for SMX750ES
and SMX850ES)

Reference	MX002.1ES	MX040.1ES	MX001.1ES	AC072T
Total length	800 mm / 31,5"	870 mm / 34"	950 mm / 37,5"	432 mm / 17"
Diameter	125 mm / 5"	125 mm / 5"	125 mm / 5"	-
Actual weight	6,1 Kg / 13,4 lbs	6,5 Kg / 14,3 lbs	6,7 Kg / 14,7 lbs	1,9 Kg / 4,1 lbs
Shipping weight	7,7 Kg / 17 lbs	8 Kg / 17,6 lbs	8,2 Kg / 18 lbs	2,1 Kg / 4,7 lbs
Output	650 W	750 W	850 W	-
Speed	11 000 R.P.M.	11 000 R.P.M.	11 000 R.P.M.	11 000 R.P.M.



Mixer Weight Support
Clamp included. **SM020**



Mixer Weight Support
Clamp included. **SM020**

RICER/FOOD MILL

PP97 - PP97 Plus
FM97 - BM97

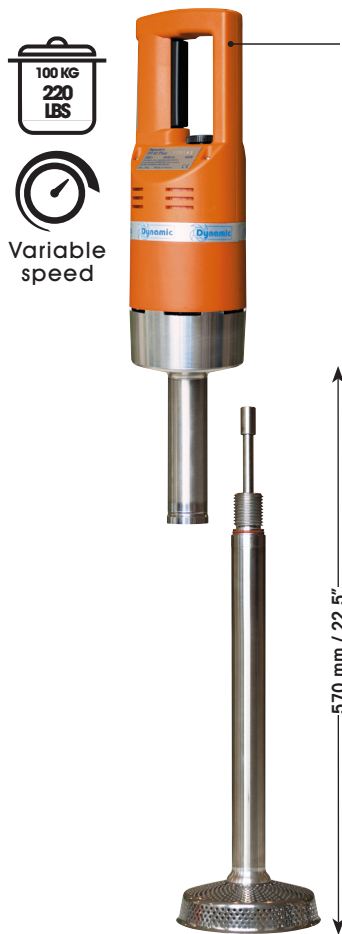
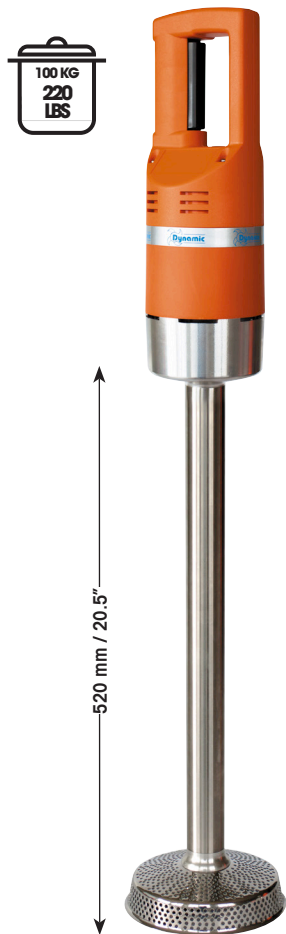

Ricer / Food Mill Motor block BM97

Reference AC221.1
Output 460 W

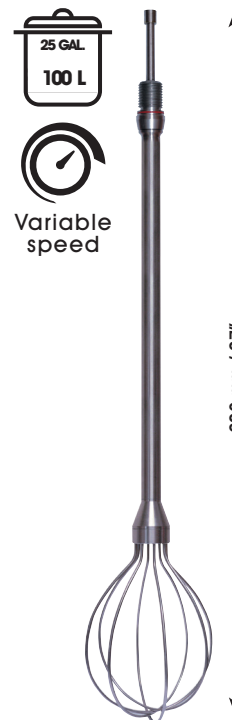

PP97 Ricer / Food Mill non-detachable

Reference	PP001.1
Total length	870 mm / 34"
Mixer tool length	520 mm / 20,5"
Diameter	170 mm / 6,8"
Actual weight	4,9 Kg / 10,7 lbs
Shipping weight	5,9 Kg / 13 lbs
Output	460 W
Speed	0 to 500 R.P.M.

PP97 PLUS Ricer / Food Mill detachable

Reference	PP002.1
Total length	920 mm / 36"
Mixer tool length	570 mm / 22,5"
Diameter	170 mm / 6,8"
Actual weight	4,9 Kg / 10,7 lbs
Shipping weight	5,9 Kg / 13 lbs
Output	460 W
Speed	0 to 500 R.P.M.

FM97 Whisk tool for PP97 PLUS

Reference	AC208
Total length	690 mm / 27"
Actual weight	1,5 Kg / 3,3 lbs

Comes with handle



Stainless steel perforated grid and blade can be easily dismantled for cleaning.



SM
SA

SUPPORT BRACKETS



Mixer Weight Support Clamp included with the Master detachable mixers, the SMX750ES and the SMX850ES.
SM020



Used for weight assist and swivel, never leave mixer unattended.

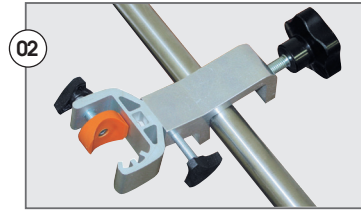

01-Top-Mounted

SM4	Maximum dimension: 400 mm / 16"	Weight: 1,9 Kg / 4,2 lbs	SM001
SM6	Maximum dimension: 600 mm / 24"	Weight: 2,3 Kg / 5 lbs	SM002
SM8	Maximum dimension: 800 mm / 32"	Weight: 2,6 Kg / 5,7 lbs	SM003
SM10	Maximum dimension: 1000 mm / 40"	Weight: 2,8 Kg / 6,2 lbs	SM004
SM12	Maximum dimension: 1200 mm / 48"	Weight: 3,2 Kg / 7 lbs	SM005

All brackets are easily dismantled and can be cleaned in the dishwasher. Adaptable only for Master and SMX series of mixers. Adjustable length. Practical and convenient, allows adjustable height and angle.

02-Side-Mounted

SA	Support brackets «side mounting»	Weight: 0,7 Kg / 1,5 lbs	SM006
----	----------------------------------	--------------------------	-------

All brackets are easily dismantled and can be cleaned in the dishwasher. Adaptable only for Master and SMX series of mixers. Adjustable length. Practical and convenient, allows adjustable height and angle.

CITRUS JUICER

PA96

**PERFECT
FOR ALL YOUR
JUICING NEEDS**

Included



ADVANTAGES

- Ideal for juicing a large volume of lemons, oranges and grapefruit without any effort.
- Capacity of 3 gallons / 12 litres per hour.
- Quiet and very sturdy.
- Easy and quick assembly and disassembly for easy cleaning.



PA96 Citrus Juicer

Reference	PA001.1
Total length	330 mm / 13"
Diameter	220 mm / 8,6"
Actual weight	6,3 Kg / 13,9 lbs
Voltage	115 V or 230 V
Output	200 W
Speed	1 500 R.P.M.

Power Pro Giraffe



**HEAVY DUTY MOBILE
MIXER FOR LARGE
CAPACITY
APPLICATIONS**



FRONT VIEW

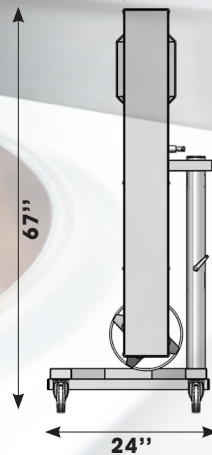

SIDE VIEW

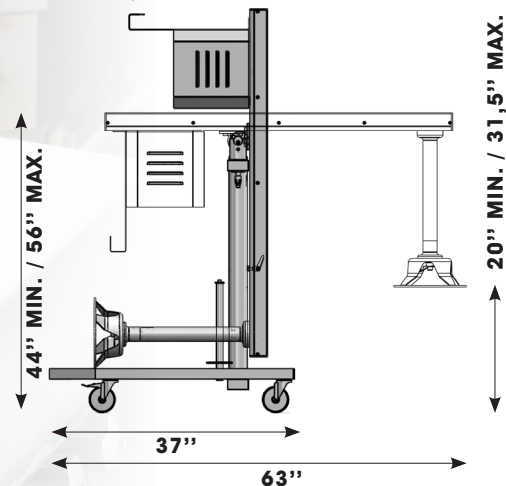

ADVANTAGES

- **Comfort:** Easily maneuverable and transportable with 4 swivel casters.
- **Versatility:** Various accessories.
- **Usability:** Small storage footprint.
- **Sanitation:** 100% stainless steel for easy cleaning.
- **Performance:** Powerful motor of 2,2 KW.

Power Pro Giraffe

Reference	TB002
Voltage	230 V, 3 phase, 50/60Hz
Output	2 200 W
Speed	0 to 4 000 R.P.M.

HEAVY DUTY MOBILE MIXER

Accessories



Power Pro Giraffe Whisk tool

Variable speed compulsory

Reference	TB003
Speed	400 to 600 R.P.M.
Diameter	170 mm / 6,5"
Height	470 mm / 18,5"

The Whisk tool is ideal for delicate recipes and provides the ultimate in mixing flexibility.



Power Pro Giraffe Blender tool

Reference	TB004
Speed	2 800 to 4 000 R.P.M.
Diameter	100 mm / 3,8"
Height	90 mm / 3,5"

The Blender tool is ideal for emulsifying soups and sauces.

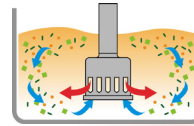

*See images below for texture difference.

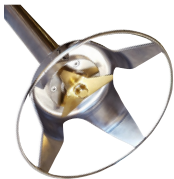

Power Pro Giraffe Mixer tool

Reference	TB012
Speed	2 800 to 4 000 R.P.M.
Diameter	280 mm / 11"
Height	160 mm / 6,5"

The Mixer tool is ideal for mixing large capacity preparations like soups and sauces in less than 5 minutes.



NEW

Power Pro Giraffe Potato Masher tool

Variable speed compulsory

Reference	TB013
Speed	800 to 1 600 R.P.M.
Diameter	147 mm / 5,8"
Height	251 mm / 9,9"

The Potato Masher tool is designed for high volume purées that require 50 to 150 kg of potatoes.



Power Pro Giraffe Pump

Reference	TB030 (TB004 required)
Speed	-
Diameter	178 mm / 7"
Height	90 mm / 3,5"

The Pump allows for an effortless and fast transfer of food preparations. Adaptable on the Blender tool only (sold separately).



Power Pro Giraffe Gun

Reference	TB040 (TB030 required)
Speed	-
Length	202 mm / 8"
Height	243 mm / 9,6"

The Gun can be used as a complementary tool for the transfer of food preparations in smaller containers. Adaptable on the Pump attachment only (sold separately).

*

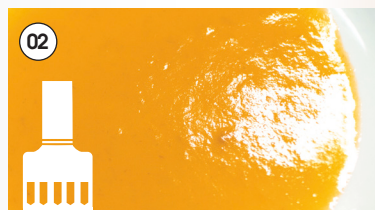

01 - Texture obtained with Mixer tool (TB012). The texture did not evolve and remains slightly rough.

02 - Texture obtained with Blender tool (TB004). The texture is creamy, smooth and perfect.

SALAD SPINNERS

SD99 - SD92
SD92SC - EM98

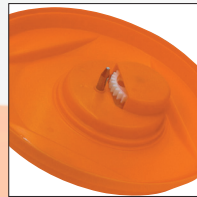

SD92
Cover Lid



SD92SC
Sealed Cover Lid



2.5 GAL
10 L

SD99 Manual salad spinner

Reference	E001
Total height	460 mm / 18"
Diameter	330 mm / 13"
Actual weight	2,4 Kg / 5,3 lbs
Shipping weight	3,1 Kg / 6,8 lbs
Capacity	Maximum 4 heads of lettuce



5 GAL
20 L

SD92 Manual salad spinner

Reference	E002
Total height	530 mm / 21"
Diameter	430 mm / 17"
Actual weight	3,6 Kg / 7,9 lbs
Shipping weight	4,8 Kg / 10,5 lbs
Capacity	Maximum 8 heads of lettuce

SD92SC Manual salad spinner SEALED COVER

Reference	E004
Total height	530 mm / 21"
Diameter	430 mm / 17"
Actual weight	3,6 Kg / 7,9 lbs
Shipping weight	4,8 Kg / 10,5 lbs
Capacity	Maximum 8 heads of lettuce



WITH TIMER AND TOUCH SWITCH



5 GAL
20 L

SSB1 Stabilizing Base
INCLUDED with the EM98.

EM98 Electric salad spinner with stabilizing base SSB1

Reference	E003.1.B.T
Total height	630 mm / 25"
Diameter	430 mm / 17"
Actual weight	8,3 Kg / 18,3 lbs
Shipping weight	10 Kg / 22 lbs
Output	200 W
Speed	500 R.P.M.
Capacity	Maximum 8 heads of lettuce



SSB1 Stabilizing base*

Reference	AC019
Total height	170 mm / 6,7"
Diameter	360 mm / 14,2"

* For SD92, SD92SC and EM98

ADVANTAGES

- **Sanitation:** HACCP compliant and ETL certified for sanitation conforming to NSF standards.
- **Comfort:** Lightweight for easy transporting, cleaning and storage.
- **Performance:** Safe, manual operation and positive affect on operator's food costs.
- **Durability:** Injection molded for precise component fit and finish, weight and balance.

MANUAL DICER

DYNACUBE

DYNACUBE

**N°1 MANUAL DICER
IN THE WORLD**



	Grid set 7 x 7mm / 1/8" x 1/8" with pusher	Grid set 8,5 x 8,5mm / 1/4" x 1/4" with pusher	Grid set 10 x 10mm / 3/8" x 3/8" with pusher	Grid set 14 x 14mm / 1/2" x 1/2" with pusher	Grid set 17 x 17mm / 3/4" x 3/4" with pusher
	AC060	AC061	AC062	AC063	AC064
Dynacube complete	•	•			
CL005	•				
CL003	•		•		
CL006	•		•		
CL008	•			•	
CL009	•				•

Cutting grid sizes are estimates only.

Dynacube

Total height	330 mm / 13"
Diameter	400 mm / 15,8"
Actual weight	3,1 Kg / 6,8 lbs
Shipping weight	4,4 Kg / 9,7 lbs

ADVANTAGES

- Performance: Safe, manual operation and consistent cut with 100% product yield.
 - Sanitation: Easy to clean.
 - Comfort: Quick assembly and disassembly. Foldable legs for convenient storage.
 - Versatility: Ultimate versatility with various dice sizes.
- Preparation flexibility beyond vegetables. Great for fruits and meats.
- Safety: Patented cutting grid system. No direct contact with the blade.

TERMS AND CONDITIONS

PRICING. All prices are subject to change without notice. Prices do not include freight, handling or delivery charges, air shipment charges or taxes (sales, excise, duties, etc.). The Purchaser shall be responsible for collecting and/or paying any and all such taxes. Such charges may, at Dynamic's sole and exclusive discretion, be prepaid by Dynamic and reimbursed by the Purchaser.

APPLICABLE POLICIES FOR RESALE OF PRODUCTS. All product selling prices are determined at the discretion of authorized distributors with the exception of specific products determined by Dynamic to have Minimum Advertised Pricing («MAP»). Failure to comply with our MAP Policy may affect your status as an authorized distributor. Dynamic reserves the right to take the necessary steps in maintaining our integrity with regards to our pricing.

ORDERS. No minimum orders required. Each order must reference Dynamic's quote (if any), the requested Products, and any other information requested by Dynamic. All orders and transactions are subject to acceptance or cancellation by Dynamic, in Dynamic's sole discretion. Each accepted order will be interpreted as a single agreement, independent of any other orders. All orders must be sent by email at orders@dynamicmixers.com or by fax at 1(877)668-6623.

SHIPPING AND DELIVERY. Freight Prepaid qualifies at \$2,800 net on individual orders shipped to one location (Power Pro Giraffe excluded). Orders not meeting Dynamic's Freight Prepaid criteria are F.O.B. Memphis, Tennessee, USA or F.O.B. Montreal, Quebec, Canada. A drop ship fee may apply to any order on shipments to a different destination than their billing address. Shipping and delivery dates are provided as estimates only and Dynamic is not responsible for any early or delayed shipment or delivery. Dynamic may ship parts of an order separately. Dynamic reserves the right to select alternative carriers for all shipments. Freight charges will be billed based upon the weight of the Product(s) ordered and the destination zip code. The risk of loss or damage to the Products in transit shall fall upon the Purchaser, whose responsibility it shall be to file claims with the carrier and/or the insurance company. The Purchaser must notify Dynamic within seven (7) days from the date of their invoice or acknowledgement if they believe any part of their order is missing, wrong, or damaged. Failure to so notify Dynamic will be deemed acceptance of the Products shipped.

RETURNS. Returns cannot be accepted without a Return Authorization number issued by Dynamic and a return request must be submitted within seven (7) days of invoice date. Product returns must be in original packaging and unopened. Damaged and/or used Products will not be accepted. A 25% restocking charge will apply on all returns. Products deemed «Special Order» cannot be returned.

INVOICING AND PAYMENT. Dynamic may invoice parts of an order separately, or may invoice purchases of Products in one invoice. Invoices are due and payable within the time period noted on the Purchaser's invoice. All Products sold remain the exclusive property of Dynamic until invoice is paid in full.

WARRANTY. Dynamic will guarantee all new Products to be free from defects in materials and workmanship. Electric Products include a one (1) year parts and labor carry in bench warranty with the exception of component replacements necessary through regular "wear and tear". Manual Products include a one (1) year limited parts warranty. Warranty is valid, providing the Products have been used in accordance with Dynamic's operating recommendations and guidelines. Dynamic or any authorized service center will repair or replace, at Dynamic's discretion and after examination, any or all manufacturer's defective parts during the warranty period. Any damage caused by improper use, abuse, dropping, or similar accidental damage resulting in breakage will render the warranty null and void. During the warranty period, only Dynamic or one of its authorized service centers may perform evaluations or repairs to Products. Warranty will be void on any equipment which has been dismantled or tampered with during the warranty period if this has been done by unauthorized centers or personnel.

DISCLAIMER. Specifics contained herein with regards to Product text and/or Product images may change without notice.



Handwriting practice sheet for the word "Eminence". The word is written vertically in a large, outlined font on a background of horizontal lines. The letters are: E, m, i, n, e, n, c, e.

USA

1320 ROUTE 9 #1352
CHAMPLAIN, NY - 12919
PHONE (800) 267-7794
FAX (877) 668-6623
INFO@DYNAMICMIXERS.COM
DYNAMICMIXERSUSA.COM

CANADA

3227 BOUL. PITFIELD
MONTREAL, QUEBEC - H4S 1H3
PHONE (514) 956-0127 / (800) 267-7794
FAX (877) 668-6623
INFO@DYNAMICMIXERS.COM
DYNAMICMIXERS.CA

A NADIA GROUP COMPANY

 facebook.com/dynamicmixers

 [@dynamicmixers](https://instagram.com/dynamicmixers)