

2026

■ PARTS CATALOG - US



INDIVIDUAL PART ORDER :

All orders must include the following criteria :

- model of machine • serial number
- description of the part • part number

NORTH AMERICAN DISTRIBUTION

Toll free phone : 1 (800) 267-7794

Email: info@dynamicmixers.com

CONDITIONS OF REPAIRS OR SERVICE (after sale service) :

Please return the machine to the following address :

USA : Dynamic USA

1320 route 9 # 1352, Champlain, NY, 12919

www.dynamicmixersusa.com

Or call us Toll Free 1-800-267-7794 for the nearest authorized service center.

For machines under warranty

Freight charges to the service centers remain the responsibility of the client. Return freight will be paid by Dynamic USA.

For machines not under warranty

- All freight charges remain the responsibility of the client.
- For all repairs not under warranty, an estimate will be completed and returned to the customer (via fax), for approval.
- Labor rate: A standard labor rate of 95,00 \$ / hr will be applied to all repairs not under warranty.
- All service work completed by Dynamic USA will be warranted for a period of three (3) months after date of repair.
- A fee of 95,00 \$ will be charged for all estimates performed, which have been declined by the client, and who request the machine to be returned to them assembled.

Returns

Returns are not accepted without prior written or verbal authorization from Dynamic USA. All returns are subject to a 25% restocking charge. Special order items are non-refundable.

Payment terms

All orders are subject to a net thirty (30).

TERMS & CONDITIONS :

This price list is effective for the year 2026, and supersedes all other price lists. Prices are subject to change without notice. Dynamic USA is not responsible for damage caused due to shipping. Should an item arrive damaged, please contact the factory immediately, so that a claim can be processed. Dynamic USA will utilize the courier company of its choice, unless otherwise specified by the customer, in which an account number must be provided.

HOW TO ORDER :

Toll free phone : 1 (800) 267-7794

Email: orders@dynamicmixers.com

MIXERS

	Page
MINIPRO	4
MD 95	8
JUNIOR STANDARD	9
JUNIOR PLUS	10
MMX 98	17
PMX 83	18
PMX 98	19
PMDH 250	20 & 21
MX 79	22
MX 85	23
MX 91	24
MX 2000	25
MDH 460	26
MDH 2000	27
MDH 3000	28
MX 2000 DSC 230 / 115 V - 50 / 60 Hz	29
SMX 450	42 & 43
SMX 500	44 & 45
SMX 502 - 600	46 & 47
SMX 600 E	48 & 49
SMX 650 ES	50 & 51
SMX 600 DSC 115 V	52 & 53
SMX 700 E	54 & 55
SMX 750 ES	56 & 57
SMX 800 E	58 & 59
SMX 800 DSC 115 V	60 & 61
SMX 850 ES	62 & 63

CORDLESS MIXER

MINIPRO CORDLESS	5
MPX 94 - Mini cordless	15

WHISKS

JUNIOR WHISK	13
FD 98	14
FT 97	30
FT 86	31
FT 79	32

CORDLESS WHISK

FTP 94 - Mini whisk cordless	16
------------------------------	----

MULTI-FUNCTION

JUNIOR COMBI	10 & 11
PMF 250	20 & 21
MF 90	33, 35 & 36
MF 2000	34, 35 & 36
MFAP 90	33, 35 & 36
MFAP 2000	34, 35 & 36

RICER

PP 84	38
PP 97	39
PP 97 +	40 & 41

ACCESSORIES

MINIPRO ACCESSORIES	6 & 7
JUNIOR ACCESSORIES	12
RICER TOOL AP 90 / FM Series	37
SMX BLENDER	64

CITRUS JUICER

PA 96	70
-------	----

GIRAFFE

POWER PRO	65, 66, 67, 68, 69
-----------	--------------------

GIRAFFE MIXER

GM 93	71
-------	----

SALAD SPINNERS

MANUAL SALAD SPINNER SD 99	72
MANUAL SALAD SPINNER SD 92	72
ELECTRIC SALAD SPINNER EM 98	73
ELECTRIC SALAD SPINNER EM98 WITH TIMER	74
MANUAL SALAD SPINNER SD 92 SC SEALED COVER	76 & 77

SUPPORTS

SM4, SM6, SM8, SM10, SM12	70
---------------------------	----

VEGETABLE CUTTERS

FOOD CUTTER CF 2000	71
DYNACOUPE	78
DYNACUBE	79

Mixer MINIPRO

Parts list	Code
Regular blade	0551
Double lip waterproof seal	0632
Self-lubricating ring	0637
Pins 3 x 20	0744
Handle screws (2)	079958
Cover	2840
Hook	2841
Power cord 115V	2842.1
Right handle	2843
Shaft and sprocket	2844
Minipro foot assembly + bushing + seal	2845
Coupling	2846
Motor 230V	2847
Motor 115V	2847.1
Minipro label	2848.1
Left handle	2849
Screws + washers + handle nuts (2)	2850
Handle	2851
Circuit board	2852.1
ID label (230V)	2853
ID label (115V)	2853.1

Parts list	Code
Motor bracket	2854
Screws for motor bracket (2)	2855
Dynashake foot assembly + ring + seal	2856
Shaft and bearing (Dynashake)	2857
Variator knob	2858
Driving shaft joint	2859
Strain relief 115 V	2861.1
Fan	2865
Coupling hub	45123
Rubber button cap	45710

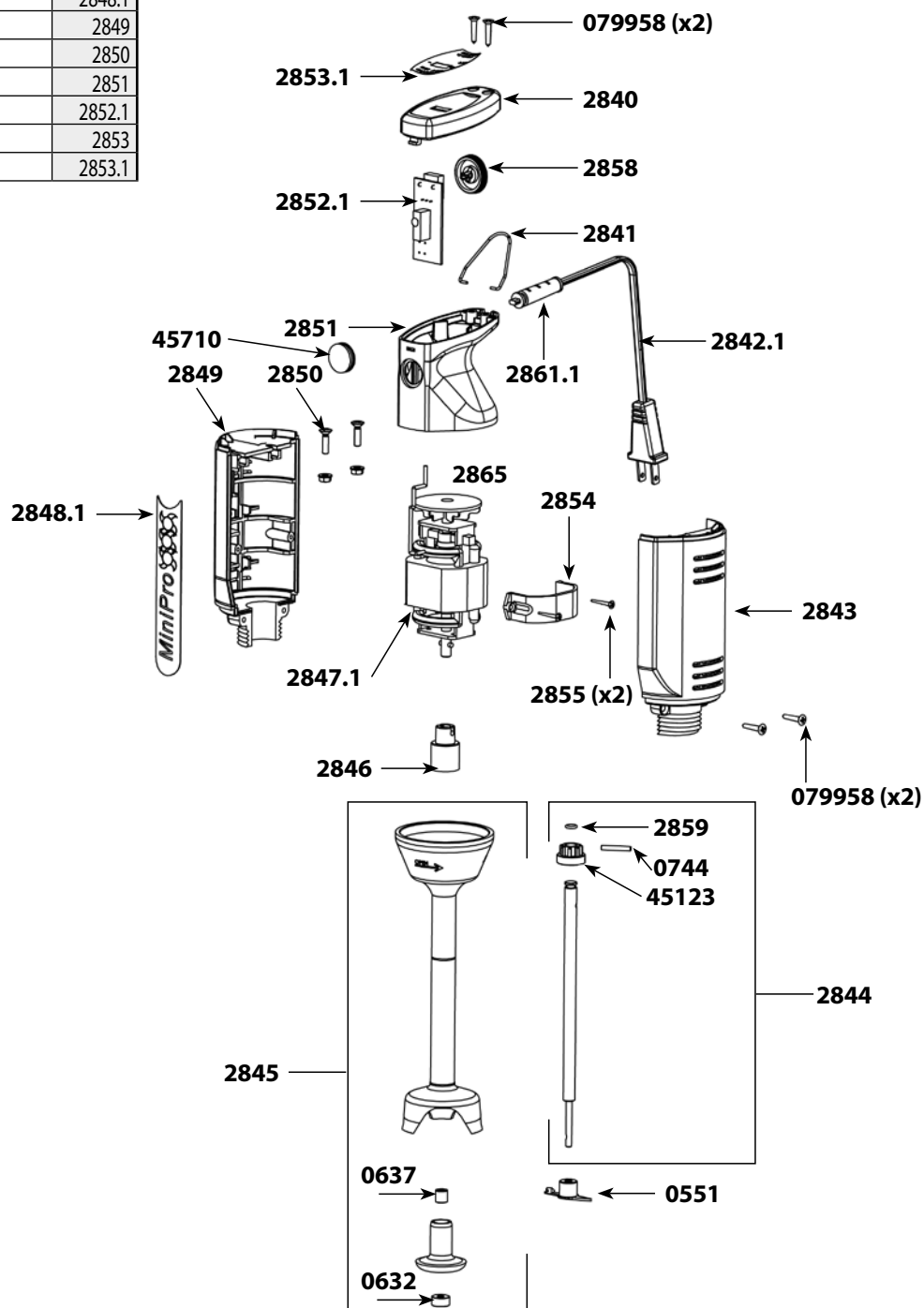

Motor block MiniPro Cordless - Ref AC580

Parts list	Code
Right handle	2843
Left handle	2849
Screws + washer + handle nuts (2)	2850
Screws for motor belt (2)	2855
Battery housing	2900
Terminal support	2901
Motor support	2902
Motor belt	2903
Coupling	2904
Centraliser + screws	2905
Label	2906
Hood	2907
Circuit board	2908
ID label	2909
Screw	2910
12V DC Motor	9408
Handle cap protectors	45710
Handle screws (2)	079958
MiniPro Cordless battery (see machine catalog)	AC585
MiniPro Cordless battery charger 230 V (see machine catalog)	AC590
MiniPro Cordless battery charger 115 V (see machine catalog)	AC590.1

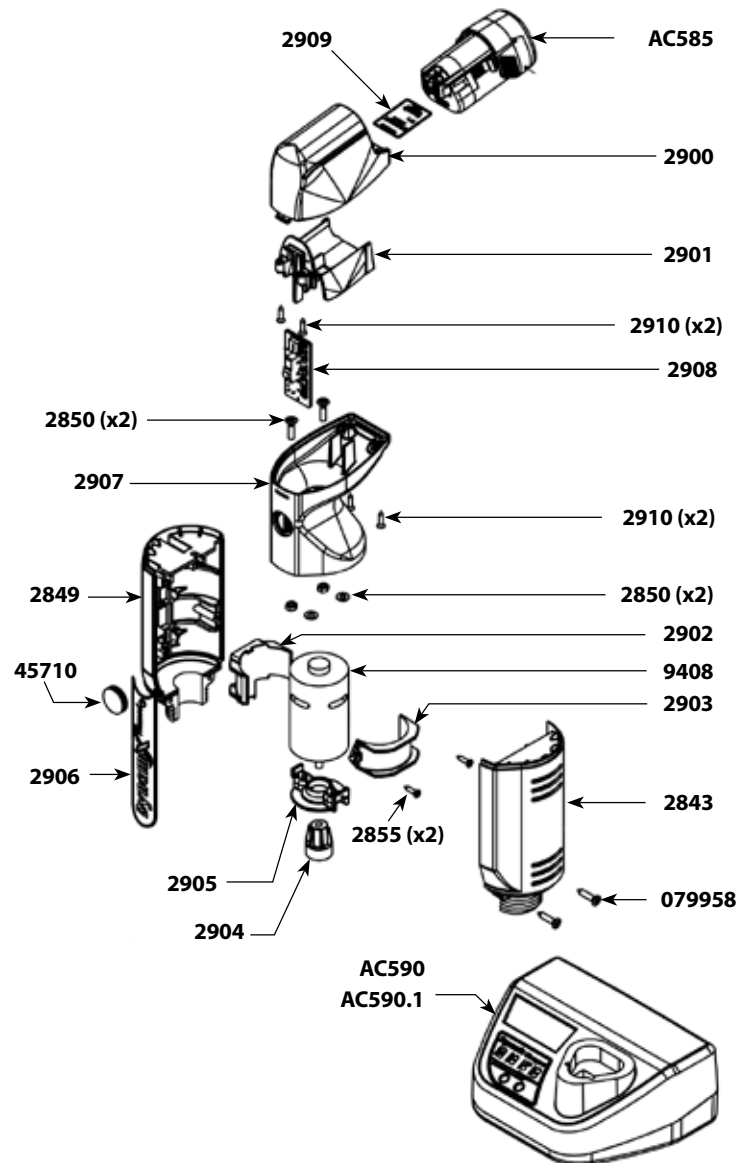

Parts list

Code

Food Processor Bowl

Equipped cover	2880
Blade	2881
Bowl	2882
Base	1178

Equipped lid 2880

Equipped upper shaft	2885
Handle screws (4)	2886
Reduction plate + ring	2887
Lid + reduction gear	2888
O. ring (x4)	2871
O. ring	0658

Blade 2881

Equipped cone	2884
A blade	08999904
Blade holder	1176
B blade	08999905
Set of screws (x3)	9502

Blender AC560

Self-lubricating ring	0666D
Waterproof seal	0667D
Pin (3 x 20)	0744
Foot assembly	1421
Blender bell	1422
Blender blade	1423
Shaft	1424
Blender key	1425
Driving shaft joint	2859
Coupling hub	2860

Blade

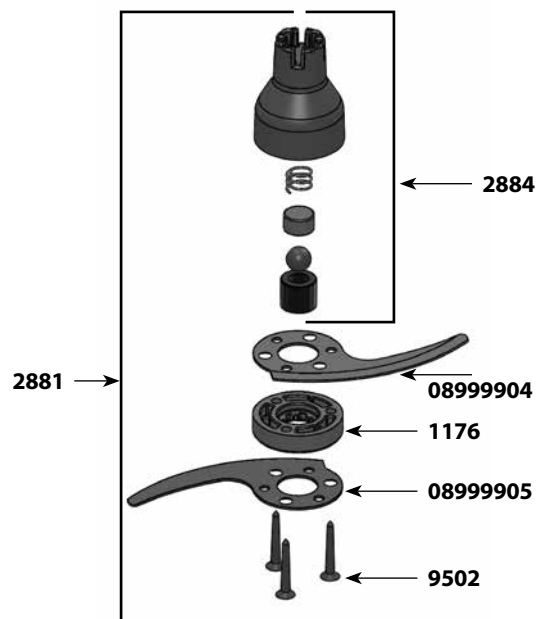

Equipped lid

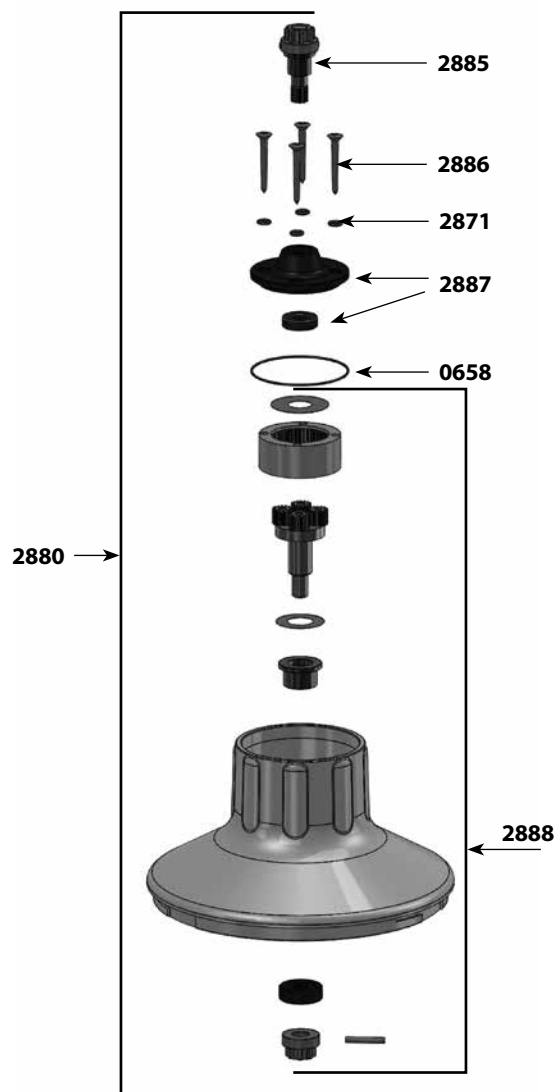

Food Processor Bowl

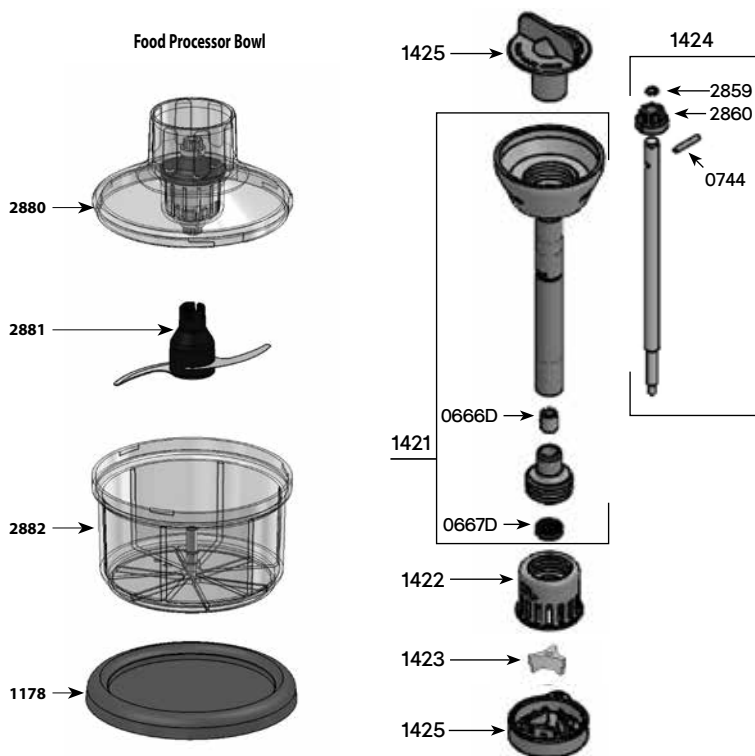

Parts list
Potato Ricer assembly

Parts list	Code
Handle screws (4)	2870
O. ring (x4)	2871
Ricer inferior carter	1179
Equipped upper shaft	2872
Secured washer	1181
Interior geared crown	2873
Equipped output shaft	2874
Equipped spacer for potato ricer	2875
Nut holder + nut	2876
Potato grid	089940
Grid holder	1195
Potato blade	08995
Compression washer	1196
O. ring	0650

Parts list
Whisk assembly

Parts list	Code
Lower motor whisk housing	2890
Equipped output axle w/ 2 gears+pins	2891
Holder assembly w/ 3 self-lubricating rings	2892
Whisk tool (2)	2893
Reduction gear assembly (without whisk)	2894
Equipped upper shaft	4020
Equipped plate with rings	4021
Holder assembly screws	4022
Middle gear & axle	9420

Potato Ricer assembly

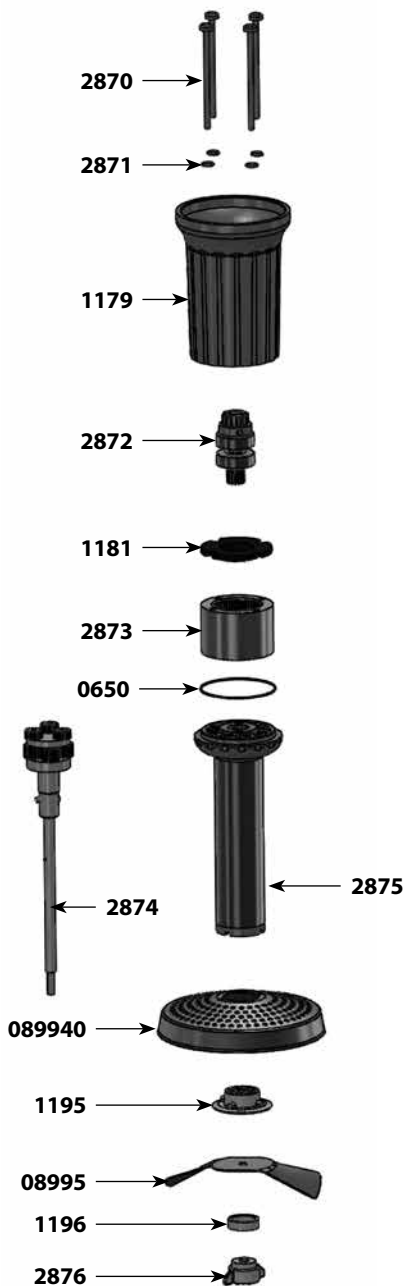

Ricer grid assembly



Whisk tool dismantling

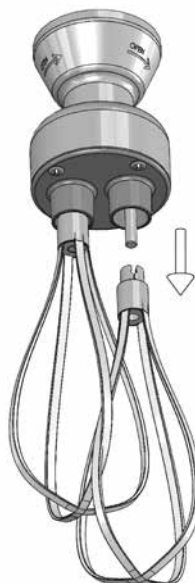

Whisk assembly

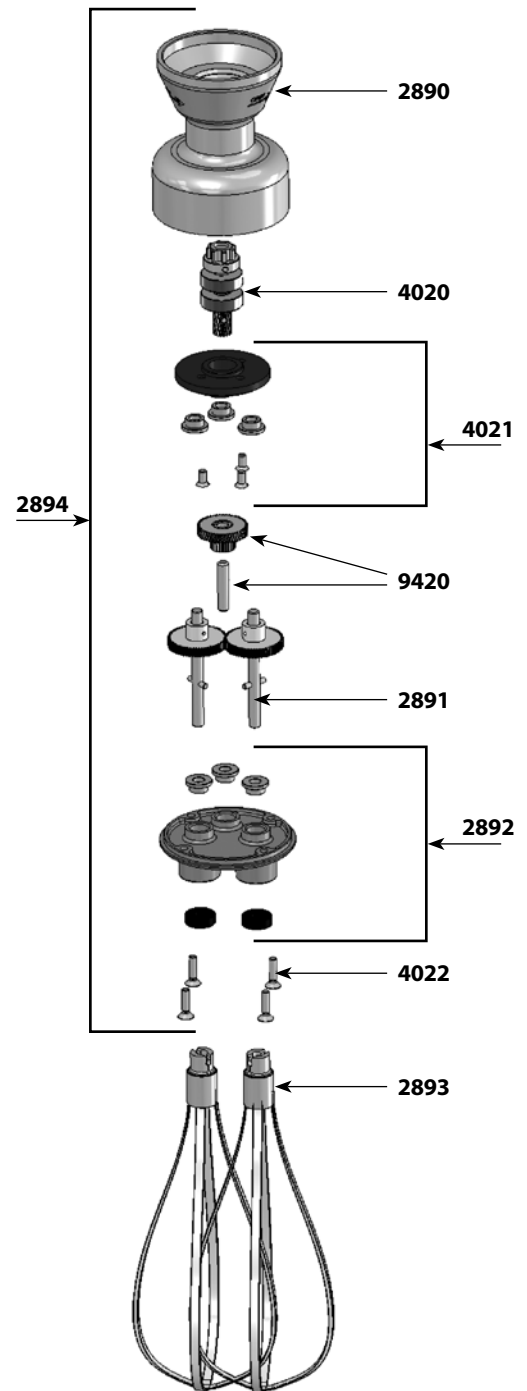

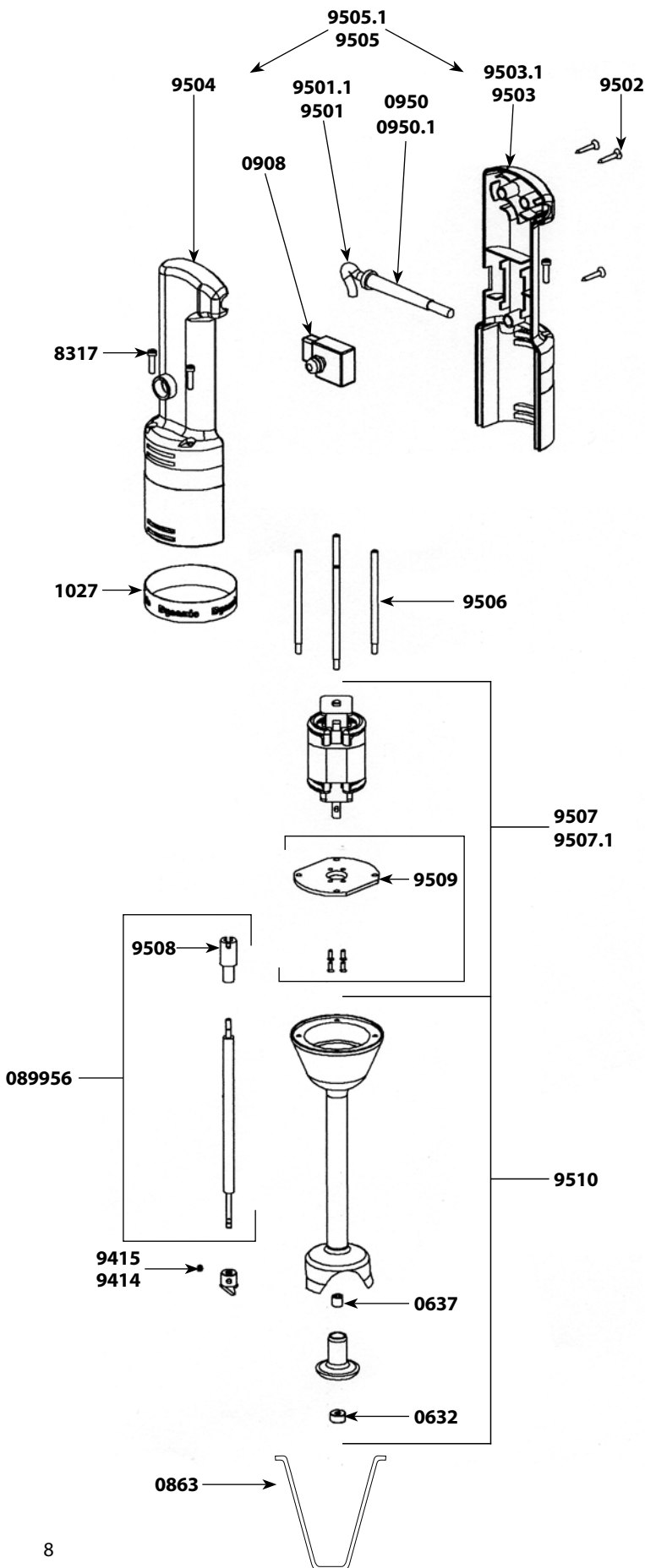

Parts list

Code

Waterproof seal	0632
Bushing	0637
Hook	0863
Complete stainless steel shaft + coupling	089956
Non-locking switch	0908
Filtering Capacitor	0909
Strain relief 230V	0950
Strain relief 115V	0950.1
Dynamic label	1027
Spacer screws (4)	8317
Emulsifying blade	9414
Cutter blade w/screw	9415
Power cord 230 V	9501
Power cord 115 V	9501.1
Handle screws (3)	9502
Lower handle w/ label 230 V	9503
Lower handle w/ label 115 V	9503.1
Upper half handle	9504
Complete handle 230 V (w/sticker, screws, logo, switch, strain relief, power cord)	9505
Complete handle 115 V (w/sticker, screws, logo, switch, strain relief, power cord)	9505.1
Spacer rods (4)	9506
Motor & screw & capacitor 230 V	9507
Motor & screw & capacitor 115 V	9507.1
Coupling sleeve	9508
Motor holder w/4 screws	9509
Foot assembly w/ bearing (exc. shaft + blade)	9510
Motor brushes (2) 230 V	9512
Motor brushes (2) 115 V	9512.1

Parts list	Code
Motor 230 V	0535
Motor 115 V	0535.1
Waterproof seal	0632
Bushing	0642
Stainless steel shaft + coupling	0870
Wall bracket	089959
Non-locking switch	0908
Strain relief 230 V	0950
Strain relief 115 V	0950.1
Dynamic label	1027
Label w/ serial number 230 V	1081
Label w/ serial number 115 V	1082
Complete handle 230 V	4000
Lower half handle w/ label 230 V	4001
Lower half handle w/ label 115 V	4001.1
Upper motor housing	4002
Foot assembly w/ bearing (exc. Shaft + blade)	4003
Cutter blade	4004
Spacer rods (4)	4005
Ball bearing sleeve	4006
Coupling sleeve	4007
Filtering capacitor	4008
Emulsifying blade	4009
Carbon brushes (2) 230 V	4050
Carbon brushes (2) 115 V	4050.1
Spacer screws (4)	7903
Power cord 230 V	9011
Power cord 115 V	9040
Handle screws (3)	9502
Upper half handle	9812
Switch protector	9813

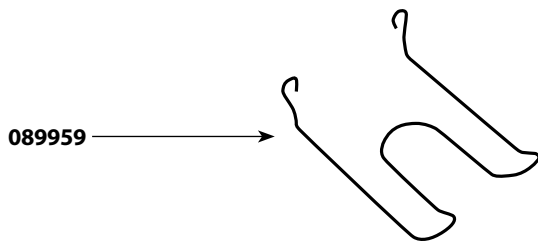
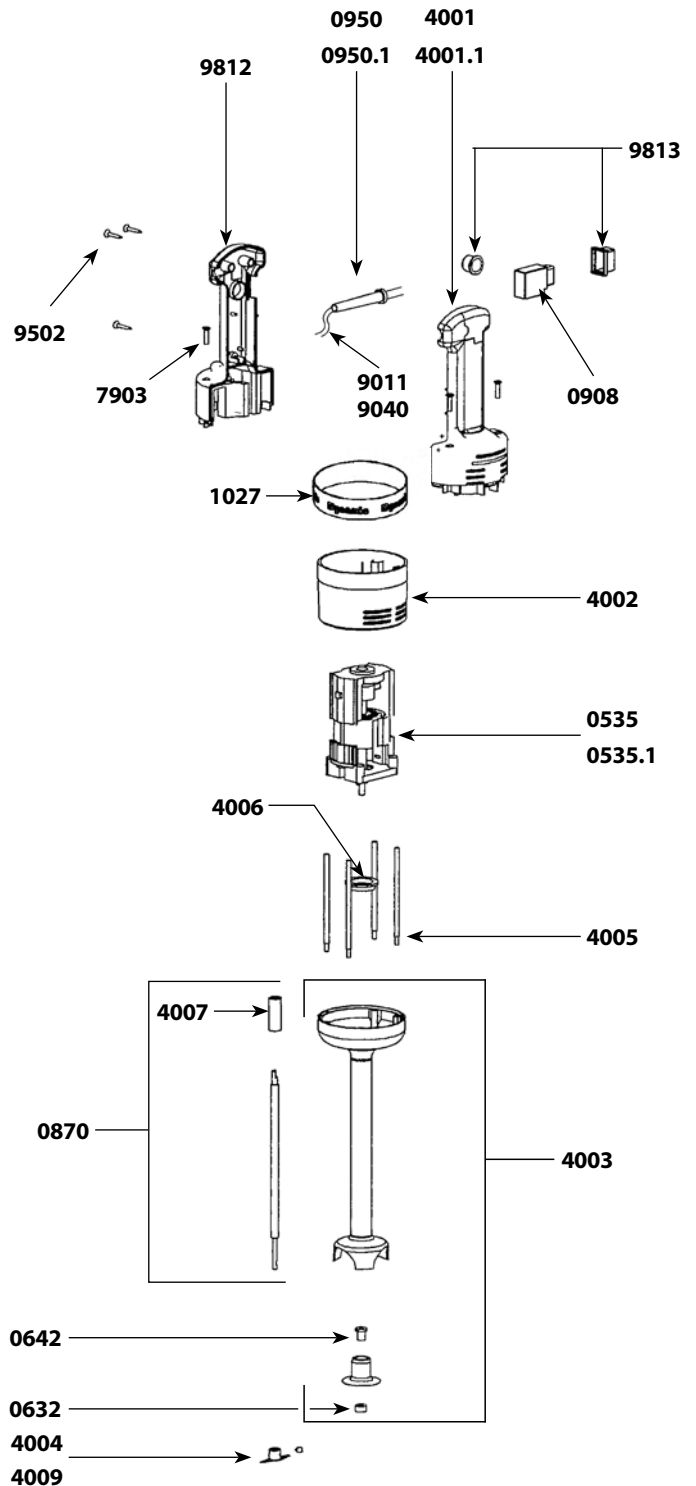

JUNIOR PLUS & JUNIOR COMBI

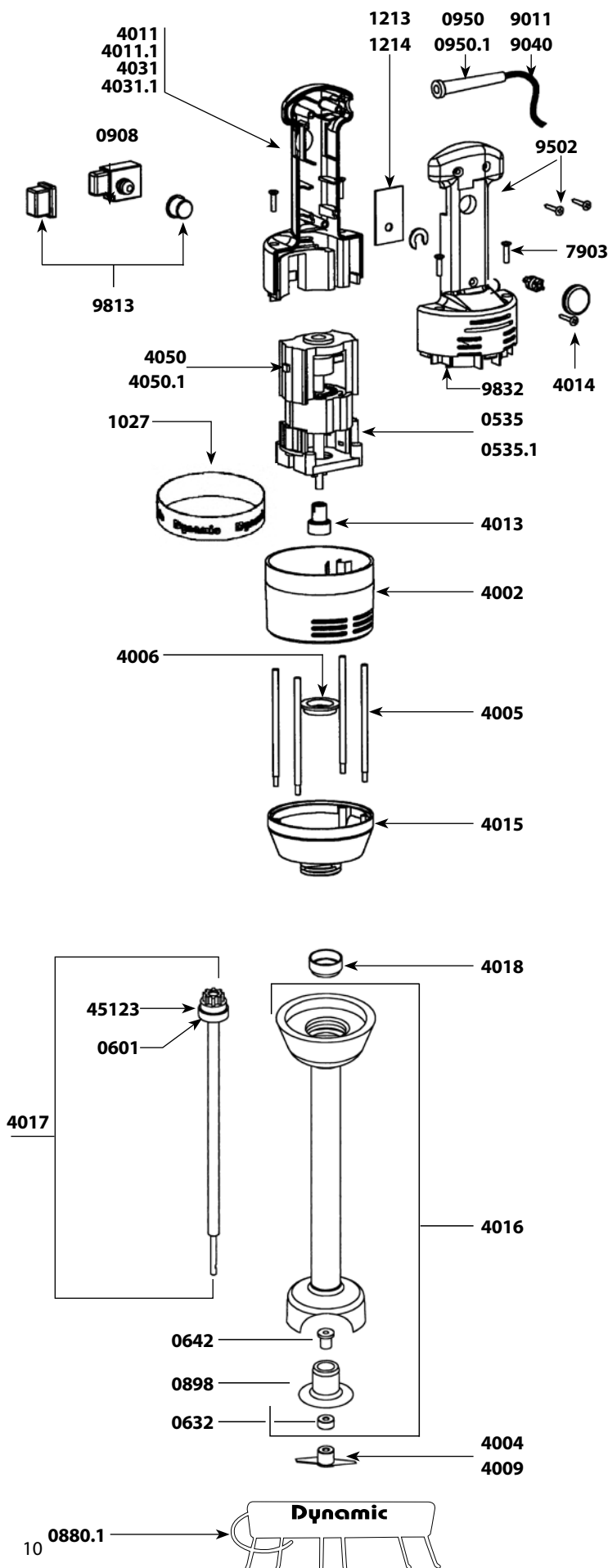

Power unit

Parts list

Code

Motor 230 V	0535
Motor 115 V	0535.1
Wall bracket	0880.1
Non-locking switch	0908
Strain relief 230V	0950
Strain relief 115V	0950.1
Dynamic label	1027
Id label (Junior Plus) 230V	1084
Id label (Junior Plus) 115V	1085
Id label (Junior Combi) 230V	1086
Id label (Junior Combi) 115V	1087
Speed variator 230V	1213
Speed variator 115V	1214
Upper motor housing	4002
Spacer rods (4)	4005
Ball bearing sleeve	4006
Complete handle w/ power cord 230V	4010
Complete handle w/ power cord 115V	4010.1
Lower half handle w/ Junior Plus label 230V	4011
Lower half handle w/ Junior Plus label 115V	4011.1
Filtering capacitor	4012
Coupling	4013
Speed variator knob	4014
Lower aluminium motor housing	4015
Complete handle w/ power cord 230V	4030
Complete handle w/ power cord 115V	4030.1
Lower half handle w/ Junior Combi label 230V	4031
Lower half handle w/ Junior Combi label 115V	4031.1
Motor brushes (2) 230 V	4050
Motor brushes (2) 115 V	4050.1
Spacer screws (4)	7903
Power cord 230 V	9011
Power cord 115 V	9040
Handle screws (3)	9502
Switch protector	9813
Upper half handle Junior Plus & Junior Combi	9832

Complete foot assembly

Parts list

Code

Ball bearing	0601
Waterproof seal	0632
Bushing	0642
Bearing only	0898
Cutter blade	4004
Emulsifying blade	4009
Foot assembly	4016
Kit w/shaft and coupling hub	4017
Ball bearing sleeve	4018
Coupling hub	45123

Whisk tool

Parts list

Code

Ball bearing	0601
Pins 3 x 10	0638
Pins 3 x 20	0744
Open head locking washer (unit)	0766
Entry gear	0837A
Lower motor whisk housing	4019
Equipped upper shaft (complete)	4020
Plate w/ seals and screws	4021
Holder assembly screws (4)	4022
Reduction gear assembly	4025
Middle gear & shaft	9420
Equipped output axle w/ 2 gears+pins	9421
Holder assembly w/ 3 self lubricating rings	9422
Whisk tool (2)	9424
Coupling hub	45123
Upper driving shaft	089947

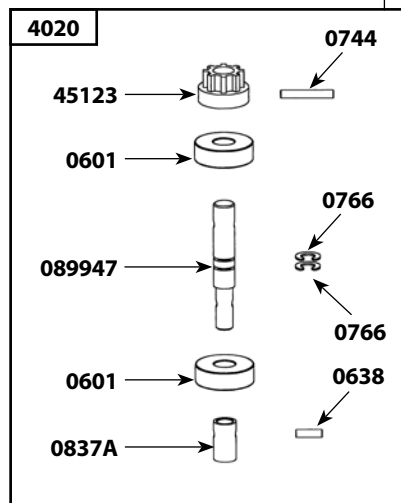
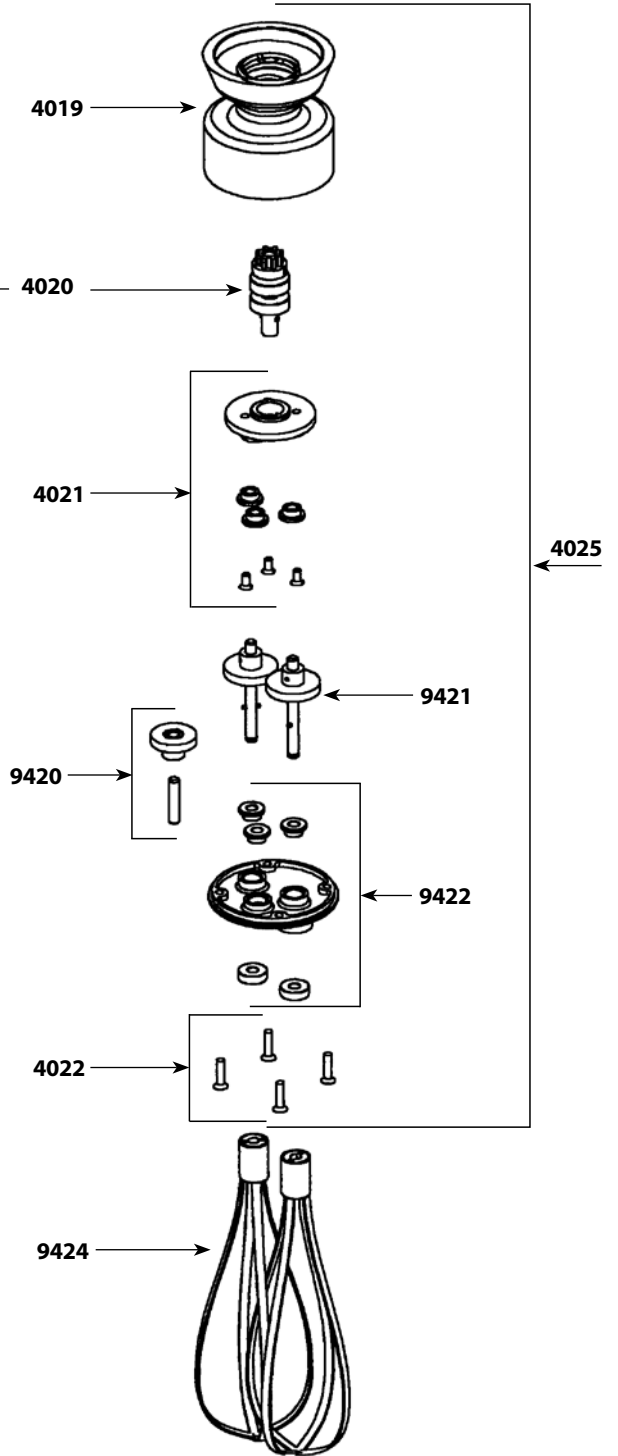

JUNIOR COMBI ACCESSORIES

Junior cutter

Parts list

Code

Base	1178
Equipped cover	2880.J
Blade	2881.J
Bowl	2882

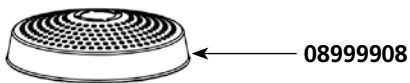
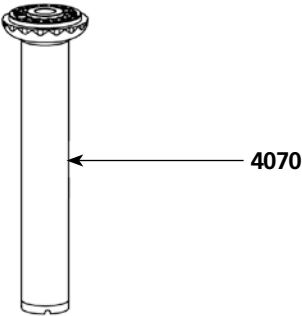
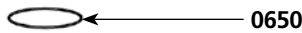
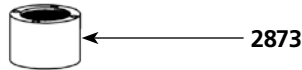
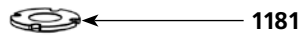
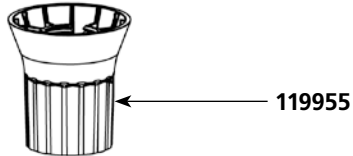
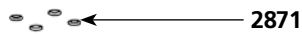
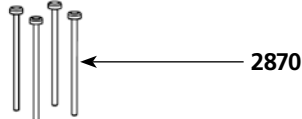
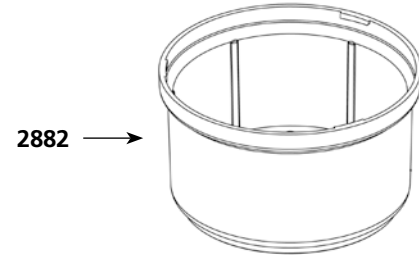
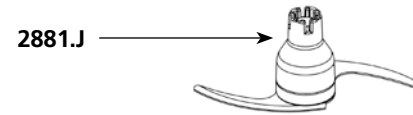
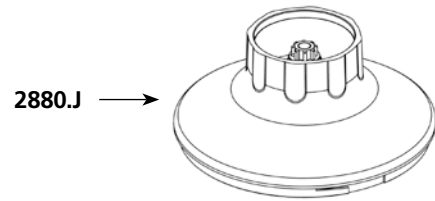

Junior Potato Ricer

Parts list

Code

Potato grid Junior	08999908
Potato blade Junior	08999909
O. ring	0650
Secured washer	1181
Grid holder	1195
Compression washer	1196
Ricer inferior carter Junior	119955
Handle screws (x 4)	2870
O. ring (x 4)	2871
Interior geared crown	2873
Equipped spacer for potato ricer Junior	4070
Equipped output shaft Junior	4071
Nut holder + nut Junior	4072
Equipped upper shaft Junior	4073

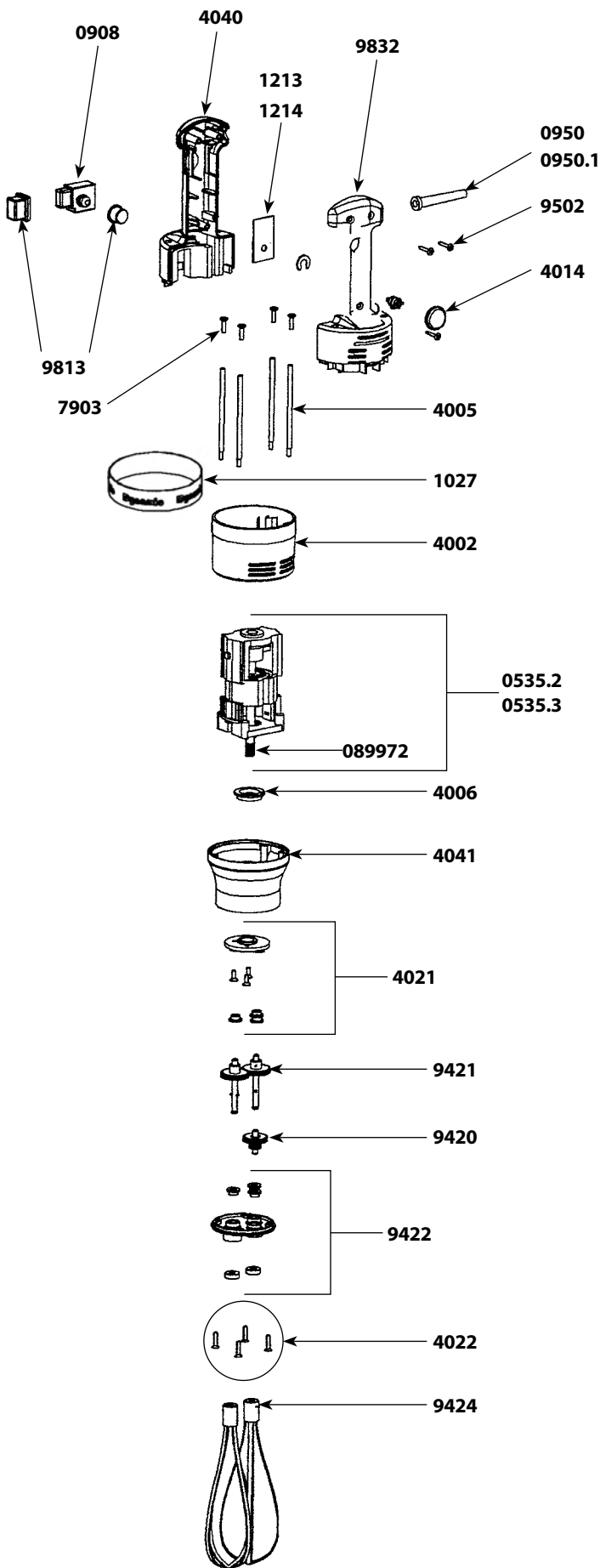

Parts list

Code

Motor 230 V + Gear	0535.2
Motor 115 V + Gear	0535.3
Pin 3x14	0745
Non-locking switch	0908
Strain relief 230V	0950
Strain relief 115 V	0950.1
Dynamic label	1027
Speed variator 230 V	1213
Speed variator 115 V	1214
Upper motor housing	4002
Spacer rods (4)	4005
Ball bearing sleeve	4006
Filtering capacitor	4012
Speed variator knob	4014
Plate w/ seals and screws	4021
Holder assembly screws (4)	4022
Lower half handle w/ Junior Whisk label 230 V	4040
Lower half handle w/ Junior Whisk label 115 V	4040.1
Lower aluminium motor housing	4041
Complete handle Junior Whisk 230 V	4042
Complete handle Junior Whisk 115 V	4042.1
Motor brushes (2) 230 V	4050
Motor brushes (2) 115 V	4050.1
Spacer screws (4)	7903
Power cord 230 V	9011
Power cord 115 V	9040
Middle gear & axle	9420
Equipped output axle w/ 2 gears+pins	9421
Holder assembly w/ seals & washer	9422
Whisk tool (2)	9424
Handle screws (3)	9502
Switch protector	9813
Upper half handle	9832
Label w/ serial number 230 V	1099.10
Label w/ serial number 115 V	1099.11
Wall bracket	089959
Gear + Pin	089972

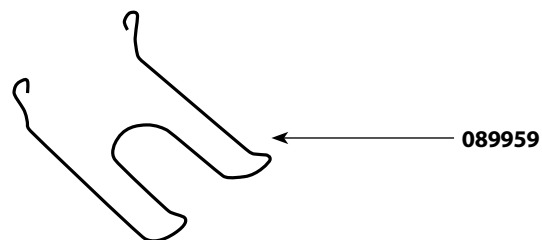

Parts list	Code
Pin for gear	0638
Enter gear w/ pin	0837
Non-locking switch	0908
Capacitor	0909
Strain relief 230 V	0950
Strain relief 115 V	0950.1
Dynamic label	1027
ID label 230 V	1059
ID label 115 V	1060
Speed variator 230 V	1213
Speed variator 115 V	1214
Spacer screws (4)	8317
Whisk connection box w/3 rings	9418
Middle gear & axle	9420
Output axle	9421
Holder assembly w/ 3 self lubricating rings	9422
Whisk tools (2)	9424
Power cord 230 V	9501
Power cord 115 V	9501.1
Handle screws (3)	9502
Upper half handle	9504
Spacer rods	9506
Half handle label side 230 V	9801
Half handle label side 115 V	9801.1
Complete handle 230 V (w/variator, power cord, switch and strain relief)	9802
Complete handle 115 V (w/variator, power cord, switch and strain relief)	9802.1
Motor holder	9803
Motor support w/4 screws 230 V	9804
Motor support w/4 screws 115 V	9804.1
Variator knob	9806

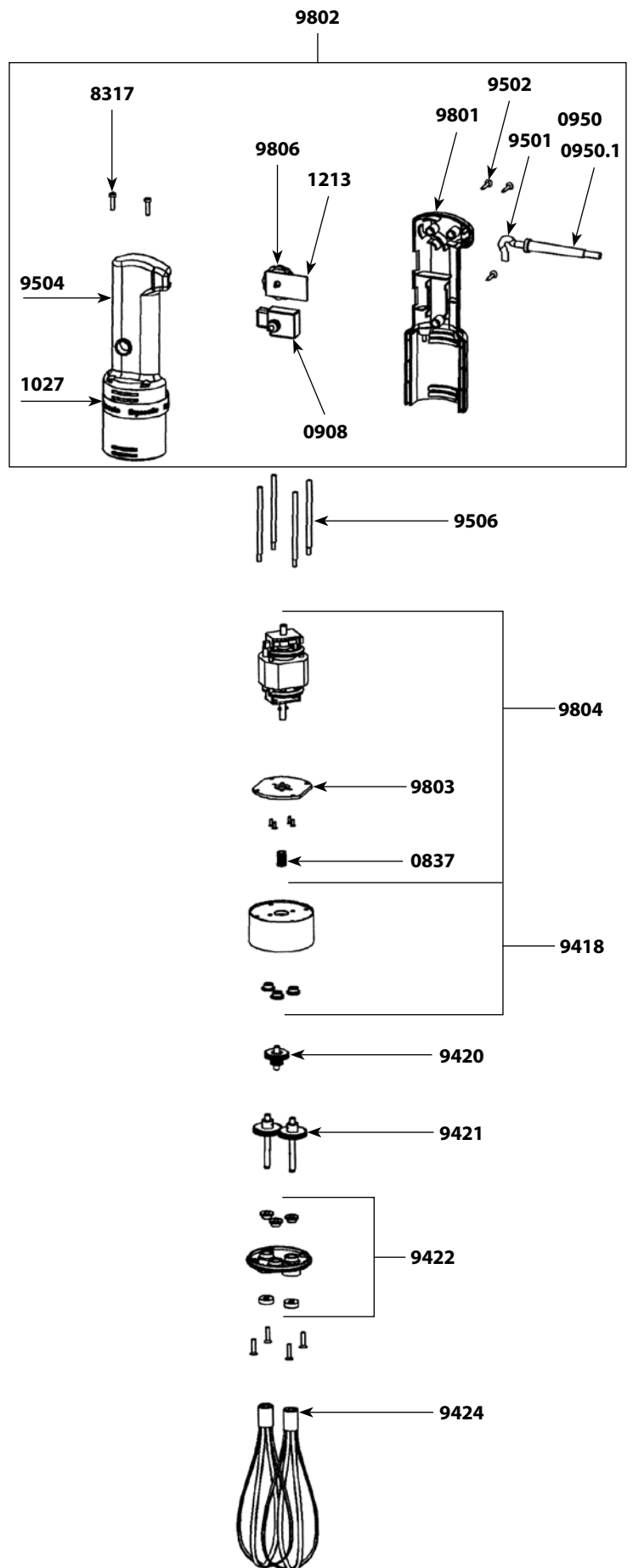

MXP 94 MINI CORDLESS MIXER

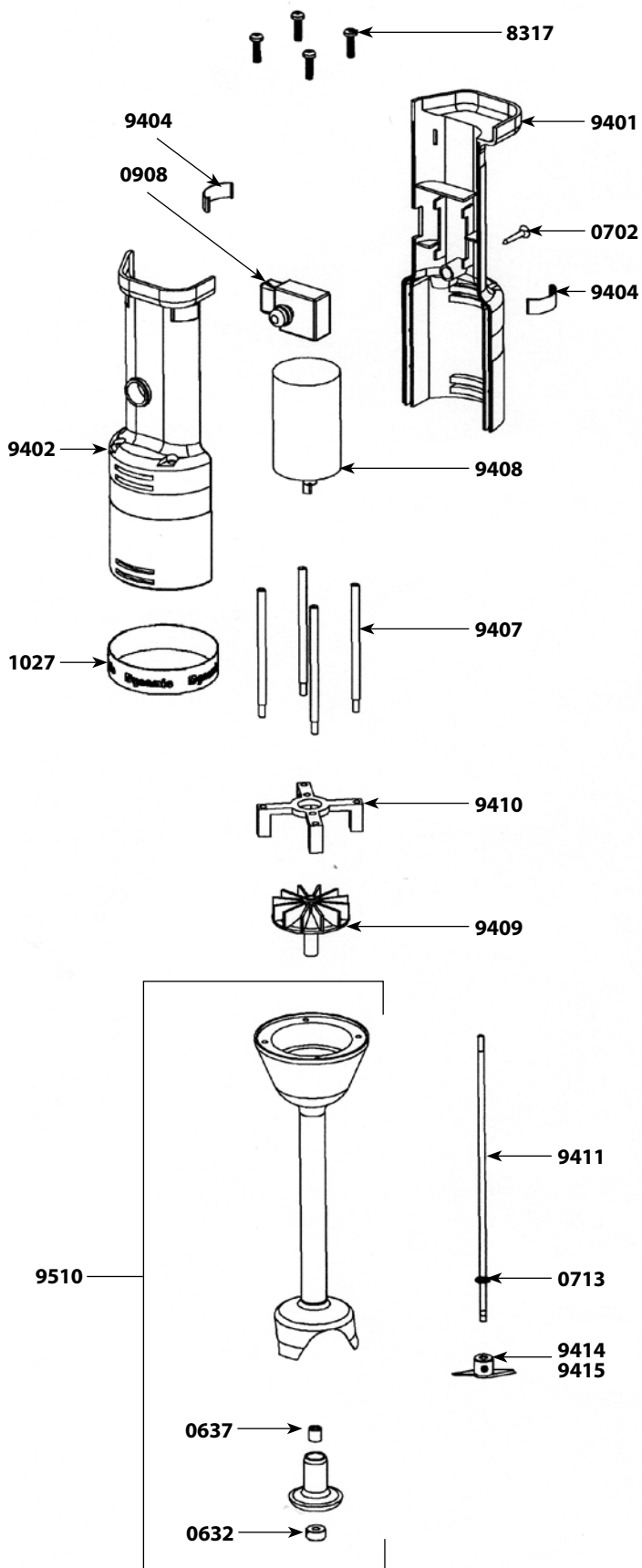

Parts list

Code

Parts list	Code
Waterproof seal	0632
Self-lubricating ring	0637
Handle screw (1)	0702
Locking washer	0713
Non-locking switch	0908
Dynamic label	1027
Spacer screws (4)	8317
Half handle (label side)	9401
Upper half handle	9402
Clips (2)	9404
Spacer rods (4)	9407
Motor	9408
Fan (coupling)	9409
Motor holder + screws	9410
Main shaft + locking washer	9411
Emulsifying blade	9414
Cutter blade w/screw	9415
Complete handle	9430
Foot assembly w/ bearing (exc. shaft + blade)	9510

Charger and battery

See machine catalog



FTP 94 MINI CORDLESS WHISK

Parts list	Code
Handle screw (1)	0702
Non-locking switch	0908
Dynamic label	1027
Holder assembly screws	4022
Spacer screws (4)	8317
Lower half handle (label side)	9401.1
Upper half handle	9402
Clips (2)	9404
Spacer rods (4)	9416
Motor & gear	9417
Whisk connection box w/3 rings	9418
Middle gear & axle	9420
Equipped output shaft w/2 gears + 2 pins	9421
Holder assembly w/ seals & washer+D331	9422
Whisks (2)	9424
Complete handle	9431

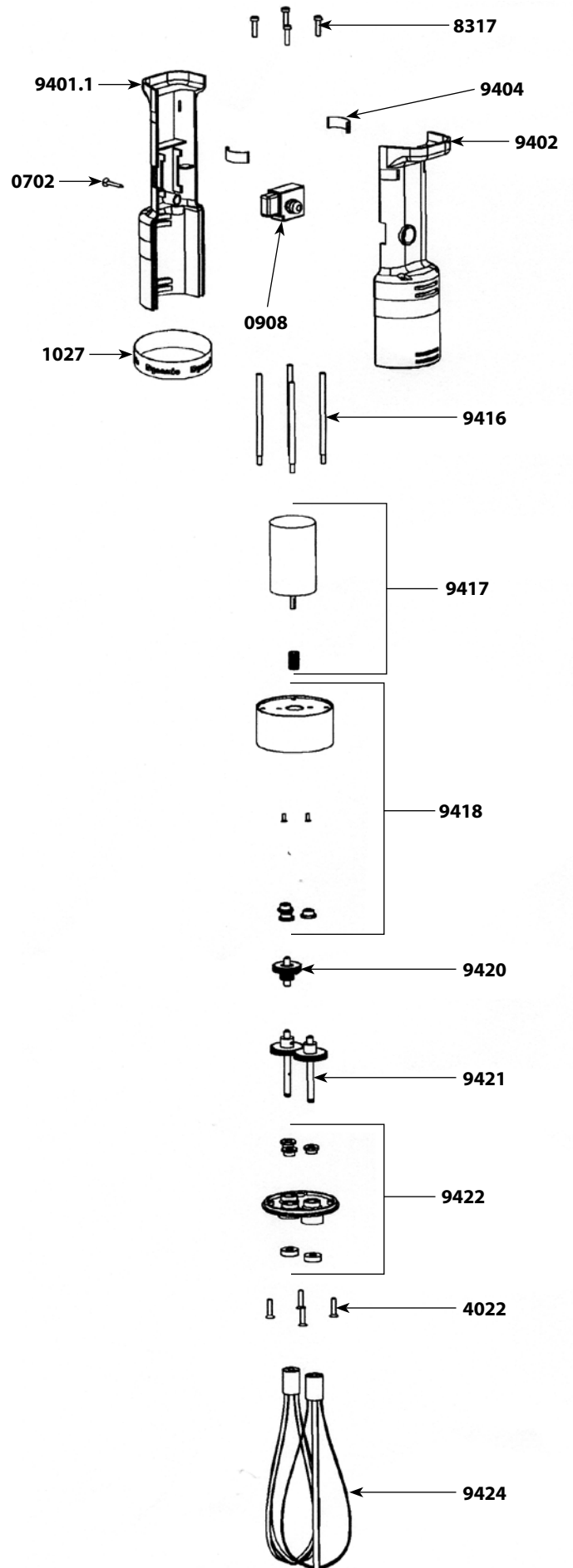

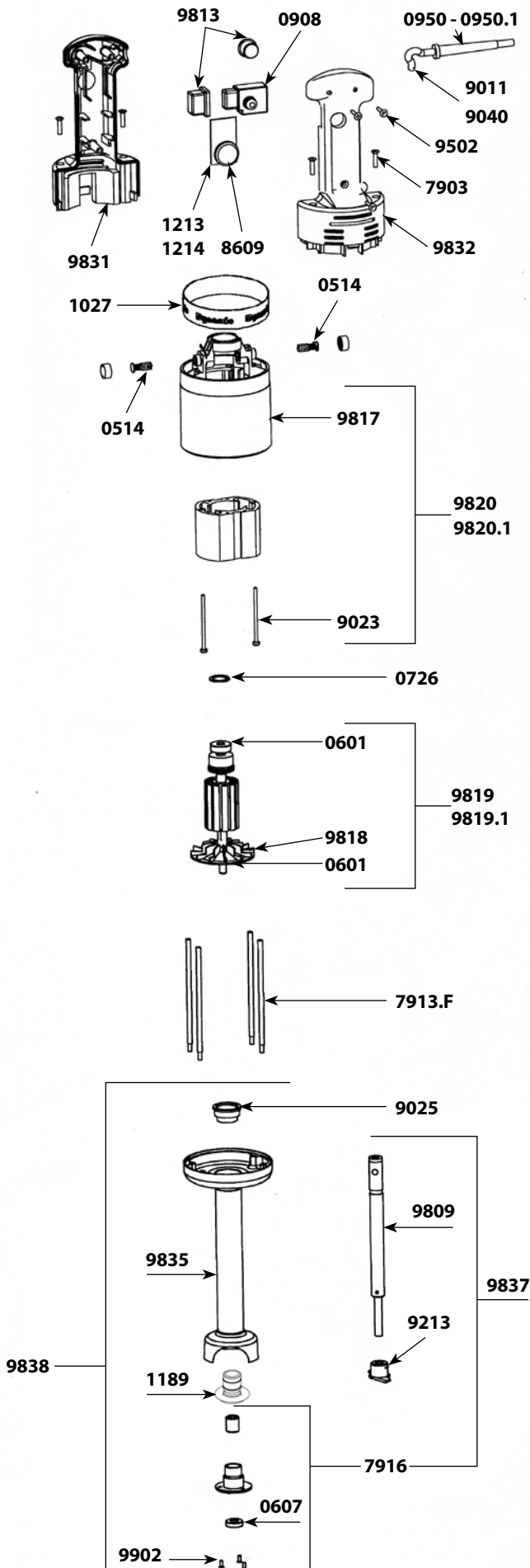

Parts list	Code
Motor brushes (2)	0514
Ball bearing	0601
Waterproof seal	0607
Squeezing washer	0726
Non-locking switch	0908
Capacitor	0909
Strain relief 230V	0950
Strain relief 115V	0950.1
Warning label	1017
Dynamic label	1027
Label w/ serial number 230V	1065
Label w/ serial number 115V	1066
Bearing holder + ring	1189
Variable speed control board 230V	1213
Variable speed control board 115V	1214
Spacer screws (4)	7903
Spacer rods (4)	7913.F
Lower bearing assembly	7916
Variable speed control button	8609
Power cord (2 cords) 230V	9011
Stator screws (2)	9023
Self-lubricating ring	9025
Power cord 115V	9040
Cutter blade w/screws	9213
Handle screws (3)	9502
Shaft	9809
Switch protector	9813
Upper motor casing (w/carbon brushes holder)	9817
Fan	9818
Rotor 230V	9819
Rotor 115V	9819.1
Stator 230V (w/carter. carbon brushes holder)	9820
Stator 115V (w/carter. carbon brushes holder)	9820.1
Complete handle w/ slot for speed control knob 230V	9830
Complete handle w/ slot for speed control knob 115V	9830.1
Lower half handle (label side) 230V	9831
Upper half handle (label side) 115V	9831.1
Upper half handle	9832
Foot assembly (tube + housing + bell + bearing)	9835
Motor & shaft housing	9837
Complete foot assembly	9838
Lower bearing screws (3)	9902

Parts list	Code
Motor brushes (2)	0514
Ball bearing	0601
Self-lubricating ring	0604
Waterproof seal	0607
O. ring	0611
Motor self-lubricating ring	0829
Hook	0860
Stainless steel bell	0833
Non-locking switch	0908
Capacitor	0909
Strain relief 230 V	0950
Strain relief 115 V	0950.1
Spacer rods (4)	7913M
Complete handle 230 V	8301
Complete handle 115 V	8301.1
Handle only w/screws	8302
Power cord 230 V	8303
Power cord 115 V	8303.2

Parts list	Code
Complete Motor 230 V	8304
Complete Motor 115 V	8304.1
Rotor 230 V	8304.12
Rotor 115 V	8304.13
Stator 230 V	8304.22
Stator 115 V	8304.23
Shaft	8309
S.S. lower ball bearing assembly	8310
Motor & shaft housing	8311
Cutter blade w/screw	8313
Upper motor casing (w/carbon brushes holder)	8315
Spacer screws	8317
Lower motor casing	8318
Handle cover + screws	8319
Deflector	8320
Ground wire	8321
Screws w/ ground washer (2)	8322
Fan	8323

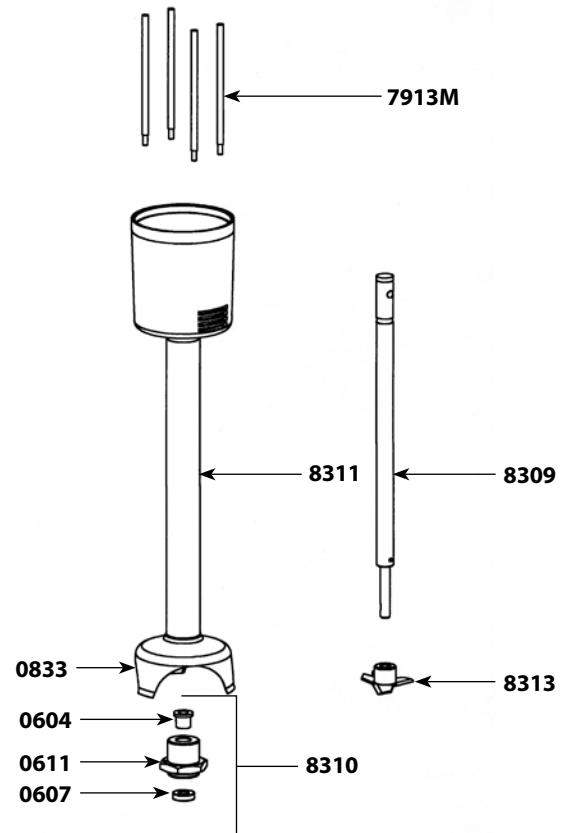
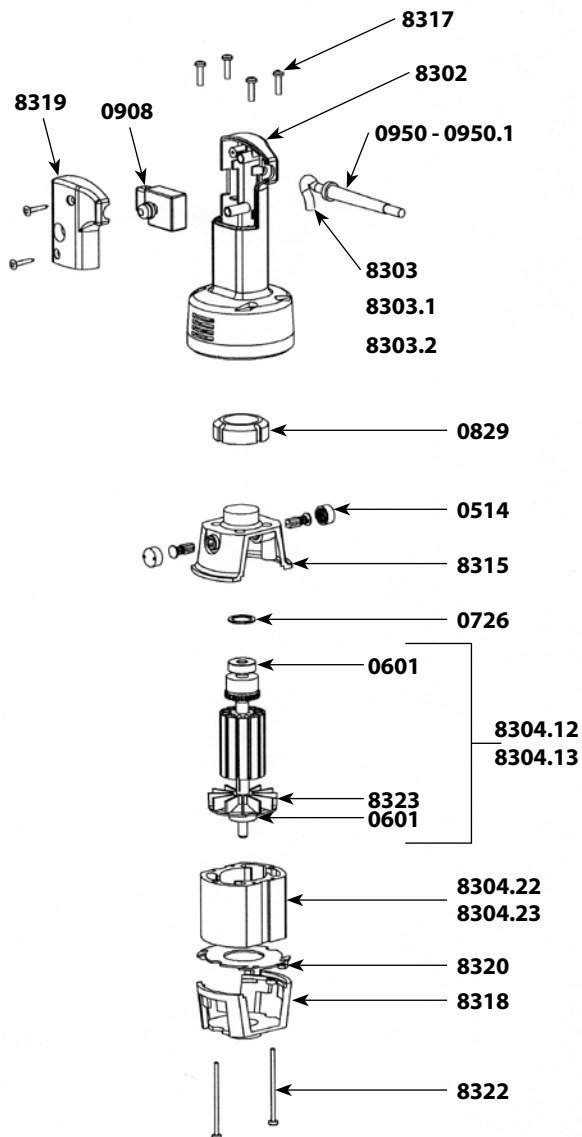

9810 - 9810.1

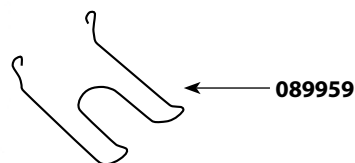
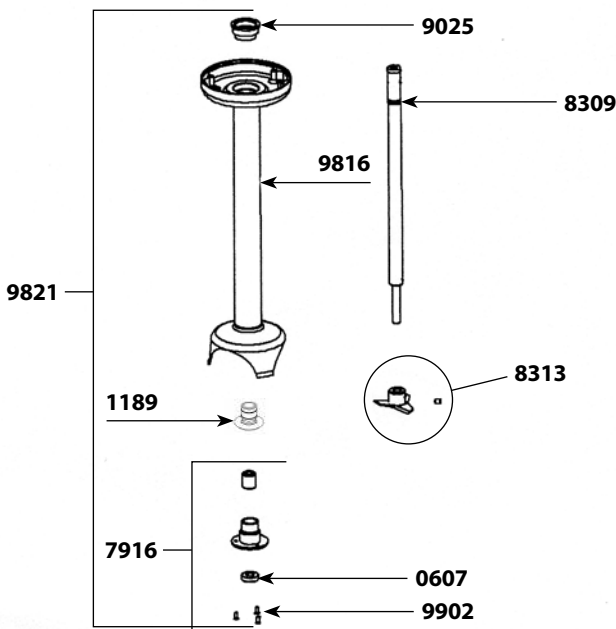
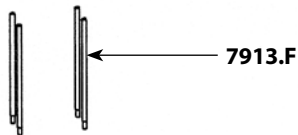
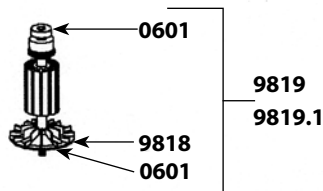
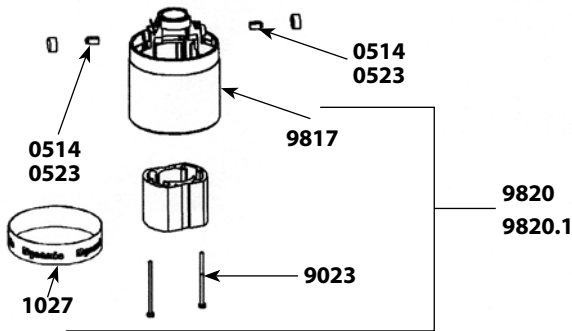
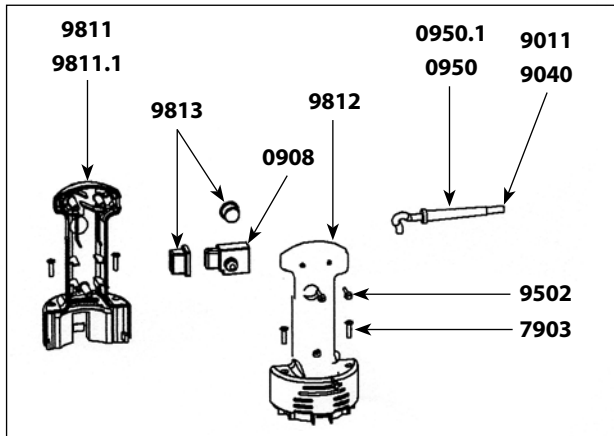

Parts list

Code

Motor brushes (2)	0514
Motor Brushes (2) after serial # 130803	0523
Ball bearing	0601
Waterproof seal	0607
Squeezing washer	0726
Wall bracket	089959
Non-locking switch	0908
Strain relief 230V	0950
Strain relief 115V	0950.1
Capacitor	0972.1
Warning label	1017
Dynamic label	1027
Label w/ serial number 230V	1063
Label w/ serial number 115V	1064
Lower bearing assembly support	1189
Speed variator (option) (230V)	1213
Speed variator (option) (115V)	1214
Spacer screws (4)	7903
Spacer rods (4)	7913.F
Lower ball bearing assembly	7916
Shaft	8309
Cutter blade w/screw	8313
Power cord 230V	9011
Stator screws (2)	9023
Ball bearing sleeve	9025
Power cord 115V	9040
Handle screws (3)	9502
Complete handle 230V	9810
Complete handle 115V	9810.1
Lower half handle w/ label 230V	9811
Lower half handle w/ label 115V	9811.1
Upper half handle	9812
Switch protector (2)	9813
Motor & shaft housing + palier + bearing	9816
Upper motor casing (w/carbon brushes holders)	9817
Fan	9818
Rotor 230V	9819
Rotor 115V	9819.1
Stator 230V (w/carter. carbon brushes holders)	9820
Stator 115V (w/carter. carbon brushes holders)	9820.1
Complete foot assembly	9821
Shaft. lower ball bearing & cutter assembly	9836
Lower bearing screws (3)	9902

MOTOR BLOCK PMDH / PMF 250

Parts list	Code
Motor brushes (2)	0514
Ball bearing	0601
Squeezing washer	0726
Wall bracket	0880
Non-locking switch	0908
Capacitor	0909
Strain relief 230 V	0950
Strain relief 115V	0950.1
Warning label	1017
Dynamic label	1027
Label w/ serial number 230 V	1071
Label w/ serial number 115 V	1072
Variable speed control board 230 V	1213
Variable speed control board 115 V	1214
Spacer screws (4)	7903
Spacer rods (4)	7913.F
Variable speed control knob	8609
Power cord 230 V	9011
Stator screws (2)	9023
Self-lubricating ring	9025
Coupler for armature	9028
Power cord 115 V	9040
Handle screws (3)	9502
Switch protector	9813
Upper motor casing	9817
Fan	9818
Rotor w/o coupling 230 V	9819
Rotor w/o coupling 115 V	9819.1
Stator 230 V w/carter. carbon brushes holders	9820
Stator 115 V w/carter. carbon brushes holders	9820.1
Upper half handle	9832
Complete handle 230 V	9840
Complete handle 115 V	9840.1
Lower half handle w/ label 230 V	9841
Lower half handle w/ label 115 V	9841.1
Aluminium carter	9842
BM 250 Motor block (see machine catalog)	AC005

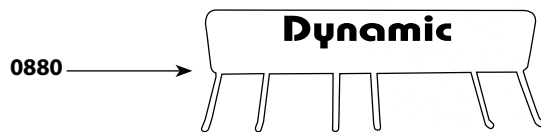
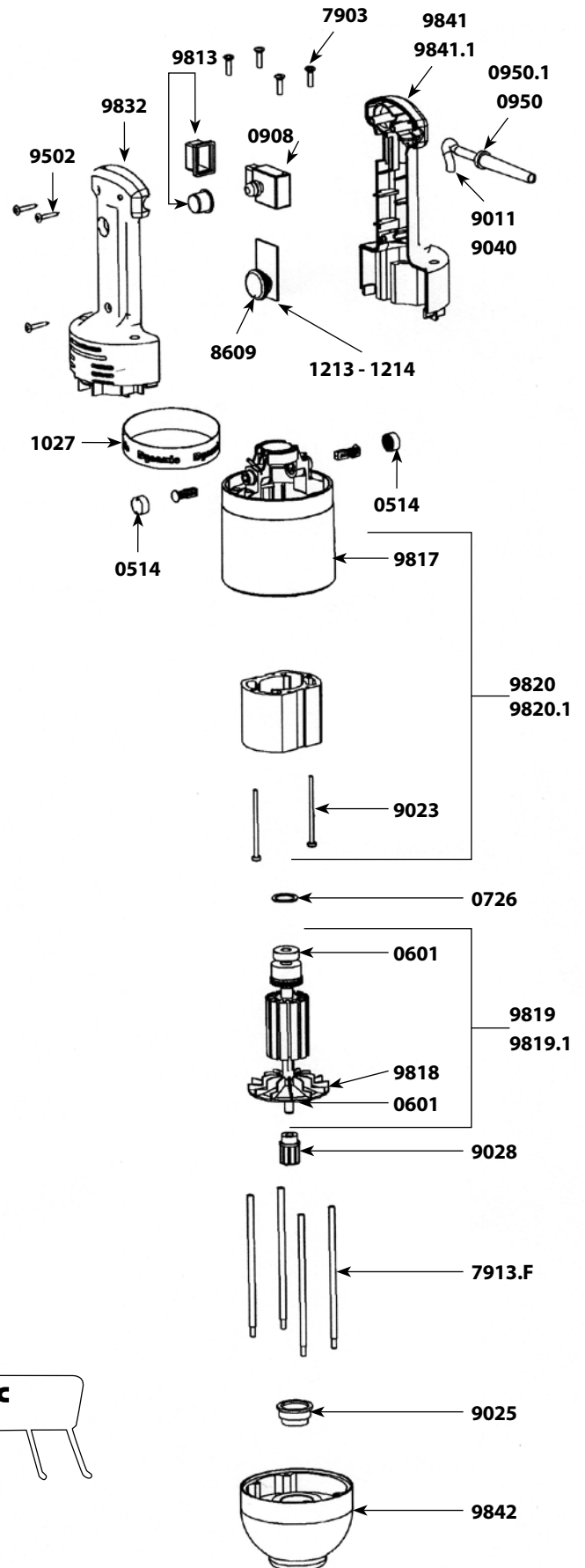

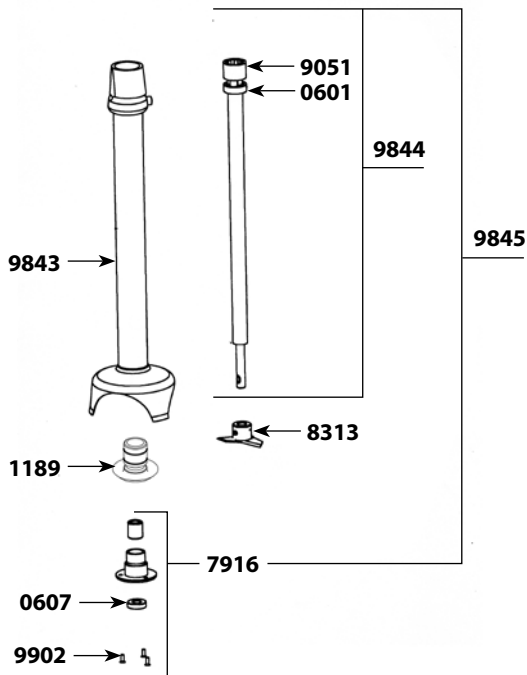

PMF - PMDH 250 foot

Parts list

Code

Ball bearing	0601
Waterproof seal	0607
Lower bearing assembly support	1189
Lower ball bearing assembly	7916
Cutter blade (w/screw)	8313
Coupling casing + pins	9051
Tube assembly + palier + bearing	9843
Shaft & coupling sleeve	9844
Shaft. lower bearing & cutter assembly	9845
Lower bearing screws (3)	9902
M 250 Complete Mixer tool (see machine catalog)	AC006

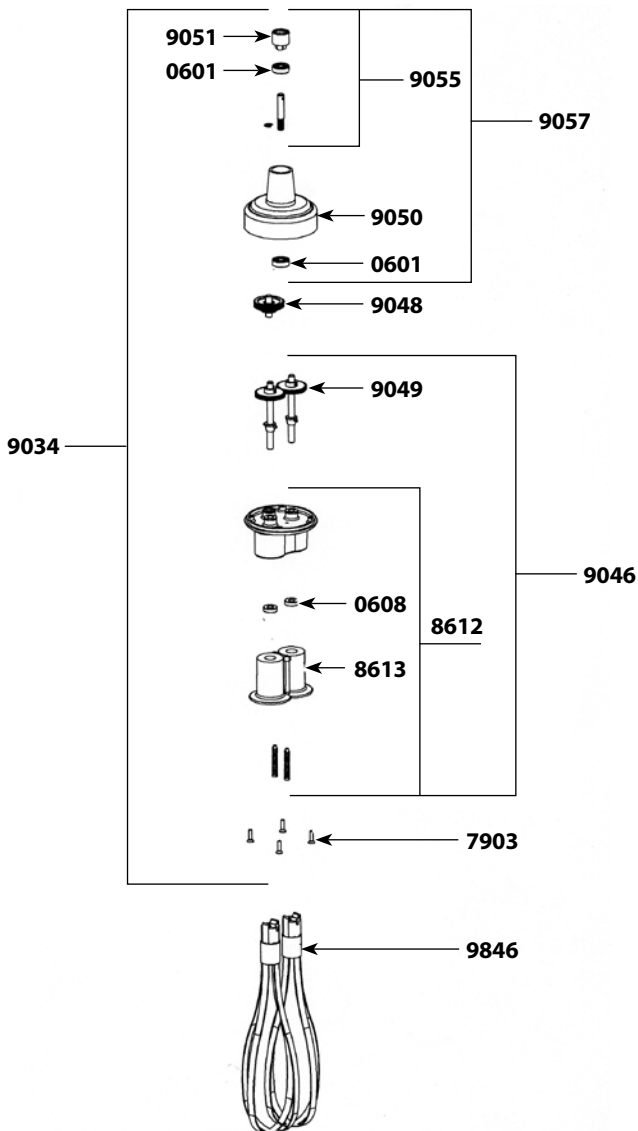

PMF 250 whisk tools

Parts list

Code

Ball bearing	0601
Waterproof seal for whisk	0608
Pin 3 X 20	0744
Pin 3 X 14	0745
Spacer screws (4)	7903
Holder + plastic ejector + seal	8612
Plastic ejectors (pair)	8613
Reduction gear assembly	9034
Lower casing w/o middle gear	9046
Central double gear & shaft	9048
Single gear (2) + pin	9049
Upper plastic casing	9050
Coupling casing + pin	9051
Equipped upper shaft	9055
Complete upper casing	9057
Whisks (2)	9846
F 250 Complete Whisk tool (see machine catalog)	AC007

Parts list	Code
Sleeve	0415
Motor brushes (2)	0504
Ball bearing	0601
Waterproof seal	0607
O. ring	0610
Squeezing washer	0726
Rocking switch	0903
Strain relief 230 V	0950
Strain relief 115 V	0950.1
Complete handle	7901
Spacer screws (4)	7903
ID plate 230 V	7904M
ID plate 115 V	7904M.1
Motor housing w/carbon brush holder	7905
Motor 230 V	7908
Motor 115 V	7908.1
Rotor with fan 115 V	7908.11
Rotor with fan 230 V	7908.12
Stator 115 V	7908.21
Stator 230 V	7908.22
Power cord 230 V	7911M
Power cord 115 V	7911M.1
Ball bearing sleeve	7912
Brace (4)	7913M
Foot assembly w/ lower bearing assembly	7914
Shaft & coupling sleeve	7915
Lower bearing assembly	7916
Cutter blade w/screw	7917
Capacitor	7931
Fan	7933
Shaft. lower bearing & cutter assembly	7934
Handle top w/screw	7938
Lower bearing screws (3)	7950
Lower bearing all stainless screws (3)	9902

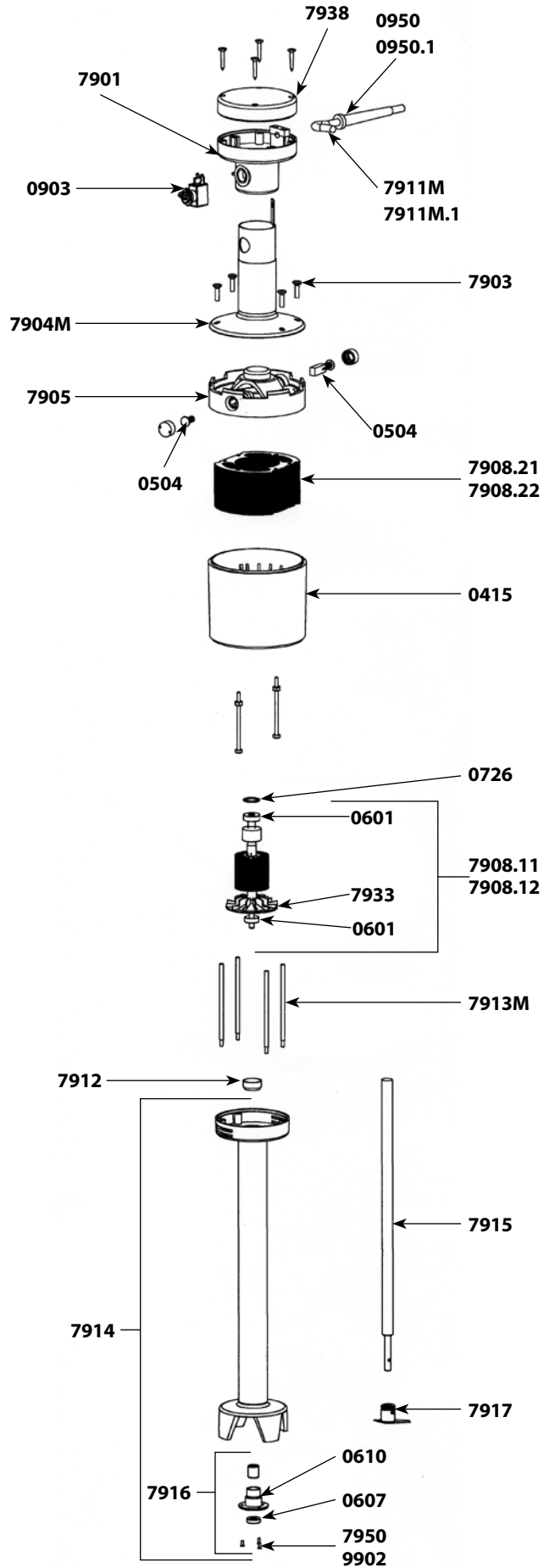

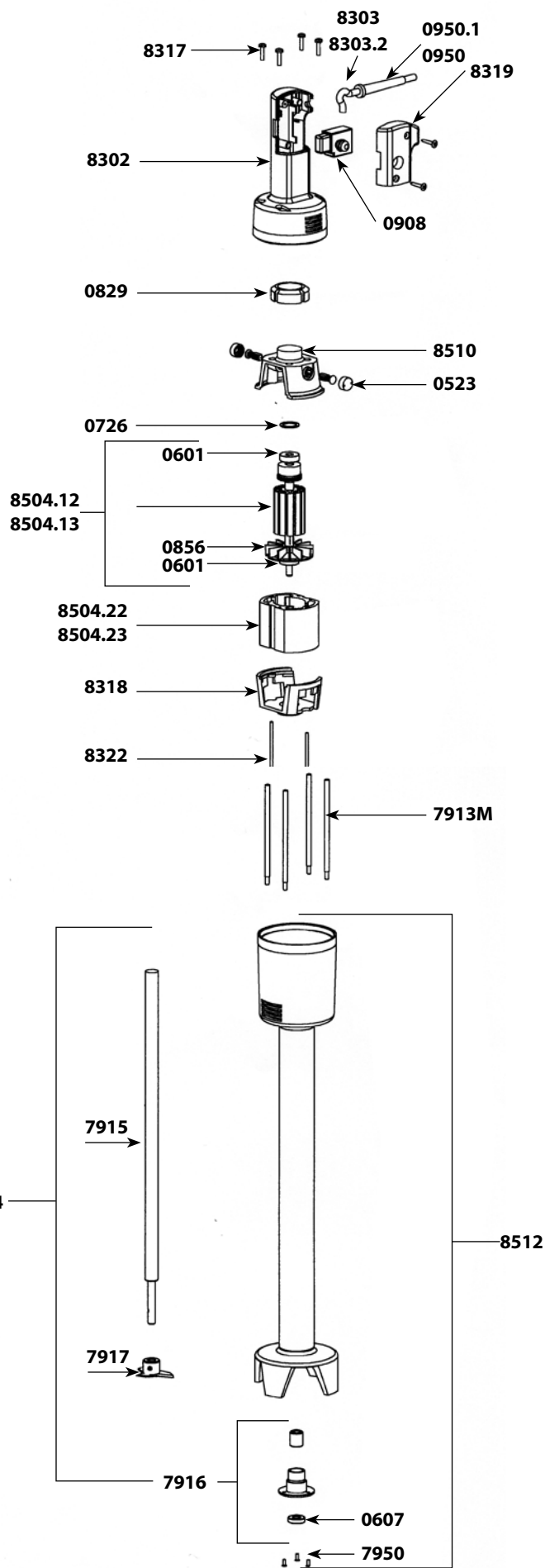

Parts list

Code

Motor brushes (2)	0523
Ball bearing	0601
Waterproof seal	0607
O. ring	0610
Squeezing washer	0726
Motor self-lubricating ring	0829
Fan	0856
Hook	0860
Non-locking switch	0908
Capacitor	0909
Strain relief 230 V	0950
Strain relief 115 V	0950.1
Brace (4)	7913M
Shaft	7915
Lower bearing assembly	7916
Cutter blade w/screw	7917
Shaft, lower bearing & cutter assembly	7934
Lower bearing screws (3)	7950
Complete handle 230 V	8301
Complete handle 115 V	8301.1
Handle only w/screws	8302
Power cord 230 V	8303
Power cord 115 V	8303.2
Spacer screws (4)	8317
Lower motor casing	8318
Cover for handle	8319
Ground wire	8321
Screws w/ ground washer	8322
Motor 230 V	8504
Motor 115 V	8504.1
Rotor 230 V	8504.12
Rotor 115 V	8504.13
Stator 230 V	8504.22
Stator 115 V	8504.23
Upper motor casing (w/carbon brushes holder)	8510
Foot assembly w/ lower ball bearing assembly	8512

Parts list	Code
Motor brushes (2)	0504
Ball bearing	0601
Waterproof seal	0607
Squeezing washer	0726
Lock button return spring	0767
Safety button return spring	0768
Wall bracket	0881
Long wall bracket	0881.L
Strain relief 230 V	0950
Strain relief 115 V	0950.1
Switch (230 V / 115 V)	0965
Capacitor (115V)	0972
Capacitor + filter (230V)	0972.1
Warning label	1017
Dynamic label	1027
Label w/ serial number 230 V	1028
Label w/ serial number 115 V	1029
Bering holder + seal	1186
Emulsifying blade	7910
Lower bearing assembly	7916
Cutter blade	7917
Fan	7933
Lower bearing screws (3)	7950
Spacer screws (4)	8317
Upper half handle (button side)	9002
Safety switch	9005
Locking switch	9007
Rotor 115 V	9008.11
Rotor 230 V	9008.12
Plug	9009
Control lever	9010
Power cord 230 V	9011
Handle screws (4)	9014
Motor housing brush holder	9015
Stator 230 V	9016
Motor field screws (2)	9023
Ball bearing sleeve	9025
Spacer rods (4)	9026
Stator 115 V	9038
Power cord 115 V	9040
Motor brush wires 230 V	9043
Complete handle w/ power cord 230 V	9100
Complete handle w/ power cord 115 V	9100.1
Half handle. label side (230V)	9101
Half handle. label side (115V)	9101.1
Speed control plug	9112
Complete foot assembly	9129
Foot assembly w/ bearing assembly	9130
Fitted shaft	9131
Carbon brush wires 115 V	9143
Shaft. lower bearing & cutter assembly	9164
Lower bearing screws (3)	9902

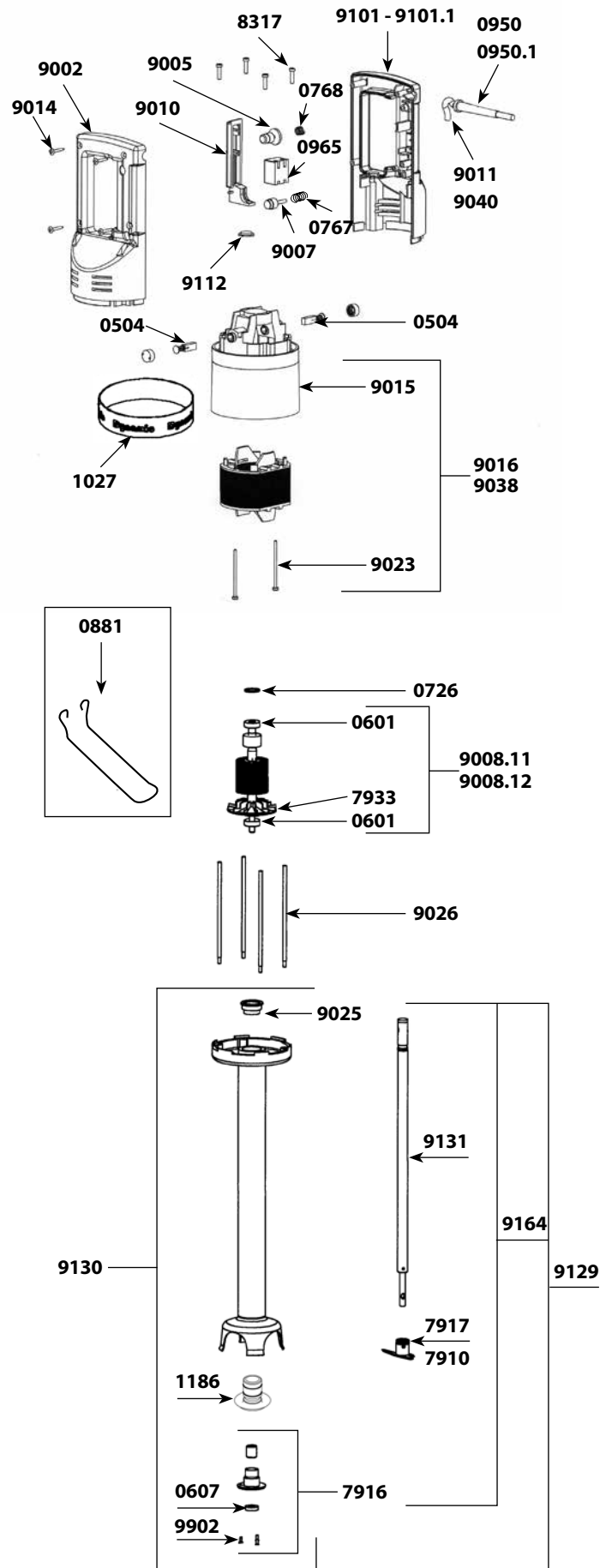

MDH 460 DETACHABLE

Motor

Parts list

Code

Motor brushes (2)	0504
Ball bearing	0601
Squeezing washer	0726
Lock button return spring	0767
Safety button return spring	0768
Strain relief 230 V	0950
Strain relief 115 V	0950.1
Switch	0965
Capacitor	0972
Capacitor + filter	0972.1
Warning label	1017
Dynamic label	1027
ID label 230 V	1054
ID label 115 V	1055
Fan	7933
Spacer screws (4)	8317
Half handle (button side)	9002
Rubber button cap	9005
Lock button	9007
Rotor 115 V	9008.11
Rotor 230 V	9008.12
Plug	9009
Control lever	9010
Power cord 230 V	9011
Handle screws (4)	9014
Motor housing brush holder	9015
Stator 230 V	9016
Motor field screws (2)	9023
Lower aluminum housing	9024
Ball bearing sleeve	9025
Spacer rods (4)	9026
Coupler for armature	9028
Stator 115 V	9038
Power cord 115 V	9040
Ground wire 230 V	9043
Speed control plug	9112
Ground wire 115 V	9143
Complete handle 230 V	9900
Complete handle 115 V	9900.1
230 V Half handle (label side)	9903
115 V Half handle (label side)	9903.1

FOR FOOT ATTACHMENT, REFERENCE PAGE 34

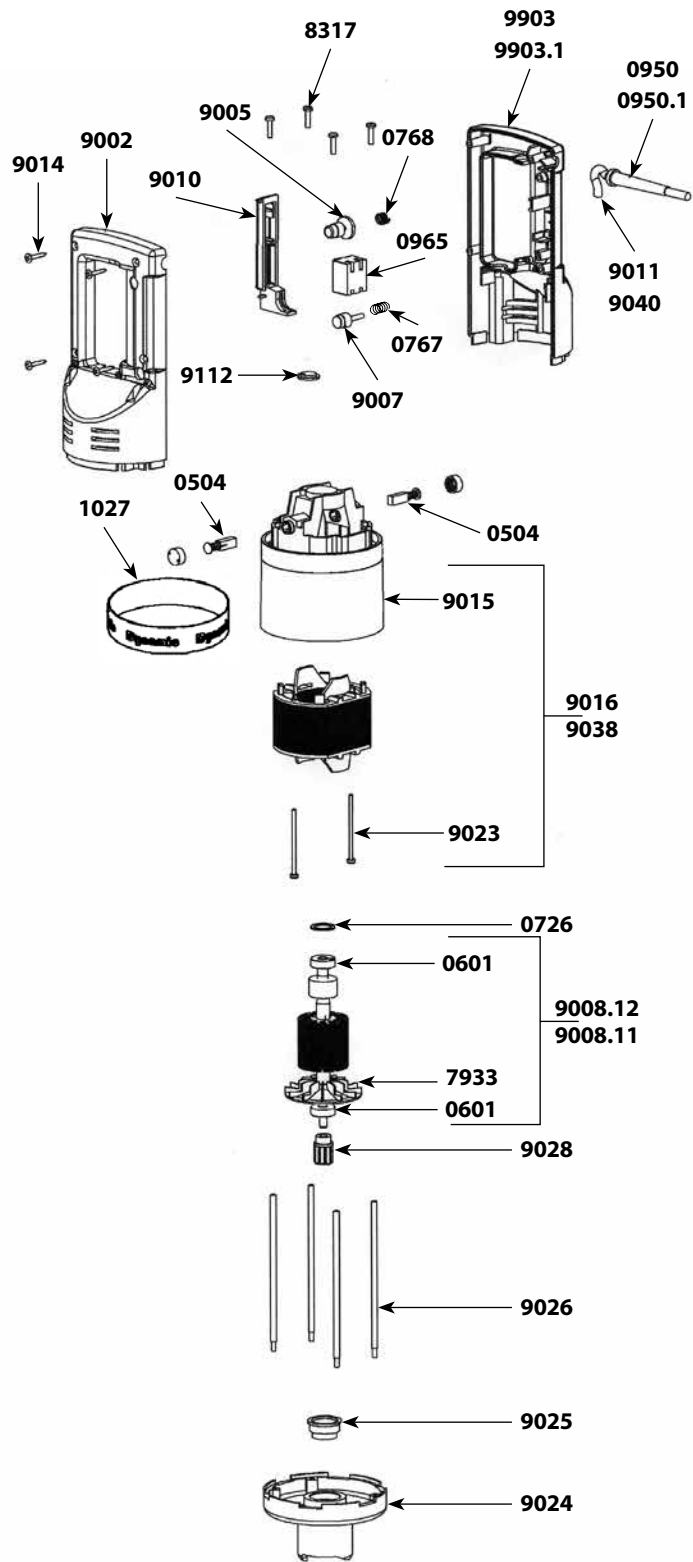

Motor

Parts list	Code
Motor brushes (2)	0504
Ball bearing	0601
Squeezing washer	0726
Safety button return spring	0768
Strain relief 230 V	0950
Strain relief 115 V	0950.1
C.E.M. Filter	0999.20
Warning label	1017
Dynamic label	1021
ID label 230 V	1075
ID label 115 V	1076
Micro switch	1237
Power on indicator light 230 V	1241
Power on indicator light 115 V	1241.1
Control lever	2001
Control lever protector	2002
Circuit board 230 V (4 switches + capacitor)	2003
Circuit board 115 V (4 switches + capacitor)	2003.1
Half handle (no button)	2004
Half handle (button side)	2005
Motor housing brush holder	2006
Speed control plug	2008
Complete handle 230 V	2010
Complete handle 115 V	2010.1
Stator 230 V (0504 not included)	2011
Stator 115 V (0504 not included)	2011.1
Power cord 230 V > 2002	2012
Power cord 115 V > 2002	2012.1
Lower aluminum housing	2020
Speed variator knob	2021
Complete handle 230 V with variator (from N°040132)	2022
Complete handle 115 V with variator (from N°040132)	2022.1
Speed variator 230 V	2023
Speed Variator 115 V	2023.1
Spacer screws (4)	7903
Fan	7933
Rotor 115 V	9008.11
Rotor 230 V	9008.12
Power cord 230 V < 2002	9011
Handle screws (4)	9014
Motor field screws (2)	9023
Motor ball bearing sleeve	9025
Spacer rods (4)	9026
Coupler for armature	9028
Power cord 115 V < 2002	9040
Carbons brush wires 230 V	9043
Power cord (Australian) < 2002	9066
Carbons brush wires 115 V	9143
Rubber button cap	45710

FOR FOOT ATTACHMENT, REFERENCE PAGE 34

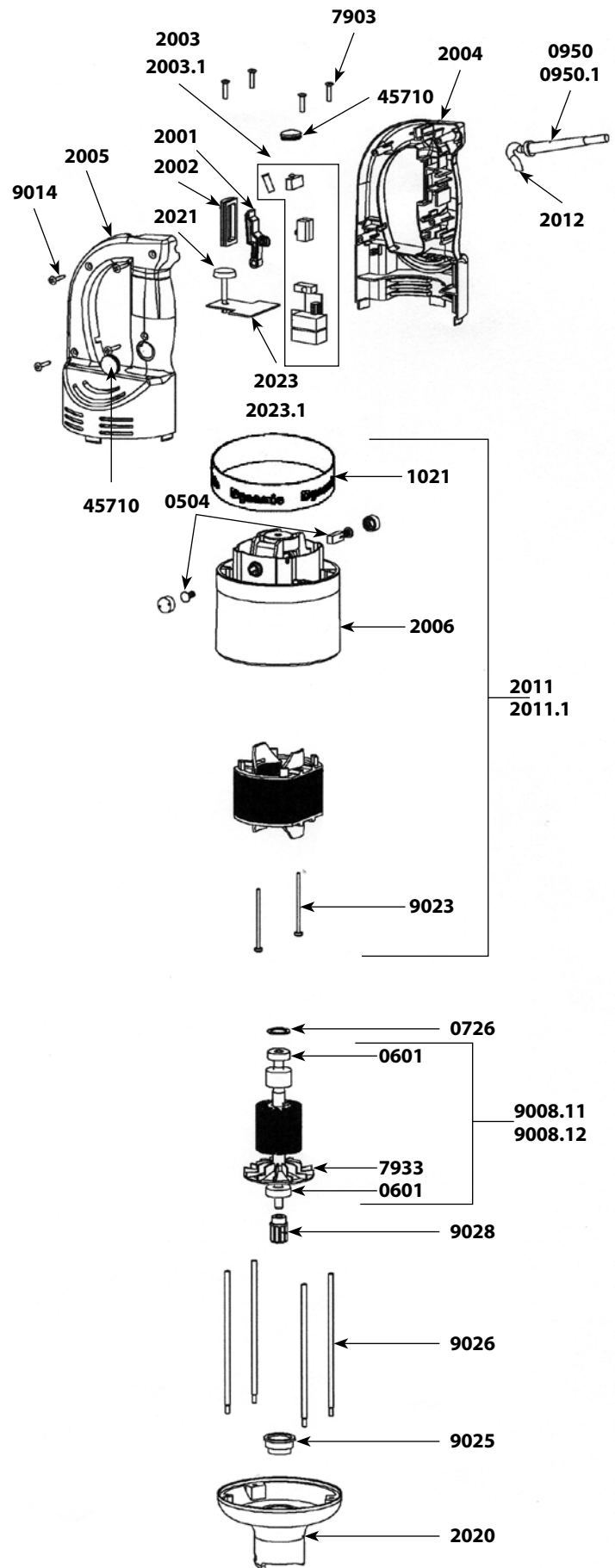

Motor

Parts list Code

Motor brushes (2)	0504
Ball bearing	0601
Squeezing washer	0726
Safety button return spring	0768
Strain relief 230 V	0950
Strain relief 115 V	0950.1
C.E.M. Filter	0999.20
Warning label	1017
Dynamic label	1021
ID label 230 V	1075
ID label 115 V	1076
Micro switch	1237
Power on indicator light 230 V	1241
Power on indicator light 115 V	1241.1
Control lever	2001
Control lever protector	2002
Circuit board 230 V (4 switches + capacitor)	2003
Circuit board 115 V (4 switches + capacitor)	2003.1
Half handle (no button)	2004
Half handle (button side)	2005
Motor housing brush holder	2006
Speed control plug	2008
Complete handle 230 V	2010
Complete handle 115 V	2010.1
Stator 230 V (0504 not included)	2011
Stator 115 V (0504 not included)	2011.1
Power cord 230 V > 2002	2012
Power cord 115 V > 2002	2012.1
Lower aluminum housing	2020
Speed variator knob	2021
Complete handle 230 V with variator (from N°040132)	2022
Complete handle 115 V with variator (from N°040132)	2022.1
Speed variator 230 V	2023
Speed Variator 115 V	2023.1
Spacer screws (4)	7903
Fan	7933
Rotor 115 V	9008.11
Rotor 230 V	9008.12
Power cord 230 V < 2002	9011
Handle screws (4)	9014
Motor field screws (2)	9023
Motor ball bearing sleeve	9025
Spacer rods (4)	9026
Coupler for armature	9028
Power cord 115 V < 2002	9040
Carbons brush wires 230 V	9043
Power cord (Australian) < 2002	9066
Carbons brush wires 115 V	9143
Rubber button cap	45710

FOR FOOT ATTACHMENT, REFERENCE PAGE 34

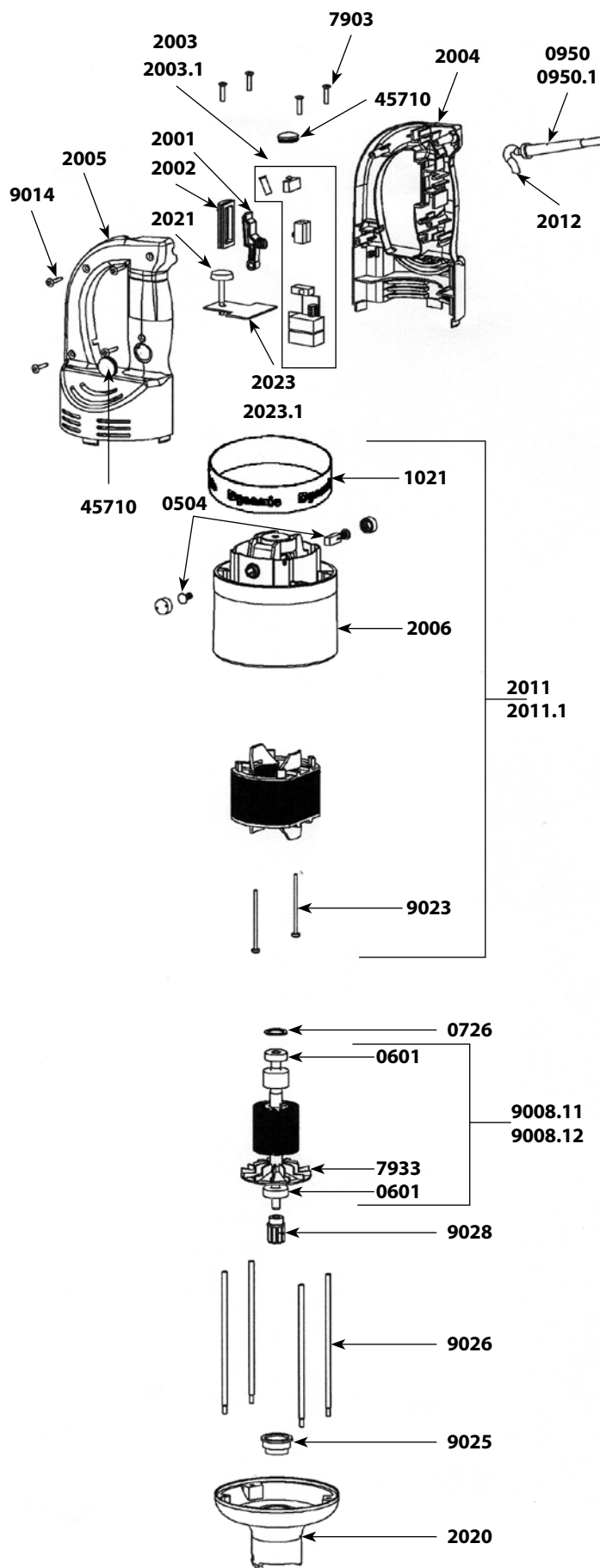

Parts list	Code
Motor brushes (2)	0504
Ball bearing	0601
Waterproof seal	0607
Squeezing washer	0726
Wall bracket	0862
Strain relief 230 V	0950
Strain relief 115 V	0950.1
Warning label	1017
Dynamic label	1021
ID label 115 V	1097
ID label 230 V	1099.15
Bearing holder + seal	1186
Control lever	2001
Safety control lever	2002
230 V electronic circuit board	2003DSC
115 V electronic circuit board	2003.1DSC
Half handle (no button)	2004
Half handle (button side)	2005
Motor housing brush holder	2006DSC
Complete foot assembly	2007
Foot assembly	2009
Stator 230 V	2011DSC
Stator 115 V	2011.1DSC
Power cord 230 V	2012
Power cord 115 V	2012.1
Variable speed control button	2021
Complete handle 230 V	2060
Complete handle 115 V	2060.1
Sensoring washer (washers, magnets, screws, small brace)	2061
Spacer screws (4)	7903
Emulsifying blade	7910
Lower bearing assembly	7916
Spacer cutter blade	7917
Fan	7933
Rotor 115 V	9008.11DSC
Rotor 230 V	9008.12DSC
Handle screws (4)	9014
Motor field screws (2)	9023
Motor ball bearing sleeve	9025
Spacer rods (4)	9026
Carbon brush wires (2) (230 V)	9043
Fitted shaft	9131
Carbon brush wires (2) (115 V)	9143
Shaft, lower ball bearing & cutter assembly	9164
Lower bearing screws (3)	9902
Rubber button cap	45710

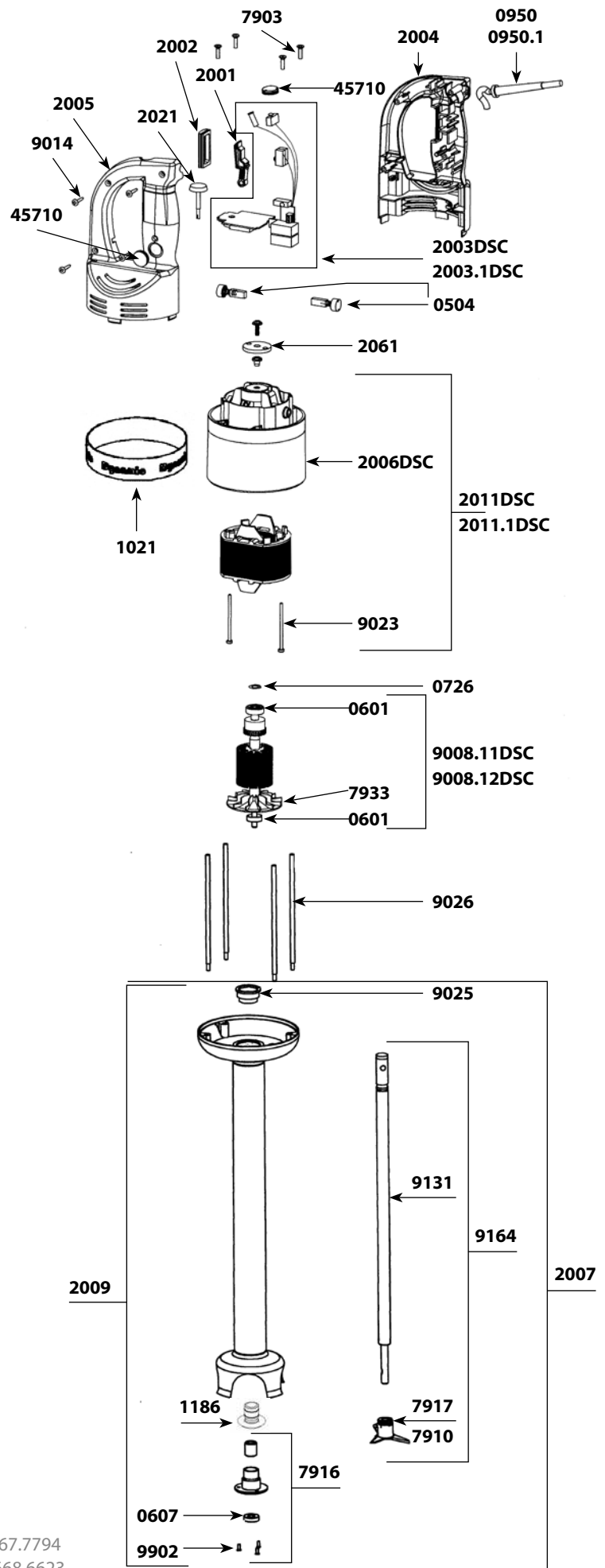

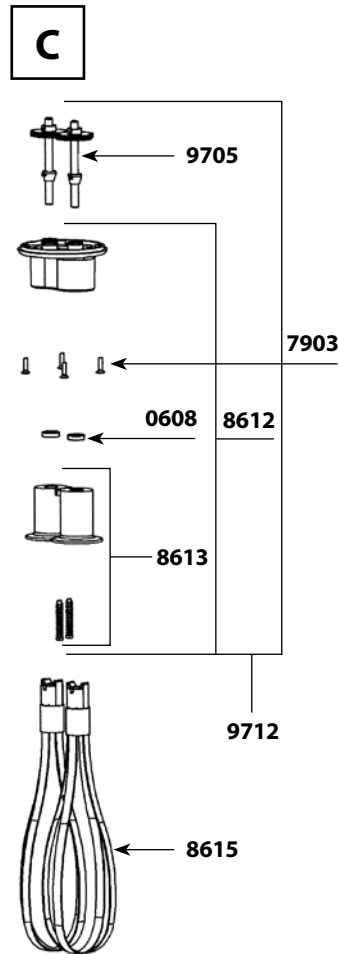
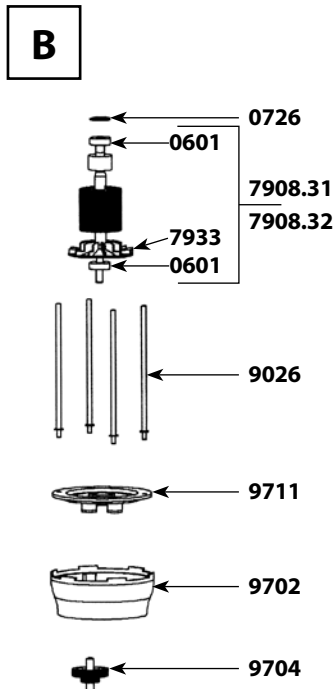
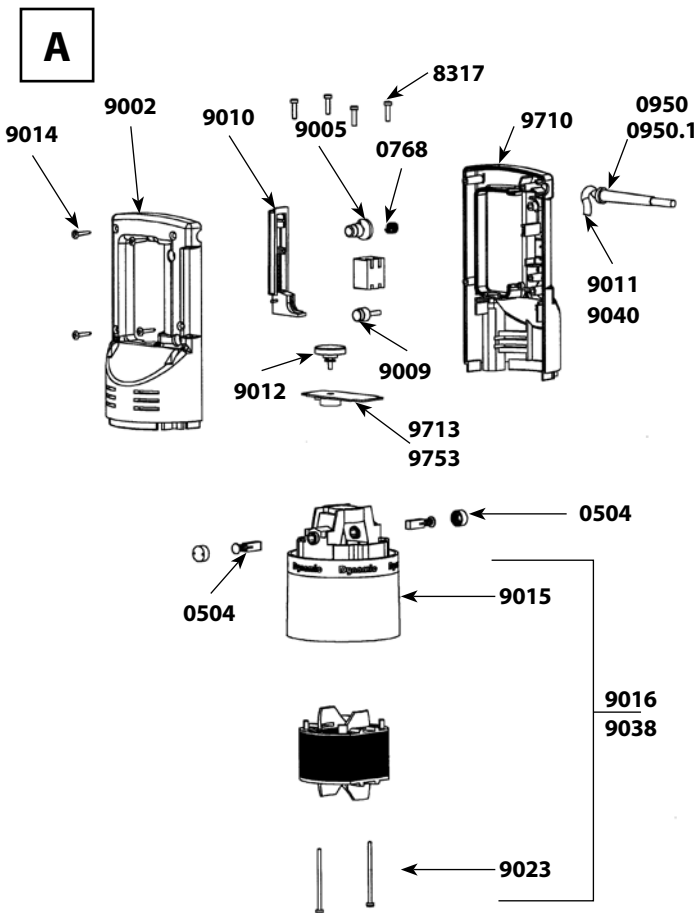

Parts list

Code

Motor brushes (2)	0504
Ball bearing	0601
Waterproof seal	0608
Squeezing washer	0726
Pin 3 X 20	0744
Pin 3 X 14	0745
Safety button return spring	0768
Wall bracket	0881
Strain relief 230 V	0950
Strain relief 115 V	0950.1
Switch 230 V	0964
Switch 115 V	0965
Capacitor	0972
Capacitor + filter	0972.1
ID label 115 V	1019
ID label 230 V	1020
Dynamic label	1027
Spacer screws (4)	7903
Rotor 115 V	7908.31
Rotor 230 V	7908.32
Fan	7933
Spacer screws (4)	8317
Holder + plastic ejector + seal (7903 not included)	8612
Plastic ejector (pair)	8613
Whisk (pair)	8615
Half handle (button side)	9002
Rubber button cap	9005
Plug	9009
Control lever	9010
Power cord 230 V	9011
Variable speed control button	9012
Handle screws (4)	9014
Motor housing brush holder	9015
Stator 230 V	9016
Motor field screws (2)	9023
Spacer rods (4)	9026
Stator 115 V	9038
Power cord 115 V	9040
Carbon brush wires 2 (230 V)	9043
Carbon brushe wires 2 (115 V)	9143
Lower aluminum housing	9702
Middle gear & shaft	9704
Output gear & shaft + Pins	9705
Complete handle 230 V	9706
Complete handle 115 V	9706.1
Half handle label side 230 V	9710
Half handle label side 115 V	9710.1
Plate w/ 3 seals	9711
Holder without gear (7903 not included)	9712
Variable speed control board 230 V	9713
Variable speed control board 115 V	9753

Parts list	Code
Motor brushes (2)	0523
Ball bearing	0601
Waterproof seal	0608
Squeezing washer	0726
Pin 3 X 20	0744
Pin 3 X 14	0745
Motor bushing	0829
Fan	0856
Hook	0860
Non-locking switch	0908
Capacitor	0909
Strain relief 230 V	0950
Strain relief 115 V	0950.1
Spacer screws (4)	7903
Brace	7913M
Power cord 230 V	8303
Power cord (UK)	8303.1
Spacer screws (4)	8317
Lower motor housing	8318
Top handle screws	8319
Ground wire	8321
Screws with ground washers (2)	8322
Motor housing brush holder	8510
Complete handle 230 V	8601
Handle only + cap + screws	8602
Equipped motor	8604
Variable speed control board 230 V	8608
Variator knob w/clips	8609
Middle gear & shaft	8610
Output gear & shaft	8611
Holder + 2 plastic ejectors + 2 seals + 3 rings	8612
Plastic ejector (pair)	8613
Lower aluminum housing	8614
Whisk only (pair)	8615
Complete axles, support, cones and pignons	8616
Stator 230 V	8617
Rotor 230 V	8618

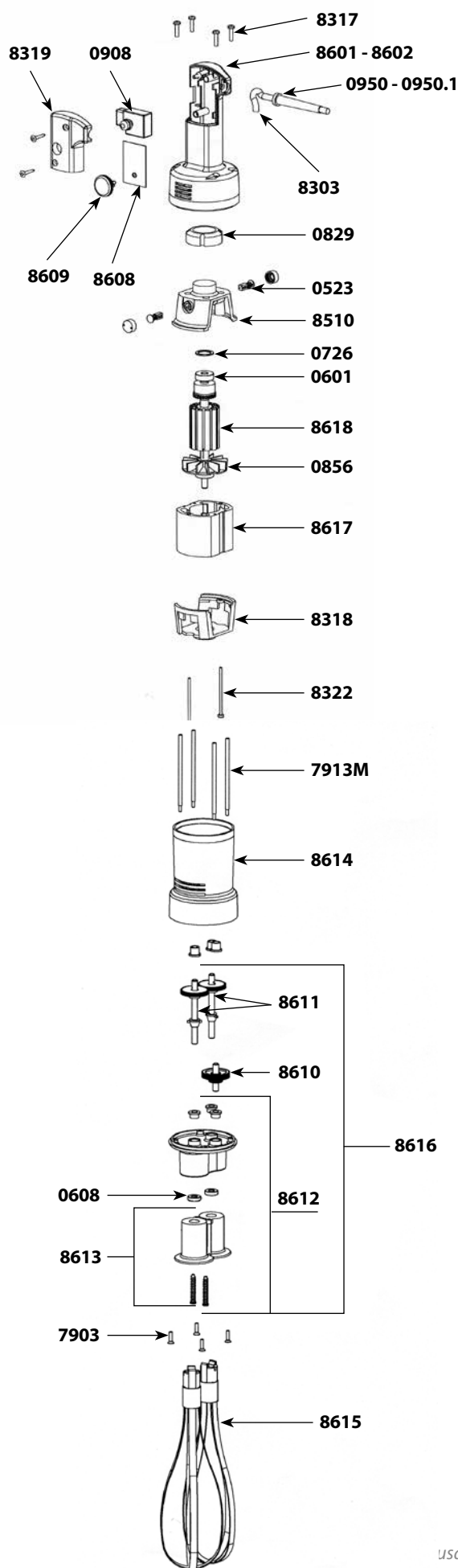

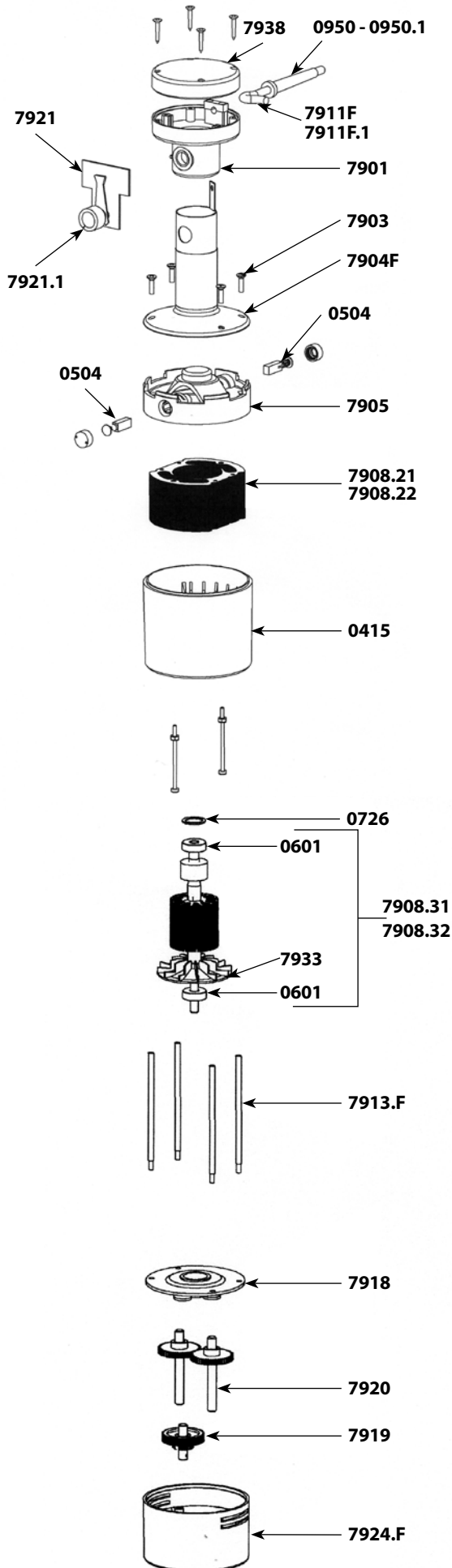

Parts list	Code
Sleeve	0415
Motor brushes (2)	0504
Ball bearing	0601
Waterproof seal	0608
Squeezing washer	0726
Pin 3 x 20	0744
Pin 3 x 14	0745
Strain relief 230V	0950
Strain relief 115V	0950.1
Complete handle	7901
Spacer screws (4)	7903
ID plate 230V	7904 F
Motor housing brush holder	7905
Stator 115 V	7908.21
Stator 230 V	7908.22
Motor 230 V	7908.3
Rotor 115 V	7908.31
Rotor 230 V	7908.32
Motor 115 V	7908.4
Power cord 230V	7911 F
Power cord 115V	7911 F.1
Spacer rods	7913.F
Plate assembly with 3 bronze seals	7918
Middle gear & shaft	7919
Output gear & shaft	7920
Variable speed control board	7921
Speed control plug	7921.1
Holder assembly w/ 3 self lubricating rings	7922
Plastic protector	7923
Lower housing	7924 F
Whisk (pair)	7925
Capacitor	7931
Fan	7933
Top handle w/screws	7938

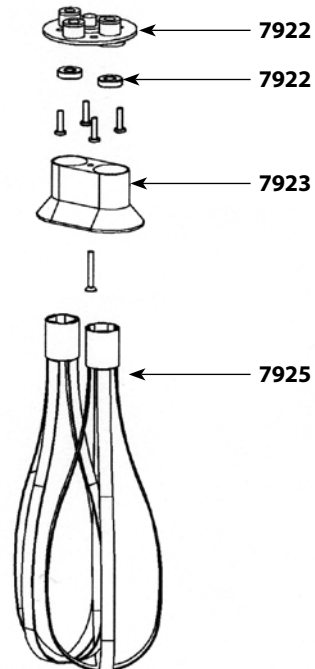

Parts list	Code
Motor brushes (2)	0504
Ball bearing	0601
Squeezing washer	0726
Lock button return spring	0767
Safety button. return spring	0768
Strain relief 230 V	0950
Strain relief 115 V	0950.1
Switch 230V	0964
Switch 115V	0965
Capacitor	0970
Capacitor + filter	0972.1
Warning label	1017
Dynamic label	1027
ID label 230 V	1030
ID label 115 V	1031
Fan	7933
Spacer screws (4)	8317
Complete handle 230 V	9000
Complete handle 115 V	9000.1
Lower half handle (label side) 230 V	9001
Lower half handle (label side) 115 V	9001.1
Upper half handle (button side)	9002
Rubber button cap	9005
Lock button	9007
Rotor 115 V	9008.11
Rotor 230 V	9008.12
Plug	9009
Control lever	9010
Power cord 230 V	9011
Variable speed knob	9012
Variable speed control board 230 V	9013
Handle screws (4)	9014
Motor housing brush holder	9015
Stator 230 V w/carter. motor brush holders not included	9016
Motor field screws (2)	9023
Lower aluminum housing	9024
Ball bearing sleeve	9025
Spacer rods (4)	9026
Coupler for armature	9028
Stator 115 V w/carter. carbon brush holders	9038
Power cord 115 V	9040
Carbon brush wires 230 V	9043
Variable speed control board 115 V	9053
Motor brush wires 115 V	9143

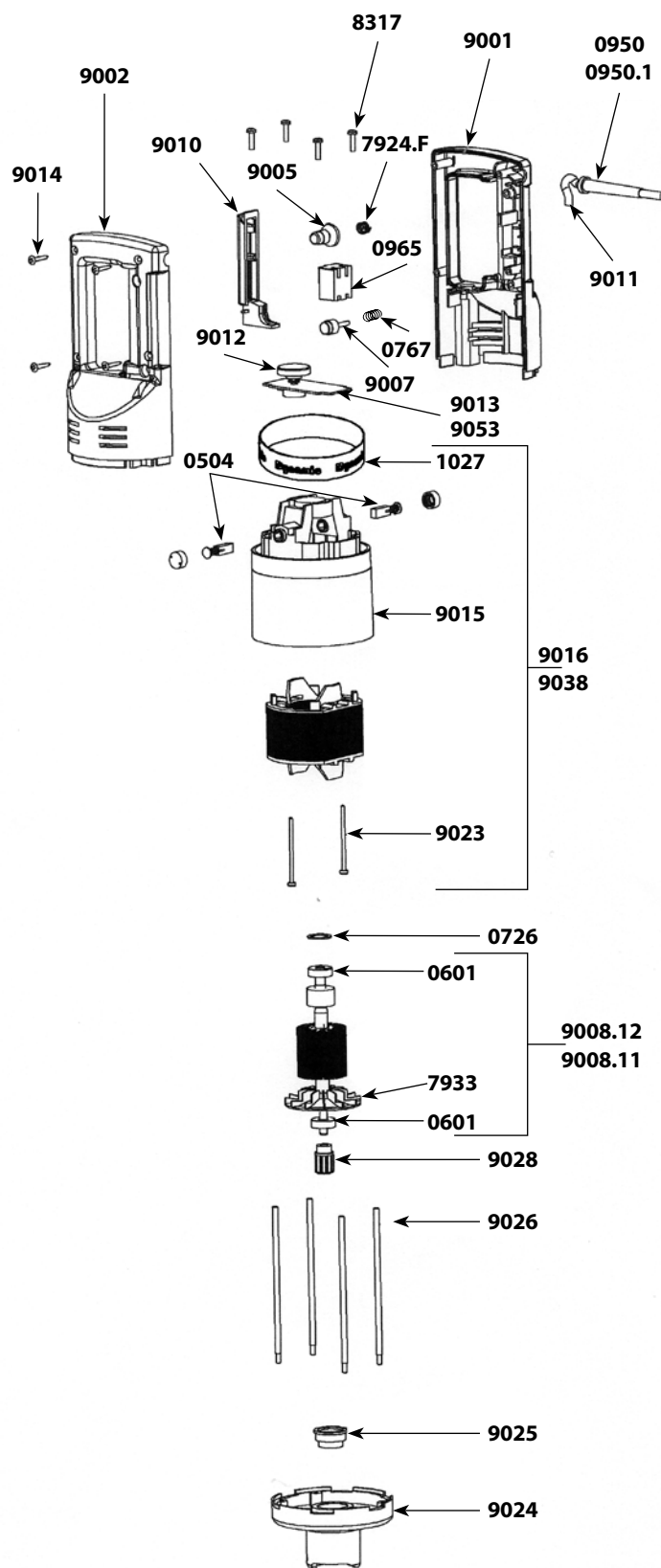

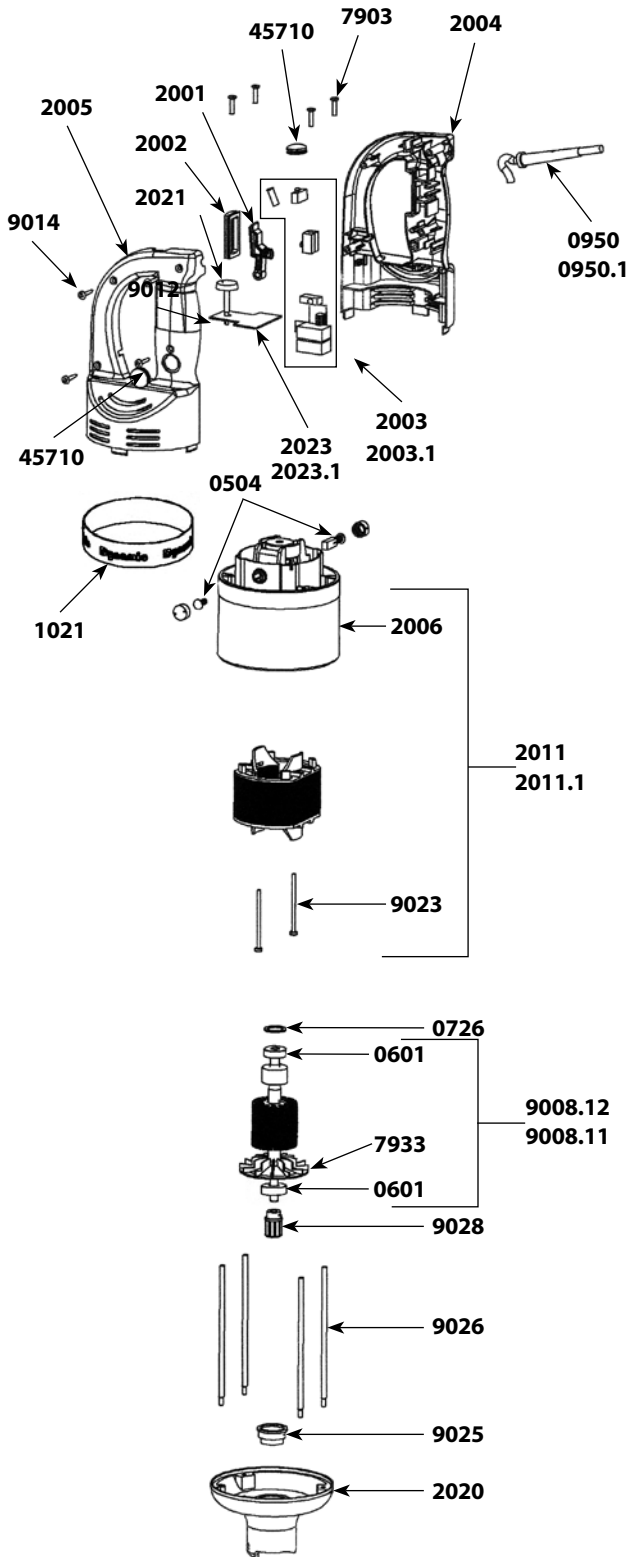

Parts list

Code

Motor brushes (2)	0504
Ball bearing	0601
Squeezing washer	0726
Safety button. return spring	0768
Strain relief 230 V	0950
Strain relief 115 V	0950.1
Filter C.E.M. 230 V	0999.20
Warning label	1017
Dynamic label	1021
ID label 230 V	1069
ID label 115 V	1070
Micro switch	1237
Power on indicator light 230 V	1241
Power on indicator light 115 V	1241.1
Control lever	2001
Control lever protector	2002
Circuit board 230 V (4 switches + capacitor)	2003
Circuit board 115 V (4 switches + capacitor)	2003.1
Half handle (no button)	2004
Half handle (button side)	2005
Motor housing + carbon brush holders	2006
Stator 230 V (carter + carbon brush holders)	2011
Stator 115 V (carter + carbon brush holders)	2011.1
Power cord 230 V > 2002	2012
Power cord 115 V > 2002	2012.1
Lower aluminum housing	2020
Variable speed knob	2021
Complete handle 230 V	2022
Complete handle 115 V	2022.1
Variable speed circuit board 230 V	2023
Variable speed circuit board 115 V	2023.1
Rubber button cap	45710
Spacer screws (4)	7903
Fan	7933
Rotor 115 V	9008.11
Rotor 230 V	9008.12
Power cord 230 V < 2002	9011
Handle screws (4)	9014
Motor field screws (2)	9023
Motor ball bearing sleeve	9025
Spacer rods (4)	9026
Coupler for armature	9028
Power cord 115 V < 2002	9040
Carbon brush wires 230 V	9043
Carbon brush wires 115 V	9143
BM 2000 motor block (see machine catalog)	AC001

MF 90/2000 & MFAP 90/2000 foot

Parts list	Code
Ball bearing	0601
Waterproof seal	0607
Lower bearing assembly support	1186
Emulsifying blade	7910
Lower bearing assembly	7916
Cutter blade w/screw	7917
Lower bearing screws (3)	7950
Shaft, lower bearing & cutter assembly	9004
Shaft	9031
Coupling casing + pin	9051
Tube assembly	9901
Lower ball bearing screws inox (3)	9902
M 90 Complete Mixer tool (see machine catalog)	AC002

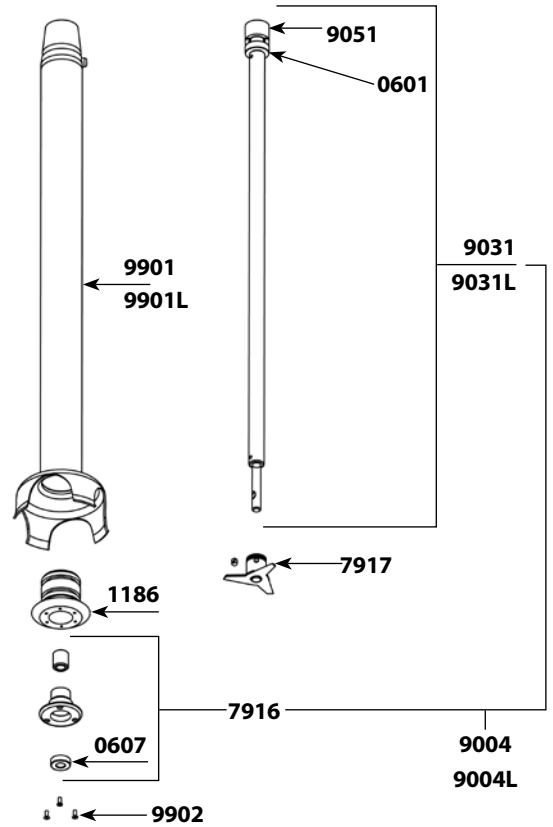

M100 foot

Parts list	Code
Shaft, lower bearing & cutter assembly	9004L
Shaft	9031L
Tube assembly	9901L

MF 90/2000 & MFAP 90/2000 whisk tool

Parts list	Code
Ball bearing	0601
Waterproof seal	0608
Pin 3 X 20	0744
Pin 3 X 14	0745
Spacer screws (4)	7903
Holder + plastic ejector + seal	8612
Plastic ejector (pair)	8613
Whisk (Pair)	8615
Reduction gear assembly	9034
Lower casing w/o middle gear	9046
Central double gear & shaft	9048
Single gear (2)	9049
Upper plastic casing	9050
Coupling casing + pin	9051
Equipped upper shaft	9055
Complete upper casing	9057
F 90 Complete Whisk tool (see machine catalog)	AC003

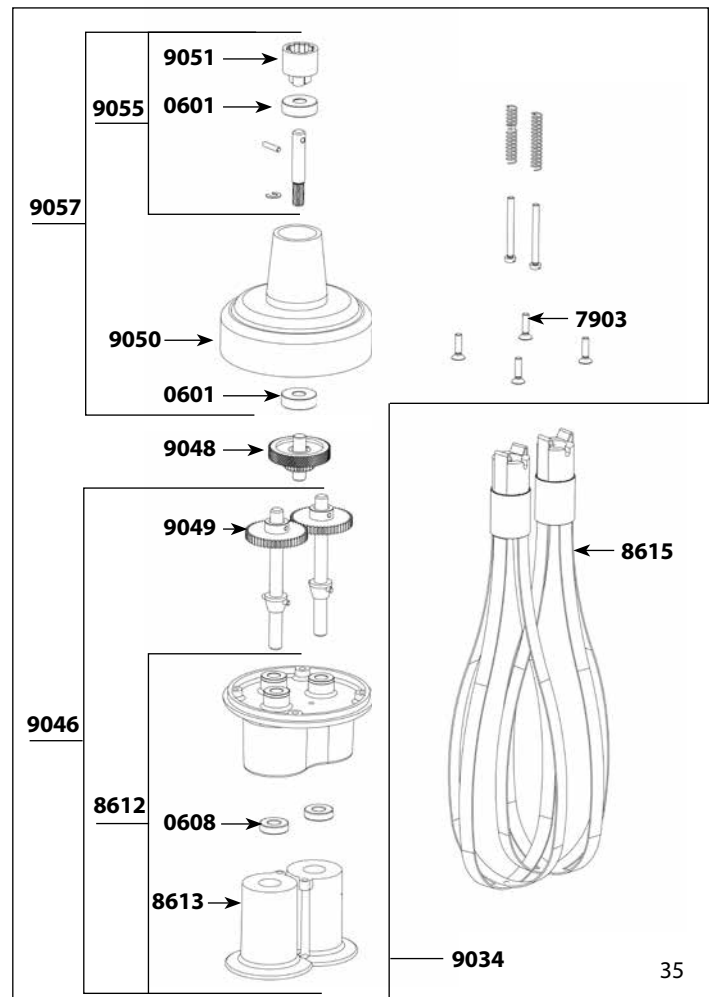

Wall bracket

Parts list	Code
Wall bracket	0880

MF 90/2000 & MFAP 90/2000 foot - Ref AC002.H (Complete attachment)

Parts list	Code
Ball bearing	0601
Self-lubricating ring	0603
Waterproof seal	0607
O. ring	0610PD
Tube assembly + bearing	1431
Bell	1432
Cutter blade w/ screw	7917
Coupler for armature	9028
Shaft	9031
Coupling casing + pin	9051
Black tip	9847.M90

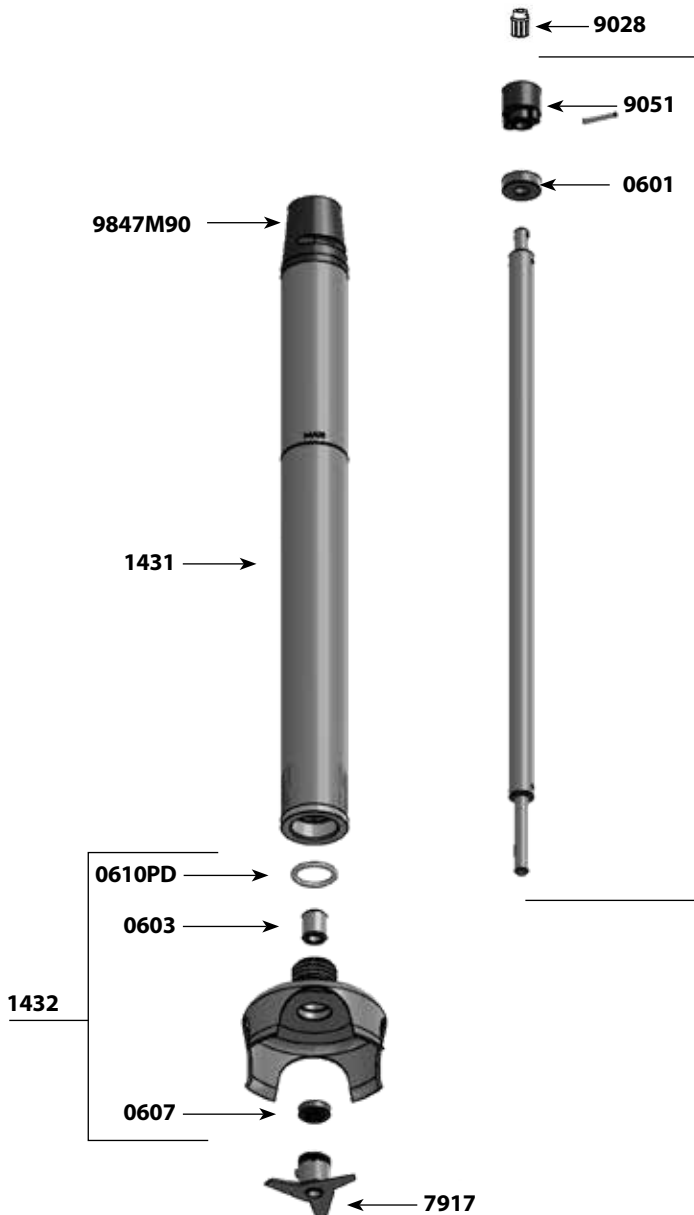

PIED BLENDER MASTER - Ref AC070 (Complete attachment)

Parts list	Code
Ball bearing	0601
Seals for bearing assembly (2)	0618
Self-lubricating ring	0666
Waterproof seal	0667
Foot assembly	1401
Blender bell	1402
Cutter blade	1403
Shaft	1404
Blender key	1405
Coupler for armature	9028
Coupling casing + pin	9051
Black tip	9847.M90

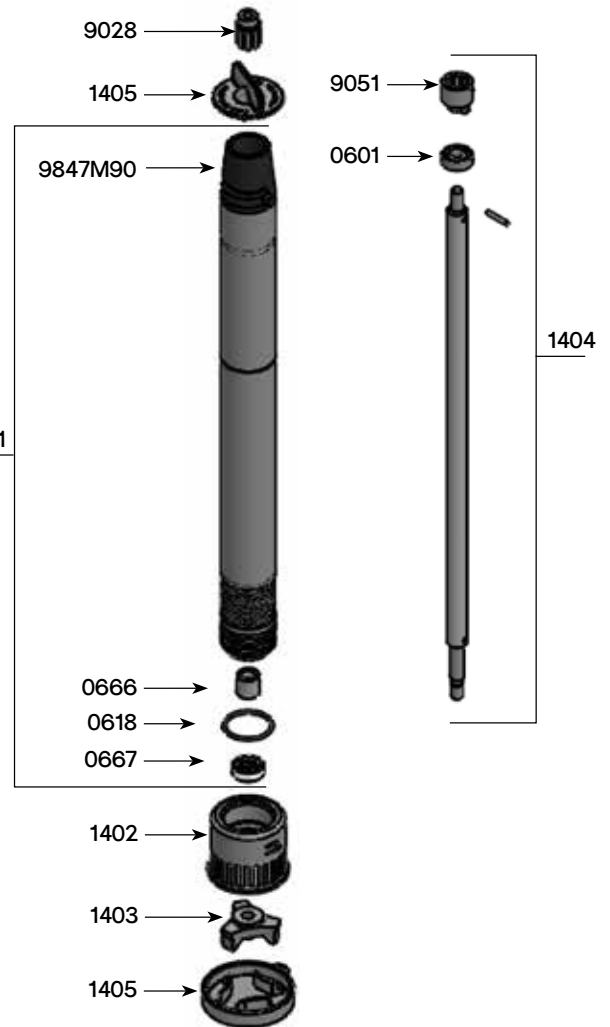

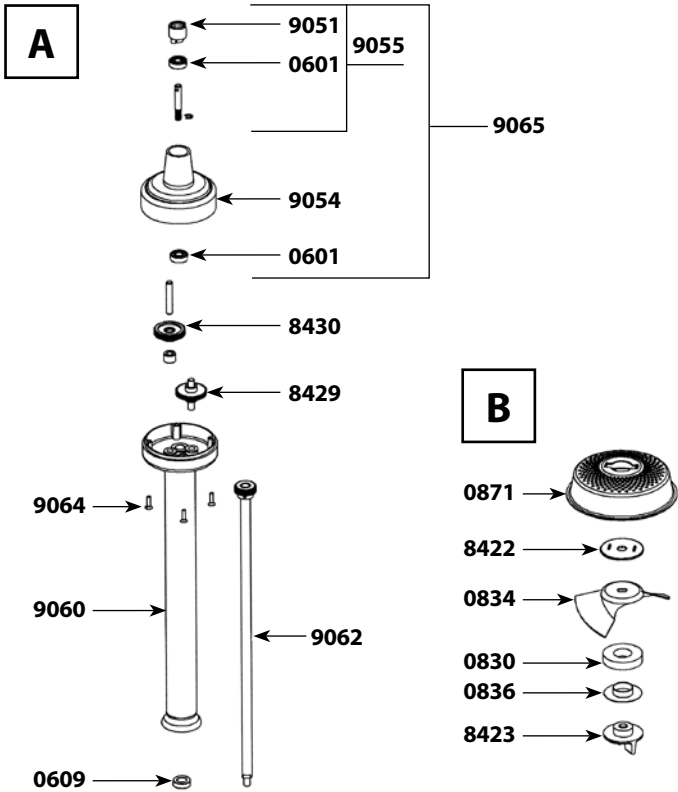

Parts list	Code
Waterproof seal	0609
Rubber washer	0830
Blade	0834
Washer friction	0836
Grid	0871
Anti-friction washer	8422
Lower bolt	8423
Double gear with washer	8429
Single gear & shaft	8430
Coupling casing w/pin	9051
Reducing casing & seal	9054
Equipped upper shaft	9055
Foot assembly	9060
Main shaft + gear	9062
Reduction casing screws (4)	9064
Complete reduction box	9065

MASTER WHIP FM SERIES

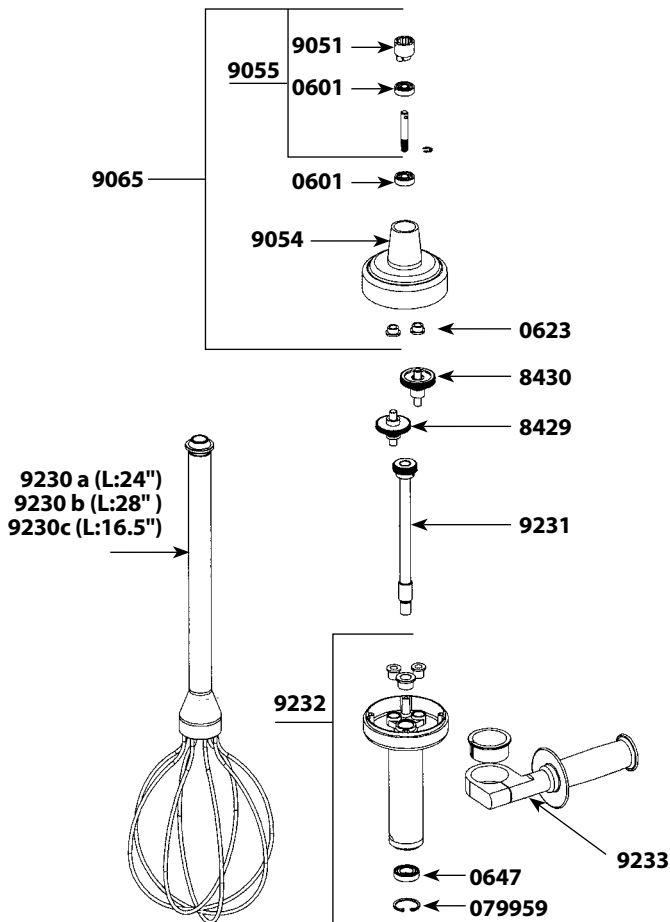

Parts list	Code
Ball bearing	0601
Bushing (1)	0623
Bearing	0647
Circlips	079959
Double gear with washer	8429
Middle gear & axle	8430
Coupling casing w/pin	9051
Reducing casing+2 seals	9054
Equipped upper shaft	9055
Complete reduction box	9065
Mono whisk / L : 24"	9230 a
Mono whisk / L : 28"	9230 b
Mono whisk / L : 16.5"	9230 c
Main shaft	9231
Lower carter	9232
Handle + casing	9233
Complete reduction box w/ out bowl whisk and handle	9250

Parts list	Code
Sleeve	0415
Motor brushes w/caps (2)	0504
Ball bearing	0601
Waterproof seal	0609
Squeezing washer	0726
Pin 3 x 14	0745
Rubber washing	0830
Fan	0835
Washer friction	0836
Rice grid	0842
Push button switch	0905
Strain relief 230 V	0950
Strain relief 115 V	0950.1
Equipped handle	7901
Spacer screws (4)	7903
Upper carter w/carbon brush holders	7905
Stator 230 V	7908.22
Stator 115 V	7908.21
Rotor 230 V	7908.32
Rotor 115 V	7908.31
Power cord 230 V	7911M
Power cord 115 V	7911M.1
Spacer rods (4)	7913F
Capacitor	7931
Fan	7933
Handle cap w/screws	7938
Identification plate 230 V	8404
Identification plate 115 V	8404.1
Motor 230 V	8408
Motor 115 V	8408.1
Foot assembly	8419
Antifriction washer	8422
Lower bolt	8423
Output shaft w/ gear	8428
Double gear with washer	8429
Middle gear & axle	8430
Plate w/ 2 seals	8431

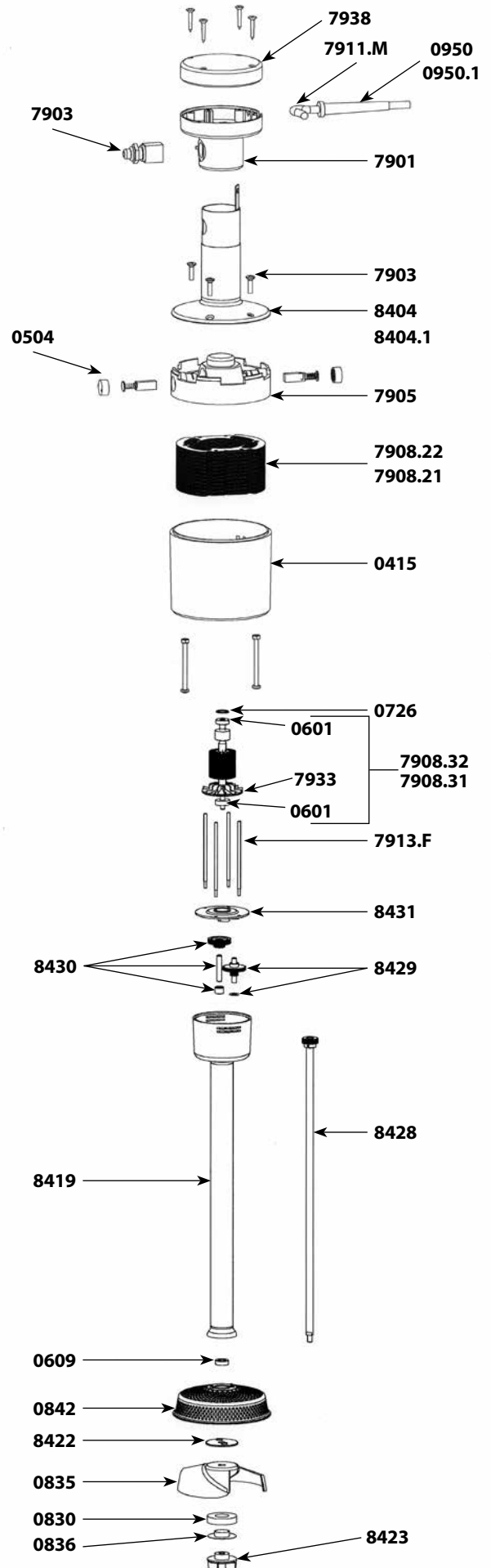

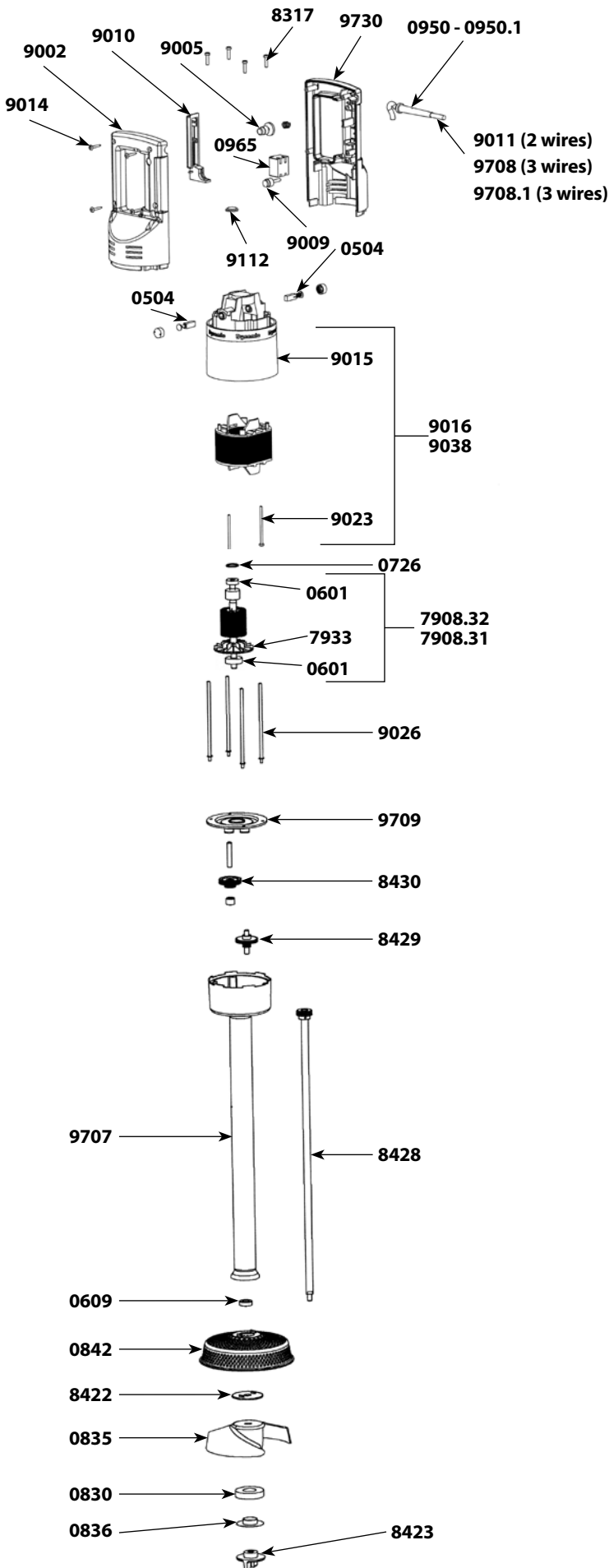

Parts list

Code

Motor brushes (2)	0504
Ball bearing	0601
Waterproof seal	0609
Squeezing washer	0726
Pin 3 x 14	0745
Safety button return spring	0768
Rubber washing	0830
Fan	0835
Washer friction	0836
Ricer grid	0842
Wall bracket	0881
Strain relief 230V	0950
Strain relief 115 V	0950.1
Switch 230 V	0964
Switch 115 V	0965
Capacitor	0972
Capacitor + filter	0972.1
Dynamic label	1027
ID label 230 V	1056
ID label 115 V	1057
Rotor 115 V	7908.31
Rotor 230 V	7908.32
Fan	7933
Spacer screws (4)	8317
Antifriction washer	8422
Lower bolt	8423
Output shaft w/ gear	8428
Double gear with washer (from N°050025)	8429
Middle gear & axle	8430
Upper half handle	9002
Rubber button cap	9005
Plug	9009
Control lever	9010
Power cord 2 cond. 230 V (from N°050025)	9011
Handle screws (4)	9014
Motor housing w/carbon brush holders	9015
Stator 230 V w/carter carbon brush holders	9016
Stator screws (2)	9023
Spacer rods (4)	9026
Stator 115 V w/carbon brush holders	9038
Power cord 115 V w/carbon brush holders (from N°050025)	9040
Carbon brush wires 230 V	9043
Power cord (Australian) (from N°050025)	9066
Power cord (UK) (from N°050025)	9067
Speed control plug	9112
Carbon brush wires 115 V	9143
Complete handle 230 V	9700
Complete handle 115 V	9700.1
Complete foot assembly	9707
Power cord + Label 230 V (from N°050025) 3 wires	9708
Power cord + Label 115 V (from N°050025) 3 wires	9708.1
Plate w/ 2 seals	9709
Lower half handle (label side) 230 V	9730
Lower Half handle (label side) 115 V	9740

MOTOR BLOCK PP 97 PLUS

Parts list	Code
Motor brushes	0504
Ball bearing	0601
Rubber washer	0726
Safety button return spring	0768
Strain relief 230 V	0950
Strain relief 115 V	0950.1
Switch	0965
Capacitor (115 V)	0972
Capacitor + filter	0972.1
Dynamic label	1027
Identification plate 230 V	109913
Identification plate 115 V	109914
Rotor 230 V	7908.31
Rotor 115 V	7908.32
Fan	7933
Spacer screws	8317
Upper half handle	9002
Security cap	9005
Handle cap	9009
Control lever	9010
Variable speed knob	9012
Variable speed control board 230 V	9013
Handle screw	9014
Top housing	9015
Stator 230 V	9016
Stator screws 230 V (2)	9023
Stator 115 V	9038
Power cord 115 V	9040
Carbon brush wires (230 V)	9043
Variable speed control board 115 V	9053
Variator cap	9112
Carbon brush wires 115 V (2)	9143
Lower half handle 230 V (with label)	9730
Lower half handle 115 V (with label)	9740
Lower motor housing	9761
Complete handle w/power cord 230 V	9765
Complete handle w/power cord 115 V	9765.1

Equipped lower carter PP97 plus

Parts list	Code
M4 Washer	0769
Double gear with washer	8429.1
Middle gear axle	8430
Spacer rods	9026
Handle support	9233
Plate w/ 2 seals	9709
Exit shaft w/gear	9762
Aluminium carter. foot and seals	9764

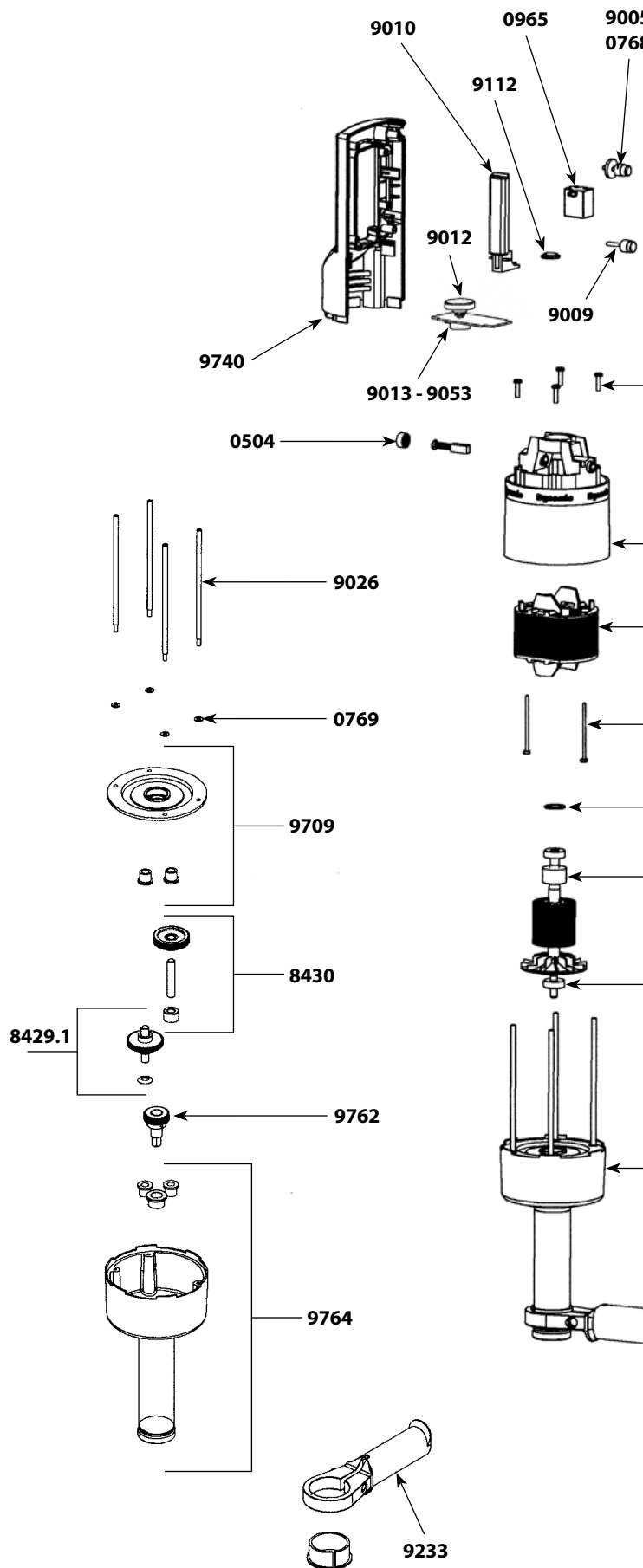

Whip tool for PP97 plus - FM97

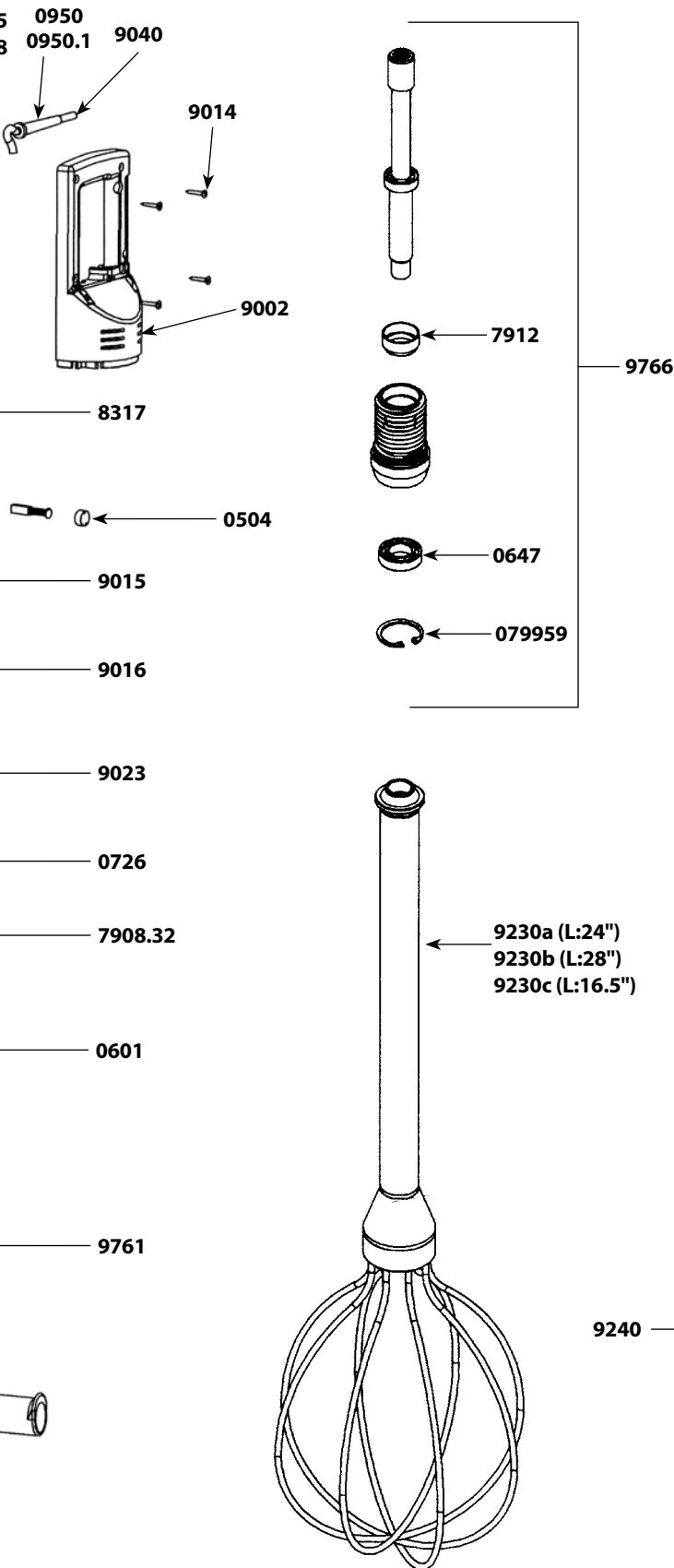

Parts list

Code

D15 Bearing	0647
Rubber ring	079959
Ball bearing	7912
Mono whisk L: 24"	9230a
Mono whisk L: 28"	9230b
Mono whisk L: 16.5"	9230c
Equipped male casing (shaft, bearing seal, ball bearing, rubber ring)	9766

AP 97 for Ricer tool

Parts list

Code

Waterproof seal	0609
Toric seal	0641
Rubber washing	0830
Fan	0835
Friction washer	0836
Ricer grid	0842
Bearing seal	7912
Antifriction seal	8422
Lower bolt	8423
Equipped male casing, bearing seal, tube and complete lever assembly	9240
Exit shaft	9241

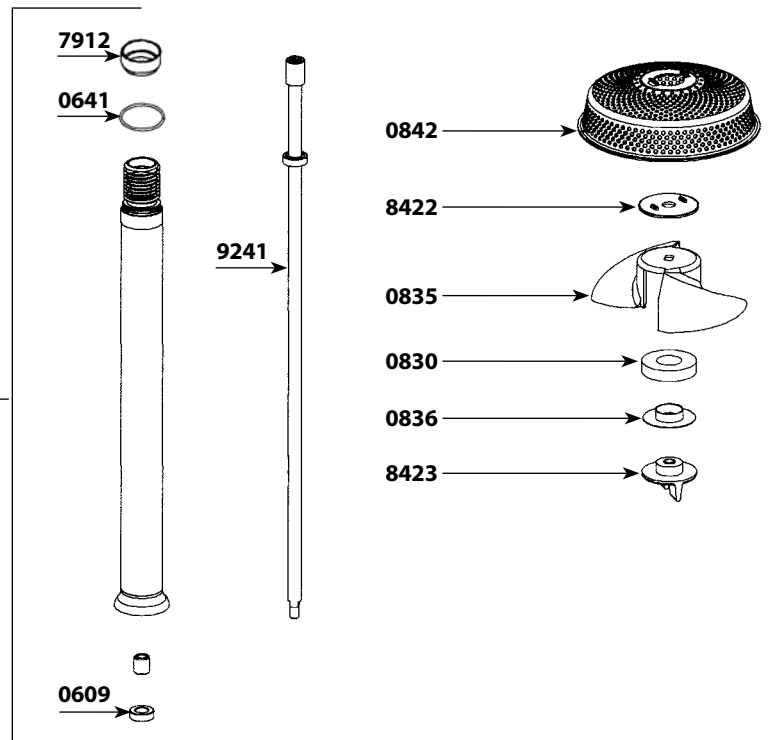

Parts list	Code
Fan	0509
Motor brushes (pair)	0529
Ball bearing	0601
Motor ball bearing	0602
Rubber ring	0760
Clips	0776
Washer & bolt for fan	0777
Wall bracket	0862
Rocking switch	0903
Capacitor	0909
Strain relief 230 V	0950
Strain relief 115 V	0950.1
Push button switch	0990
ON/OFF label	1008
Foot assembly (tube, bearing, assembly)	45110
Shaft & ball bearing	45120
Coupling sleeves	45122
Motor & shaft drive sprocket	45123
Fan housing (no motor brushes)	45125
Lower bearing assembly	45130
Brush holder w/ cap (1) 230 V	45131
Brush holder w/ cap (1) 115 V	45131.1
Lower motor casing	45132
Upper motor casing	45133
Stator 230 V	45135
Stator 115 V	45135.1
Rotor 230 V	45136
Rotor 115 V	45136.1
Stator screws (2)	45137
Spacer rods (4)	45138
Spacer screws (4)	45139
ID plate	45144
Cutter blade w/screw	45161
Motor 115 V	45200.1
Motor 230 V	45200.2

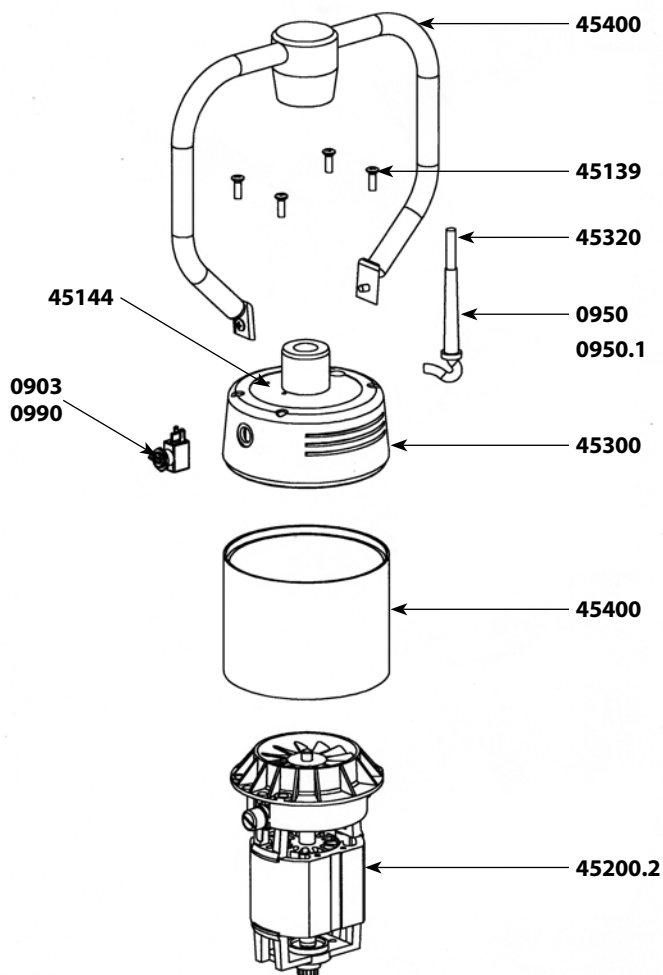

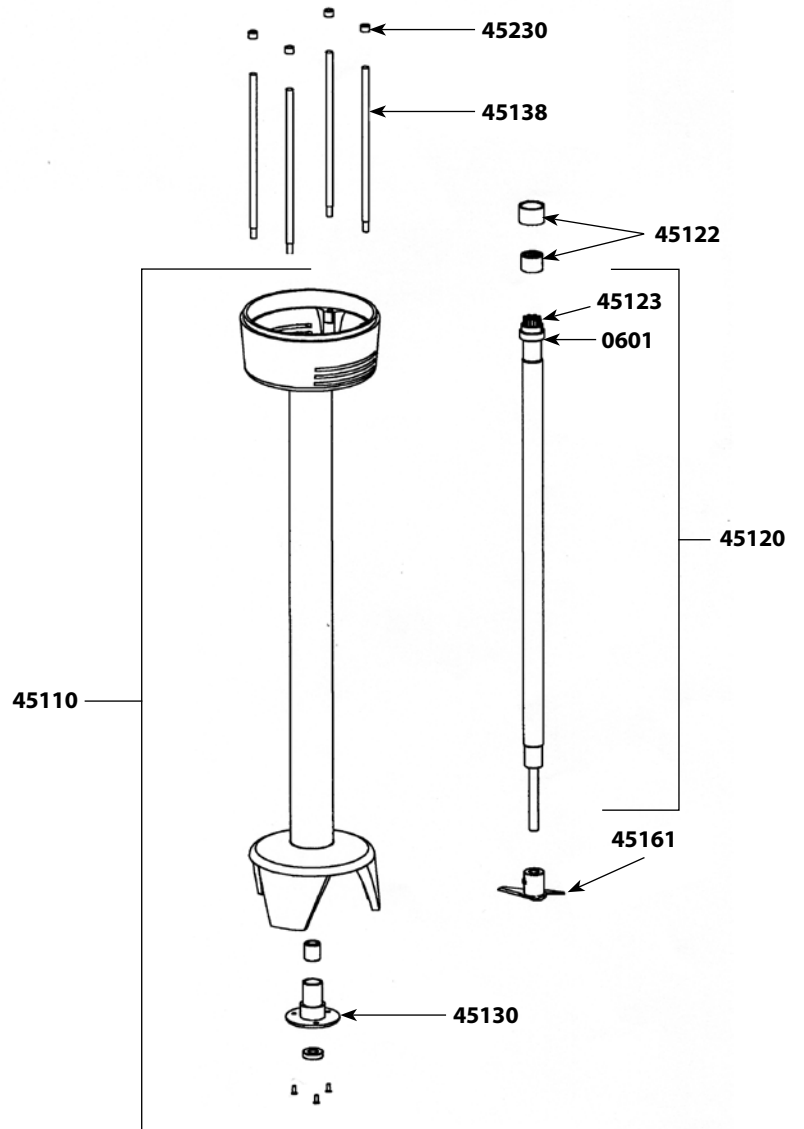
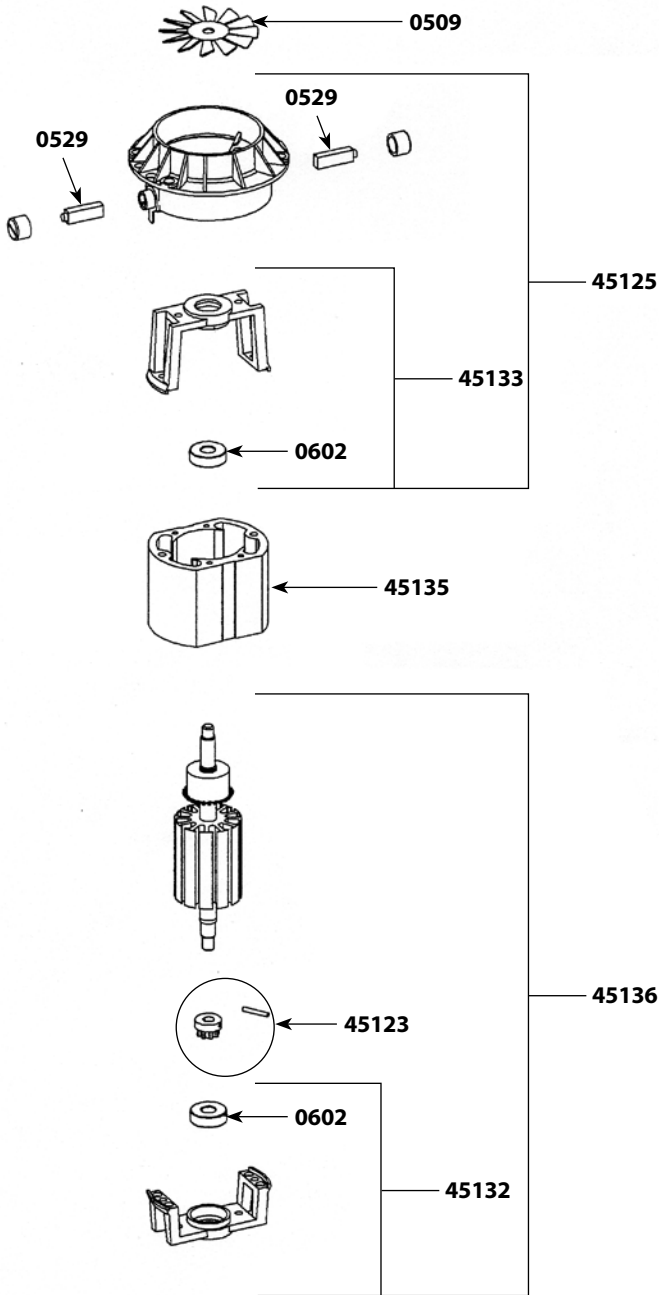

Parts list

Code

Squeezing washer (4)	45230
Upper carter 230 V	45300
Upper carter 115 V	45300.1
Power cord 230 V	45320
Power cord 115 V	45320.1
Complete handle	45400
Sleeve	45500
Kit w/ shaft, lower bearing, coupler, cutter	45533
Conversion kit (SMX450 to SMX500)	45600
Perforated disc	45810
Perforated disc w/ pin	45820
Bearing screws for aluminium bell (3)	7950
Lower bearing screws (3)	9902

Parts list

Code

Turbine	0509
Motor brushes (pair)	0529
Ball bearing	0601
Motor ball bearing	0602
Waterproof seal	0607
Spring	0760
Clips	0776
Washer & bolt for fan	0777
Wall bracket	0862
Locking switch	0907
Non-locking switch	0908
Capacitor	0909
Strain relief 230 V	0950
Strain relief 115 V	0950.1
Lower bearing assembly support	1185
Shaft & ball bearing	45120
Coupling sleeves	45122
Motor & shaft drive sprocket	45123
Fan housing	45125
Lower bearing assembly	45130
Brush holder w/ cap (1)	45131
Brush holder w/ cap (1)	45131.1
Lower motor casing	45132
Upper motor casing	45133
Stator 230 V	45135
Stator 115 V	45135.1
Rotor 230 V	45136
Rotor 115 V	45136.1
Stator screws(2)	45137
Spacer rods (4)	45138
Spacer screws (4)	45139
Cutter blade w/screw	45161

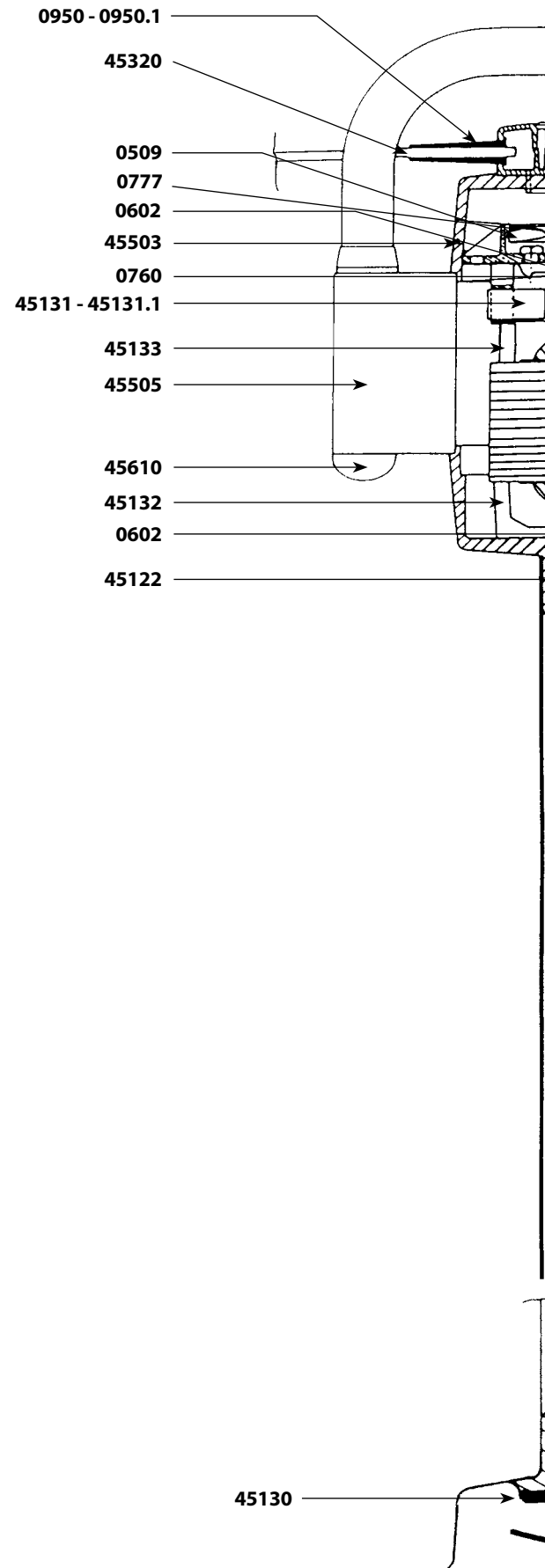

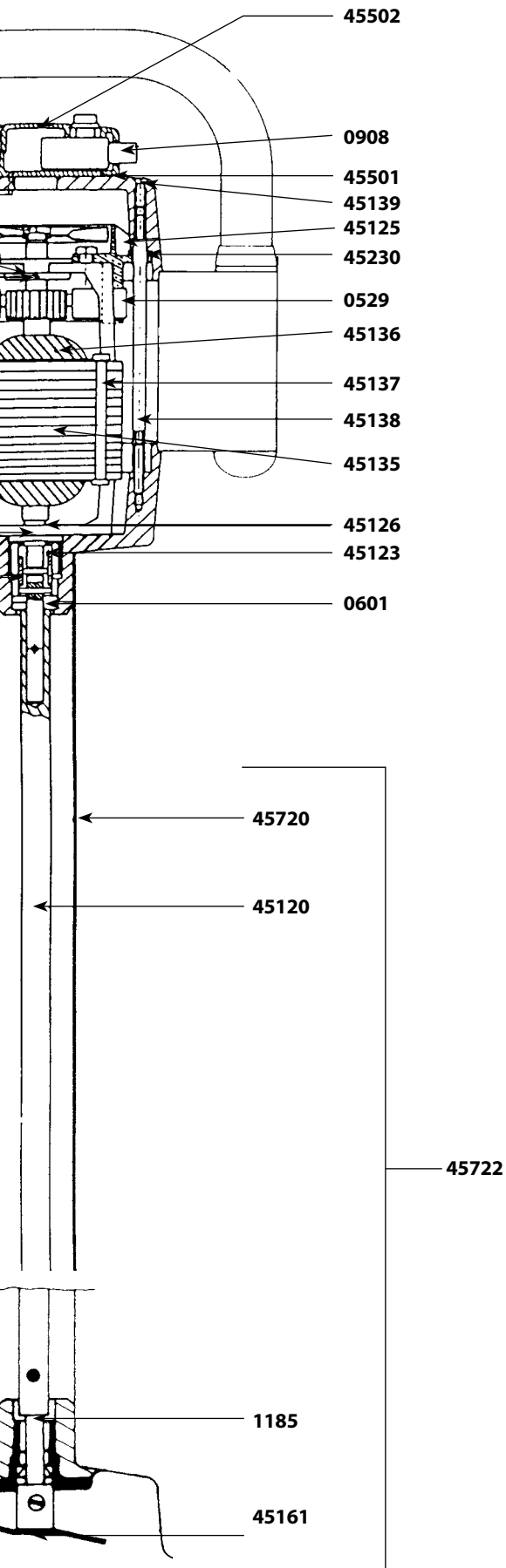

Parts list

Code

Double isolation part	45126
Motor 115 V	45200.1
Motor 230 V	45200.2
Squeezing washers (4)	45230
Power cord 230 V	45320
Power cord 115 V	45320.1
Lower housing (orange plastic piece)	45501
Upper housing (orange plastic piece)	45502
Top housing	45503
Sleeve & complete handle	45505
Complete housing w/ screws	45510
Kit w/ shaft, lower bearing, cutter	45533
Handle cap (2)	45610
Foot assembly	45720
Complete foot assembly	45722
Perforated disc	45810
Perforated disc w/ pin	45820
Lower bearing screws for aluminium bell (3)	7950
Lower bearing screws (3)	9902

Parts list	Code
Fan	0509
Motor brushes (pair)	0529
Ball bearing	0601
Motor ball bearing	0602
Self-lubricating ring	0603
Waterproof seal	0607
O. ring	0610
Rubber washer	0760
Clips	0776
Washer & bolt for fan	0777
Wall bracket	0862
Locking switch	0907
Non-locking switch	0908
Capacitor	0909
Strain relief 115 V	0950.1
ID label 115 V	1049
Lower bearing assembly support	1185
Lower bearing screws for aluminium bell (3)	7950
Power cord 115 V	9040
Bearing support screws (3)	9902
Stainless steel lower bearing screws (3)	9902.1
Shaft & ball bearing	45120
Coupling sleeves	45122
Motor & shaft drive sprocket	45123
Fan housing	45125
Double isolation part	45126
Lower bearing assembly	45130
Complete stainless steel lower bearing	45130.1
Lower motor casing	45132
Upper motor casing	45133

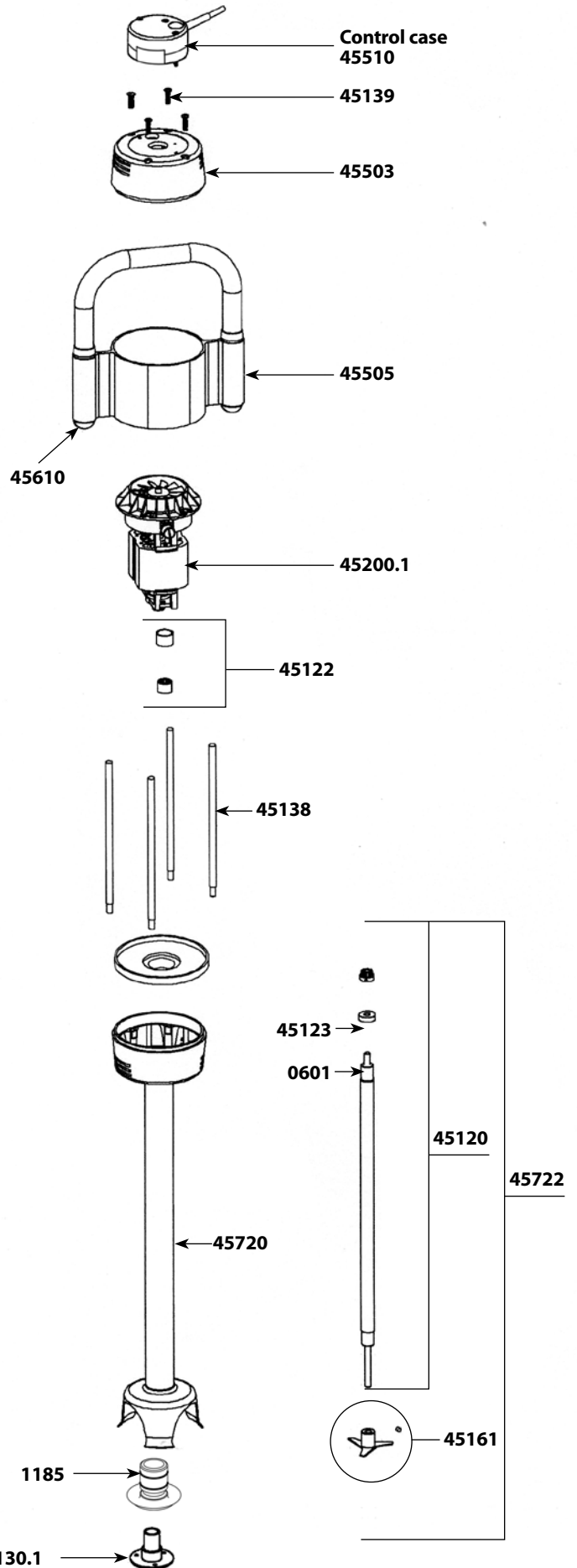

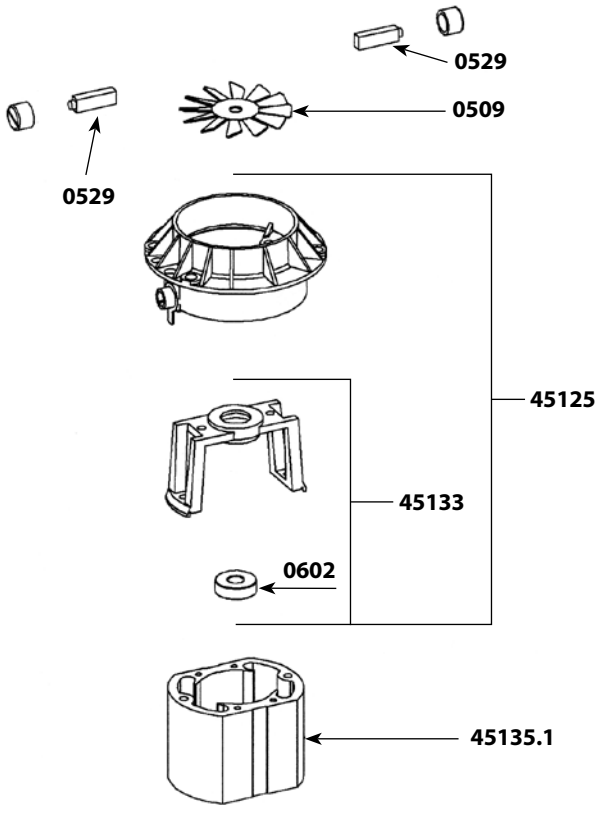

Parts list	Code
Stator 230 V	45135
Stator 115 V	45135.1
Rotor 230 V	45136
Rotor 115 V	45136.1
Stator screws (2)	45137
Spacer rods (4)	45138
Spacer screws (4)	45139
Cutter blade w/ screw	45161
Motor 115 V	45200.1
Motor 230 V	45200.2
Squeezing washer (4)	45230
Lower housing (orange plastic piece)	45501
Upper housing (orange plastic piece)	45502
Top housing	45503
Sleeve & complete handle	45505
Complete housing w/ screws	45510
Kit w/ shaft, lower bearing, coupler, cutter	45533
Handle cap (2)	45610
Circuit Board 115 V	45620.1
Foot assembly	45720.1
Locking kit	45721
Complete foot assembly	45722
Perforated disc	45810
Perforated disc w/ pin	45820

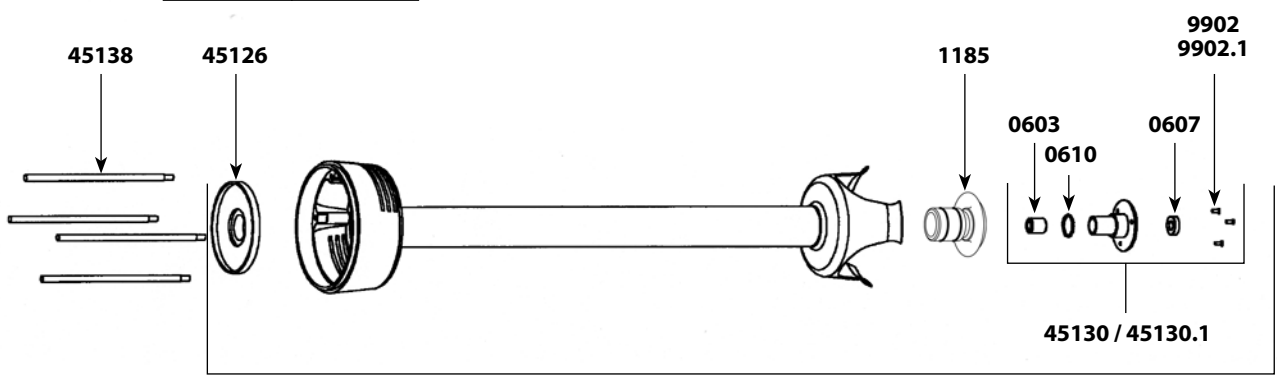
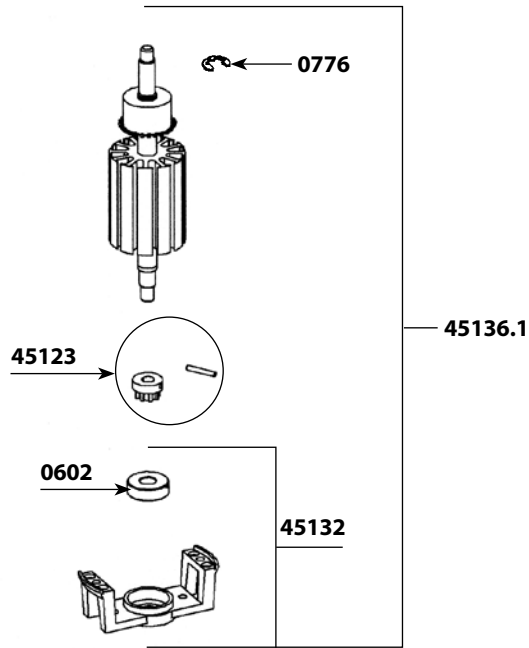

45720.1

Parts list	Code
Aluminium Fan	0509
Motor brushes (pair)	0529
Ball bearing	0601
Motor ball bearing	0602
Self-lubricating ring	0603
Waterproof seal	0607
O. ring	0610
Rubber washer	0760
Clips	0776
Washer & bolt for fan	0777
Wall bracket	0862
Strain relief 115 V	0950.1
ID label 115 V	1009
Lower bearing assembly support	1185
Shaft, ball bearing + sprocket	45120
Coupling sleeves	45122
Motor & shaft drive sprocket	45123
Fan housing Plastic	45125.P
Double isolation part	45126
Lower ball bearing assembly	45130
Complete stainless steel lower bearing	45130.1
Brush Holder w/cap (1)	45131
Lower motor casing	45132
Upper motor casing	45133
Stator 115 V	45135.1
Rotor 115 V	45136.1
Stator screws (2)	45137

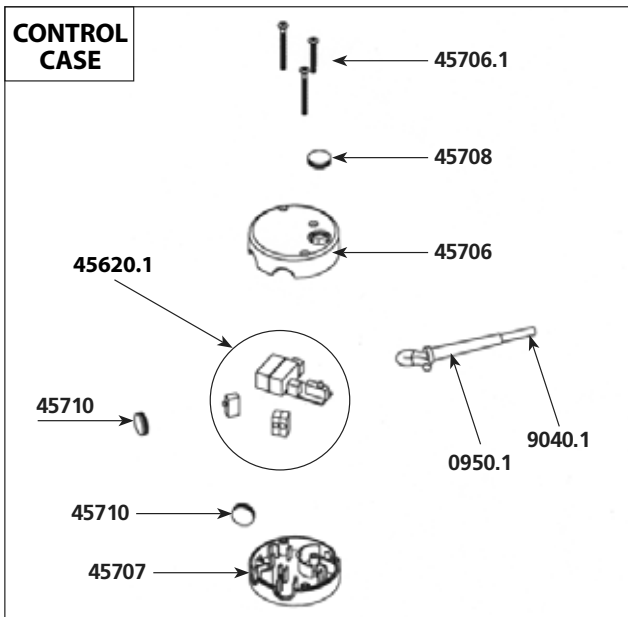
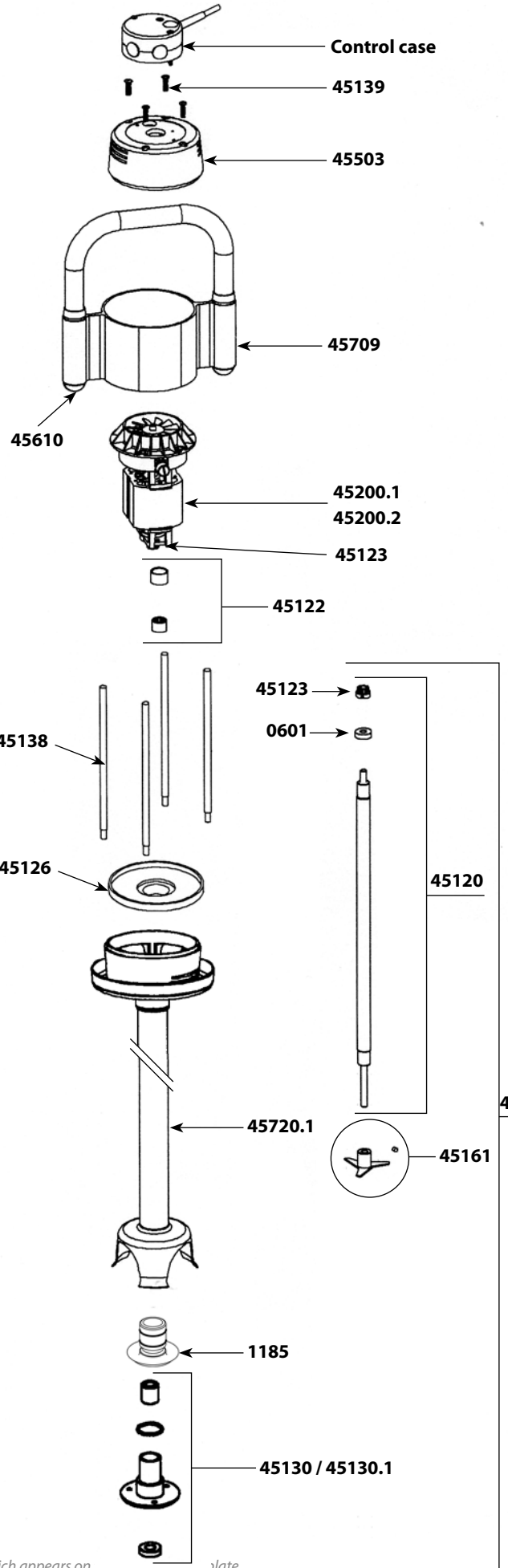

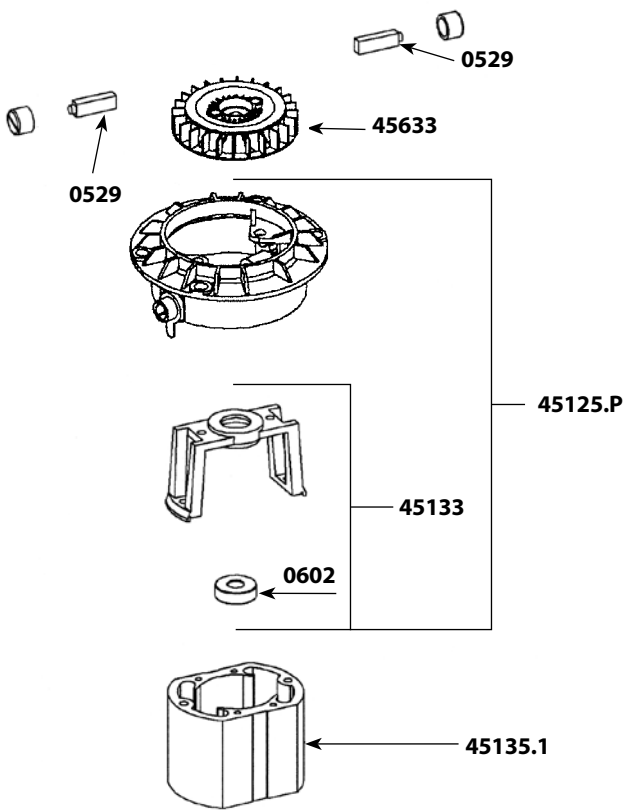

Parts list	Code
Spacer rods (4)	45138
Spacer screws (4)	45139
Cutter blade w/screw	45161
Motor 115 V	45200.1
Motor 230 V	45200.2
Squeezing washers (4)	45230
Top housing	45503
Kit w/ shaft, lower bearing, coupler, cutter	45533
Handle cap (2)	45610
Circuit board 115V	45620.1
Plastic Fan	45633
Top housing (orange plastic piece)	45706
Screws control case set	45706.1
Lower housing (orange plastic piece)	45707
Handle cap protector (unit)	45708
Sleeve & complete handle & label & cap	45709
Handle cap protectors (unit)	45710
Orange housing w/ screws	45711
Foot assembly w/ lower bearing	45720.1
Complete foot assembly	45722.1
Power cord 115 V	9040.1
Bearing support screws (3)	9902
Stainless steel lower bearing screws (3)	9902.1

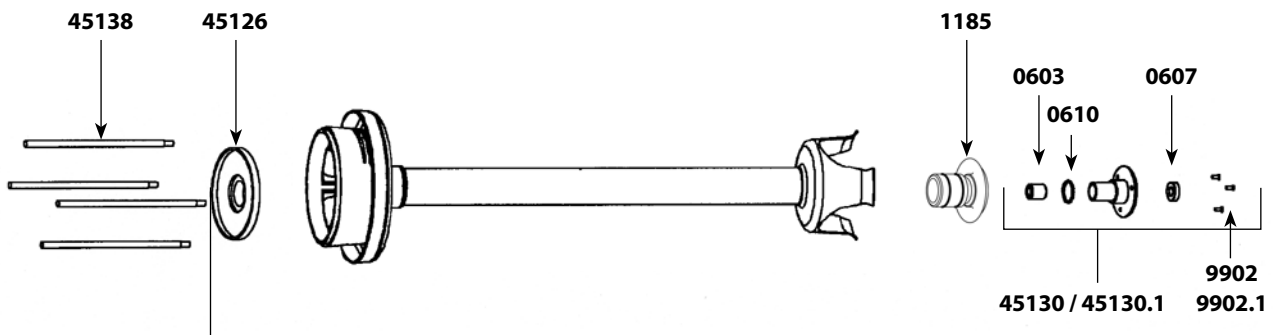
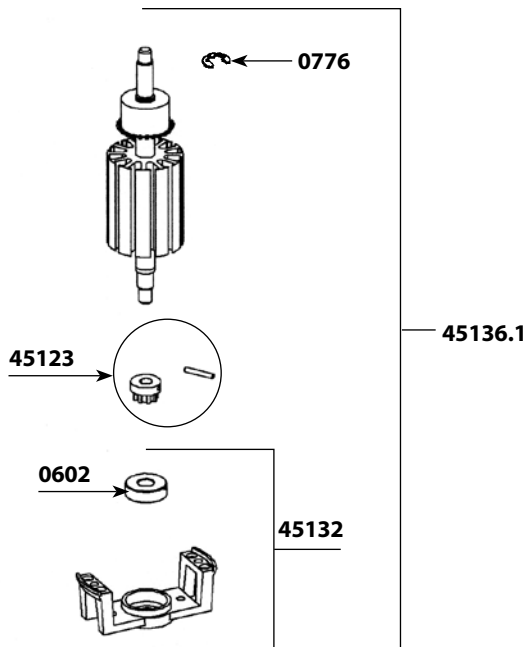

45720

Parts list	Code
Ball bearing	0601
Wall bracket	0862
Strain relief 115 V	0950.1
Shaft & ball bearing	45120 H
Coupling sleeves	45122
Motor & shaft drive sprocket	45123
Removable complete bell	45130 H
Spacer rods (4)	45138 H
Spacer screws (4)	45139
Cutter blade w/ screw	45161
Motor 230 V	45200H
Motor 115 V	45200H.1
Squeezing washer (4)	45230
Top housing	45503
Handle cap (2)	45610H
Circuit board 115 V	45620.1
Top housing (orange plastic piece)	45706
Screws control case set	45706.1
Lower housing (orange plastic piece)	45707
Handle cap protector (unit)	45708
Sleeve & complete handle & label & cap	45709H
Handle cap protector (unit)	45710
Complete control casing 115 V	45712.1
Foot assembly w / lower brearing	45720H
Complete foot assembly	45722H
Power cord 115 V	9040.1

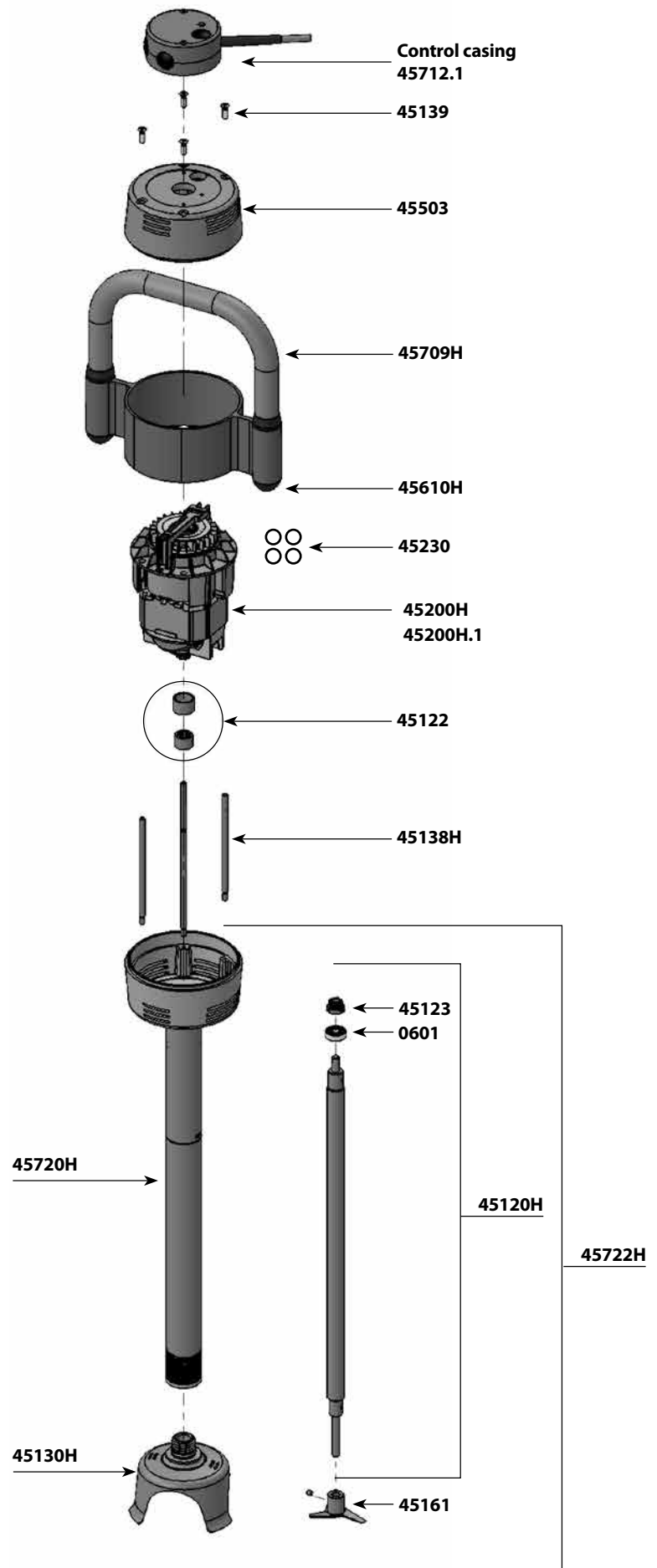
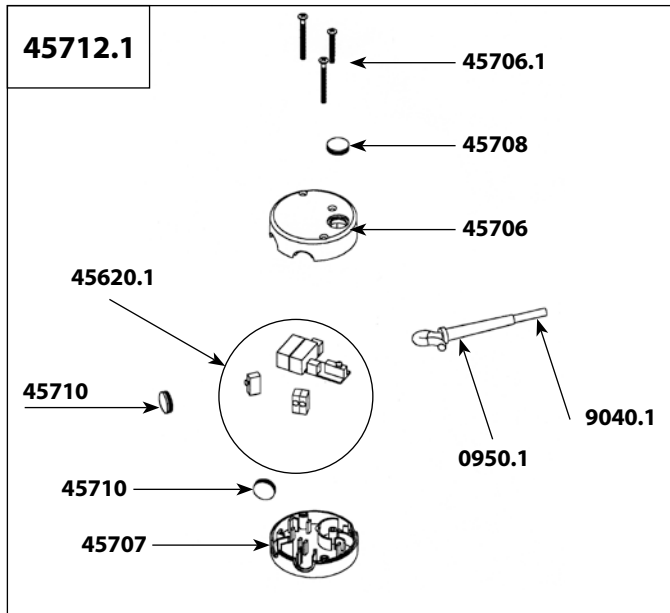
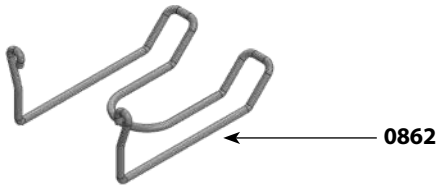

45200H
45200H.1

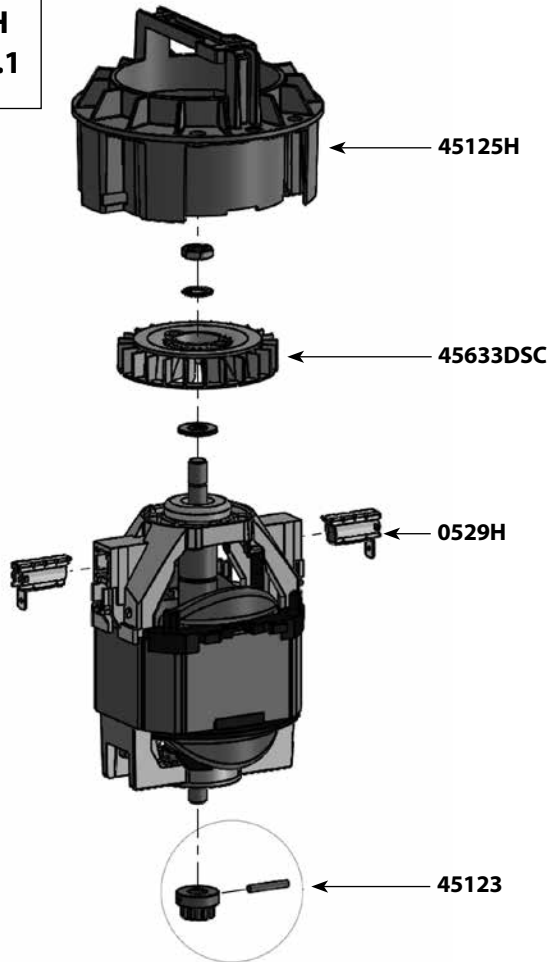

Parts list

Code

Brushes (2)	0529H
Motor & shaft drive sprocket	45123
Fan housing Plastic	45125H
Plastic Fan	45633DSC

45130 H

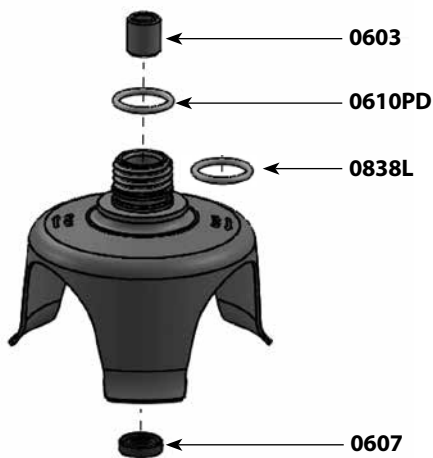

Parts list

Code

Self-lubricating ring	0603
Waterproof seal	0607
O. ring	0610PD
Friction washer	0838L

SMX 600 DSC - 115 V

Parts list	Code
Motor brushes (pair)	0529
Ball bearing	0601
Motor ball bearing	0602
Self-lubricating ring	0603
Waterproof seal	0607
O. ring	0610
Rubber washer	0760
Clips	0776
Washer & bolt for fan	0777
Wall bracket	0862
Strain relief 115 V	0950.1
ID label 115 V	1009
Lower bearing assembly support	1185
Shaft & ball bearing	45120
Coupling sleeves	45122
Motor + drive sprocket	45123
Fan housing Plastic	45125.P
Double isolation plate	45126
Lower bearing assembly	45130
Complete stainless steel lower bearing	45130.1
Brush Holder w/cap (1)	45131.1
Lower motor casing	45132
Upper motor casing	45133
Stator 115 V	45135.1
Rotor 115 V	45136.1
Motor field screws (2)	45137

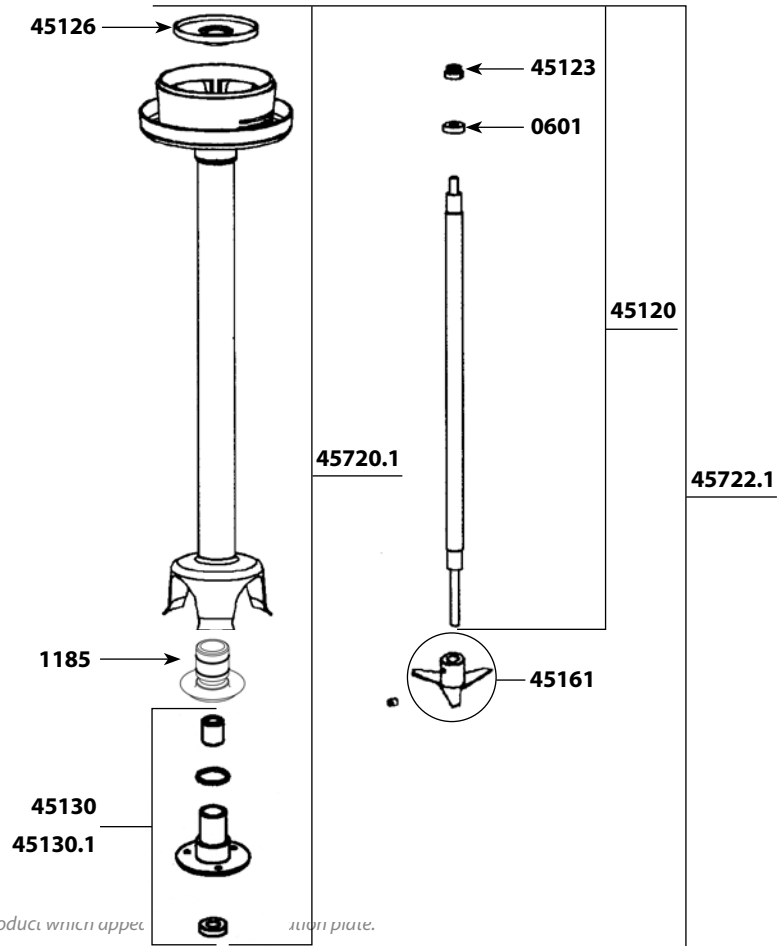
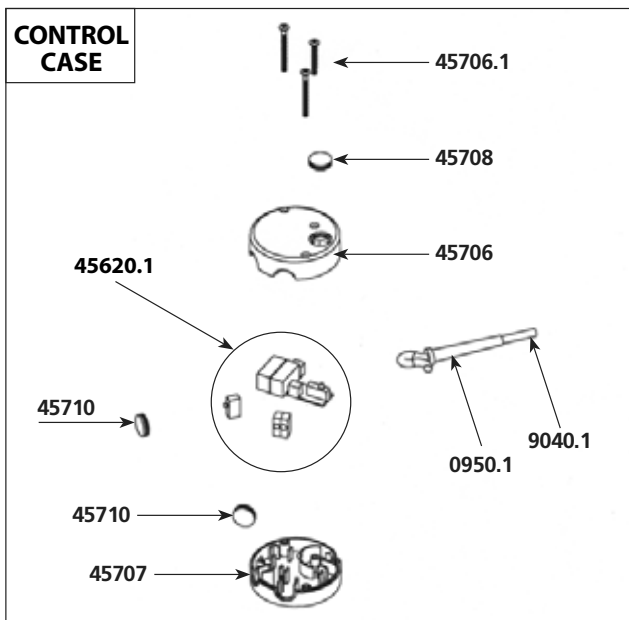
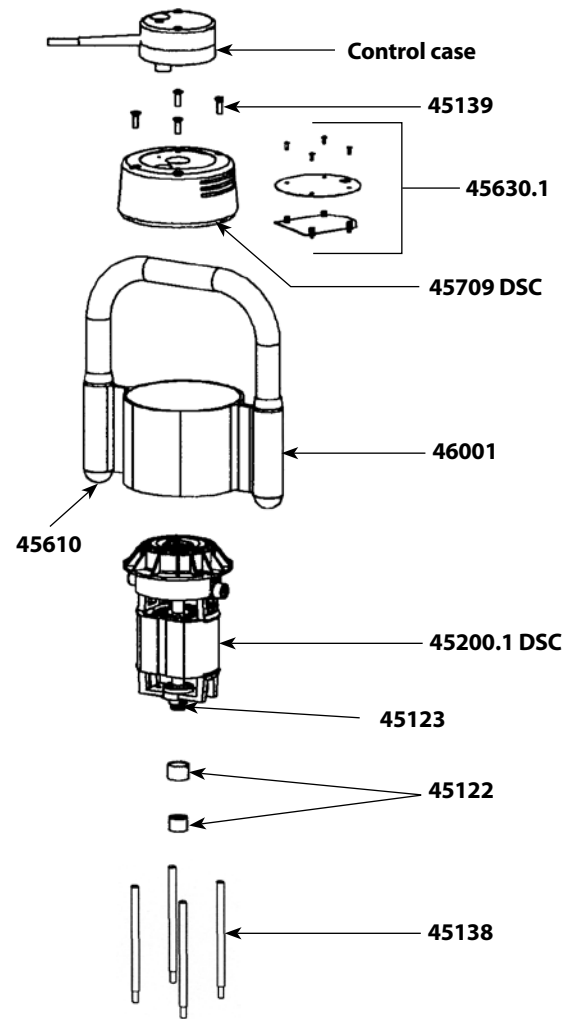

A

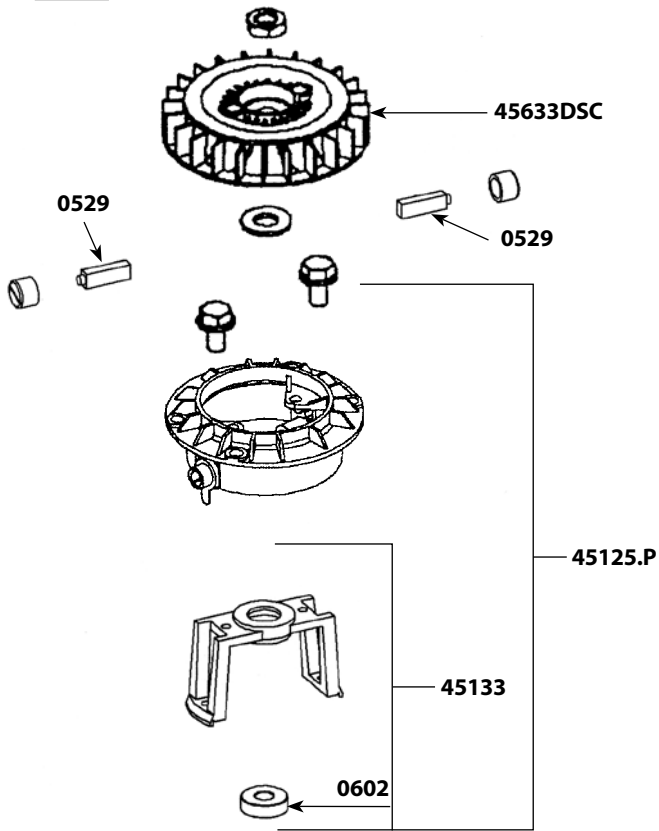

Parts list

Code

Spacer rods (4)	45138
Spacer screws (4)	45139
Cutter blade w/screw	45161
Motor 115 V (complete)	45200.1DSC
Squeezing washer (4)	45230
Sleeve & complete handle & label & cap	45709DSC
Kit w/ shaft, lower bearing, coppler, cutter	45533
Handle cap (2)	45610
Circuit board	45620.1
Regulation circuit board	45630.1
Plastic Fan	45633DSC
Top housing (orange plastic piece)	45706
Screws control case set	45706.1
Orange housing (orange plastic piece)	45707
Lock button rubber cap (unit)	45708
Sleeve + handle + label + stopper	46001
Rubber cap button	45710
Lower housing w/ screws	45711
Foot assembly	45720.1
Complete foot assembly	45722.1
Power cord 115V	9040.1
Lower bearing screws (3)	9902
Stainless steel lower bearing screws (3)	9902.1

B

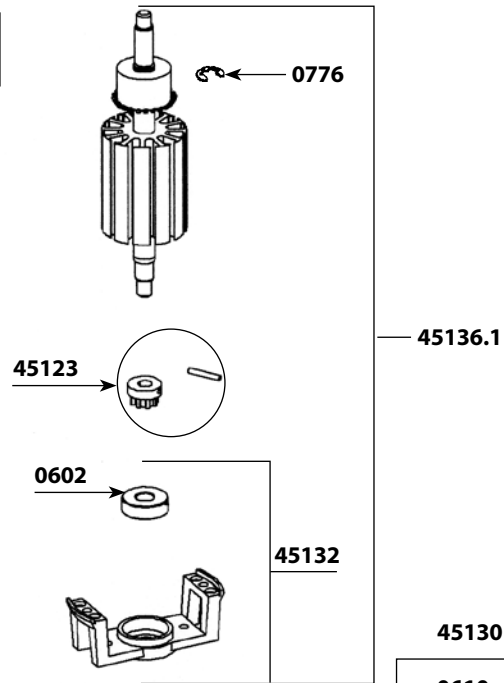

C

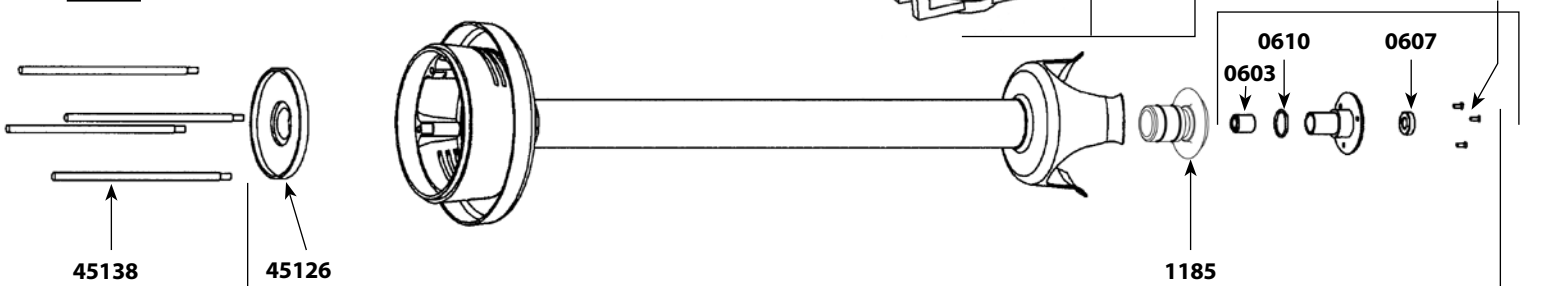

45720.1

Parts list	Code
Carbon brushes (pair)	0529
Ball bearing	0601
Motor ball bearing	0602
Self-lubricating ring	0603
Waterproof seal	0607
O. ring	0610
Toric seal	0641
Rubber washer	0760
Clips	0776
Washer & bolt for fan	0777
Wall bracket	0862
Strain relief 115 V	0950.1
Bearing holder + seal	1185
ID label 115 V	1094
Fan housing Plastic	45125.P
Double isolation plate	45126
Lower bearing assembly	45130
Complete stainless steel lower bearing	45130.1
Brush Holder w/cap (1)	45131
Lower motor casing	45132
Upper motor casing	45133
Stator 115 V	45135.1
Stator screws(2)	45137
Braces (4)	45138
Brace screws (4)	45139
Cutter blade w/ screw	45161
Squeezing washers (4)	45230
Upper motor casing	45503
Handle cap (2)	45610
Circuit board 115 V	45620.1
Foot assembly w/ stainless steel bearing assembly	45631
Shaft & ball bearing	45632
Fan	45633
Complete foot assembly (stainless steel lower bearing)	45635.1
Top housing (orange plastic piece)	45706
Screws control case set	45706.1
Lower housing (orange plastic piece)	45707
Handle cap protector (unit)	45708

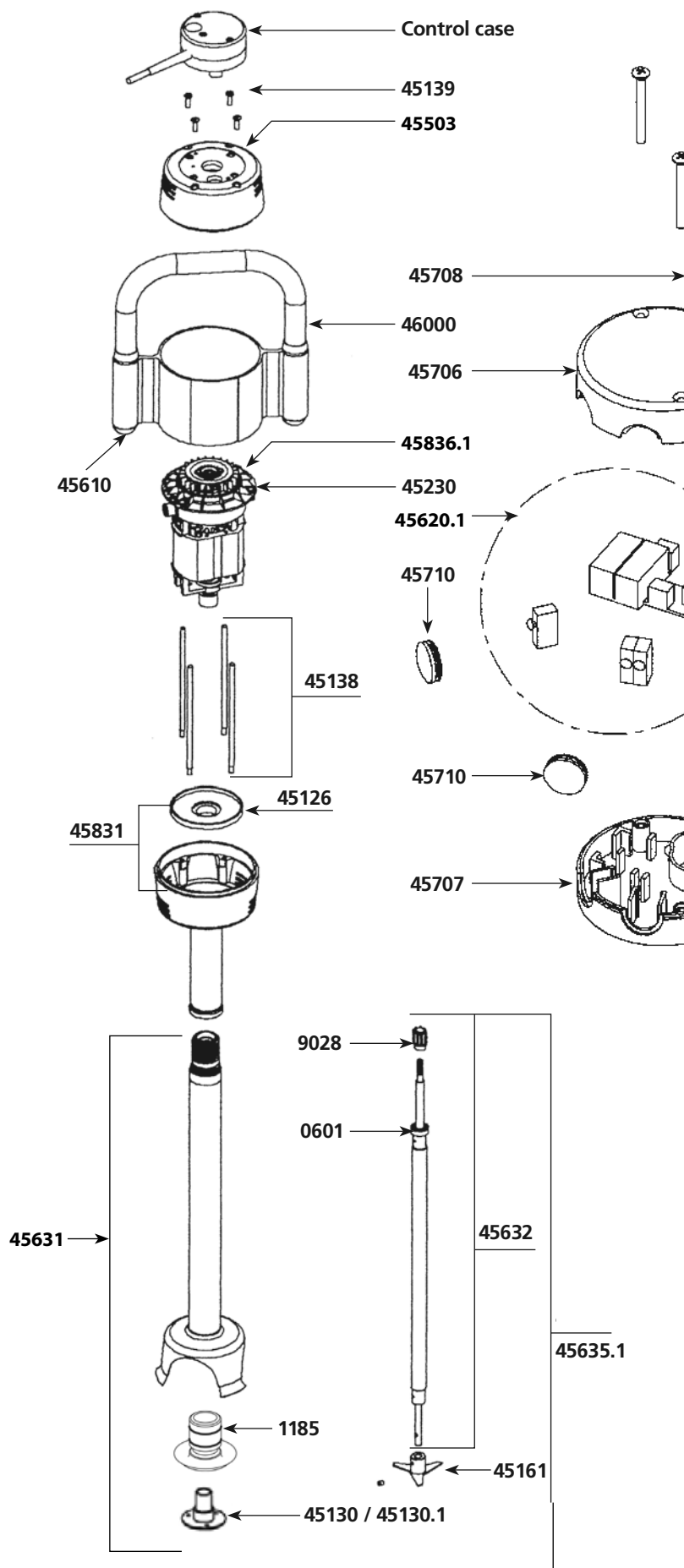

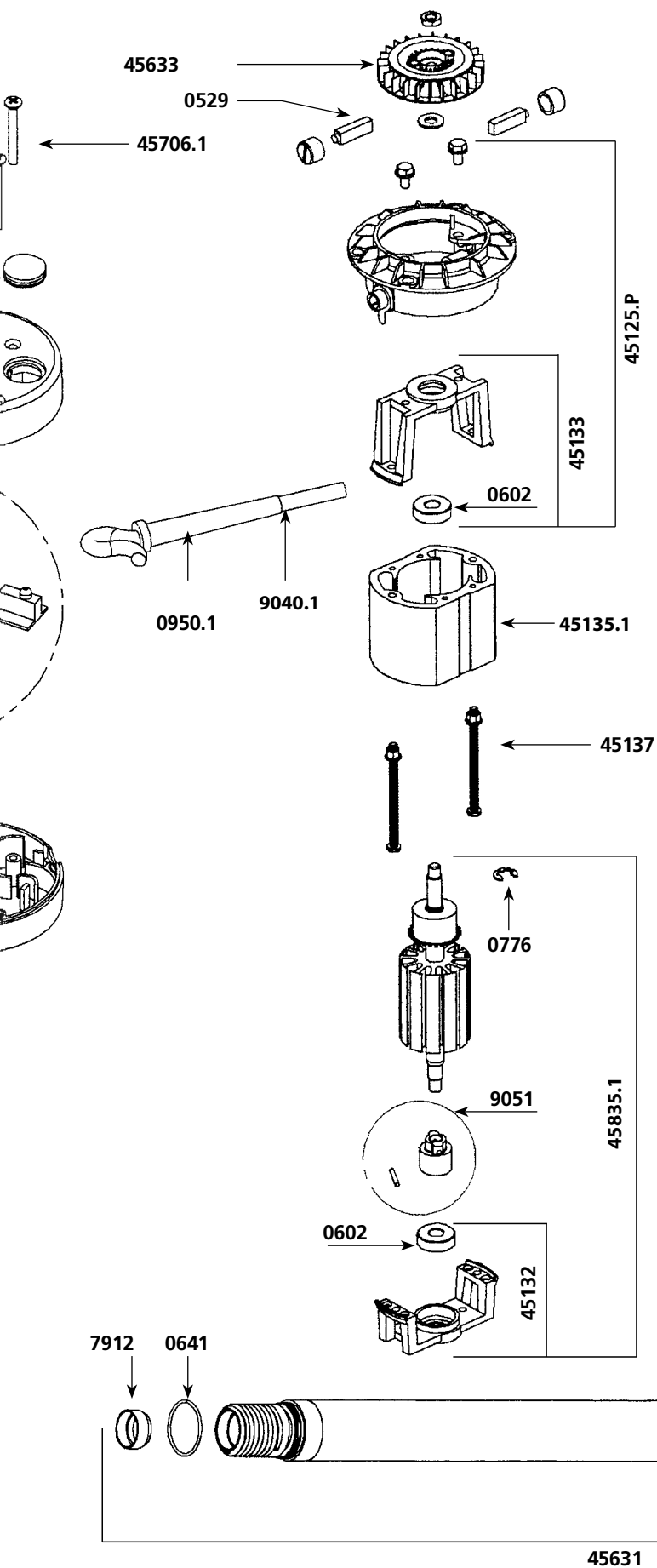

Parts list

Code

Handle cap protector (unit)	45710
Complete housing w/ screws	45711
Lower housing	45831
Rotor 115 V	45835.1
Motor 115 V	45836.1
Sleeve & complete handle & label & cap	46000
Ball bearing ring	7912
Motor & shaft drive sprocket	9028
Power cord 115 V	9040.1
Coupling casing + pin	9051
Lower bearing screws - Stainless steel (3)	9902
Stainless steel lower bearing screws (3)	9902.1

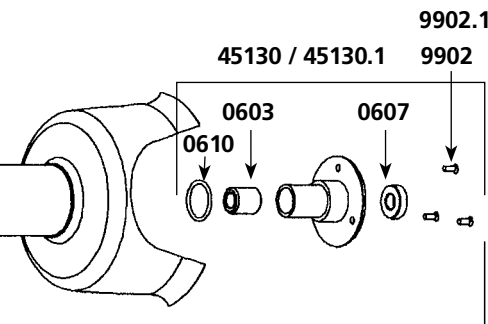
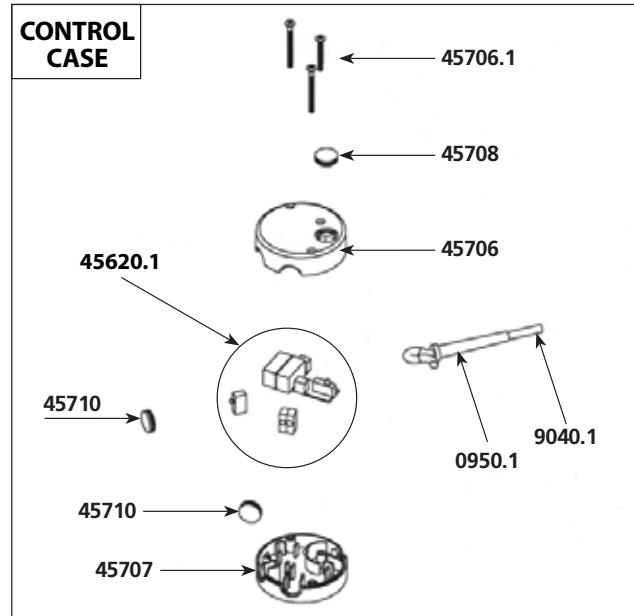

45631

Parts list	Code
Carbon brushes (pair)	0529H
Ball bearing	0601i
Equipped output axle	0807H
Ball bearing ring	119950
Ball bearing ring	119964
Output shaft	45121H
Coupling sleeves	45122
Motor & shaft drive sprocket	45123
Plastic fan housing	45125H
Spacer rods (4)	45138H
Spacer screws (4)	45139
Motor 230 V	45201H
Motor 115 V	45201H.1
Squeezing washer (4)	45230
Top housing	45503
Handle cap (2)	45610H
Plastic Fan	45633 DSC
Sleeve & complete handle & label & cap	45709H
Complete control casing 115V	45712.1
Lower housing	45831H
Motor & shaft drive sprocket	9028

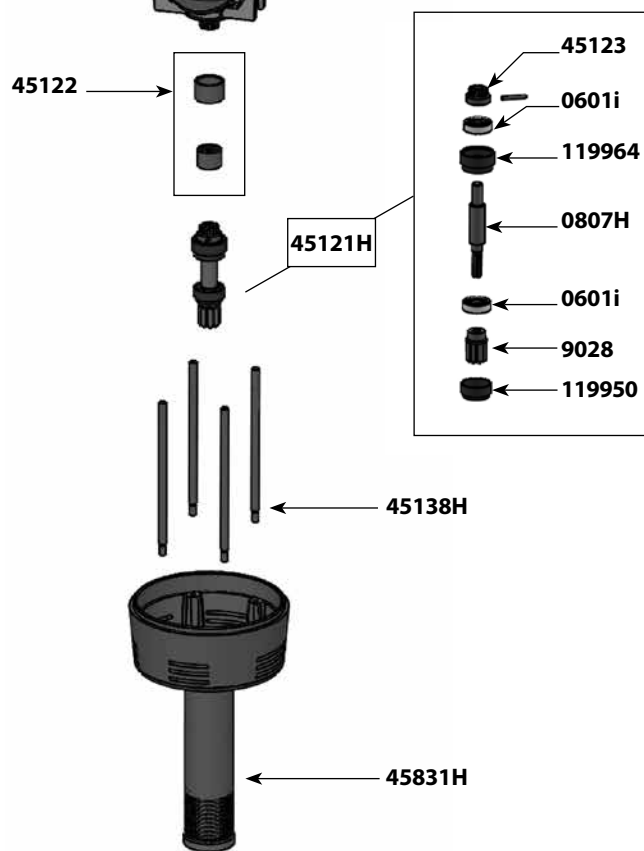
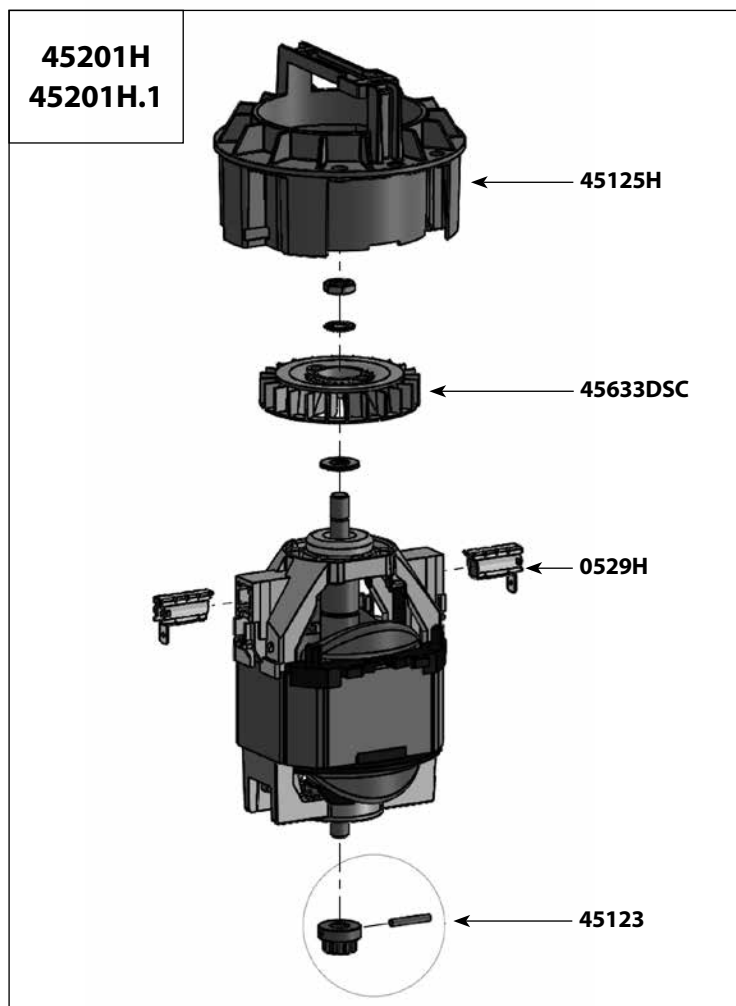
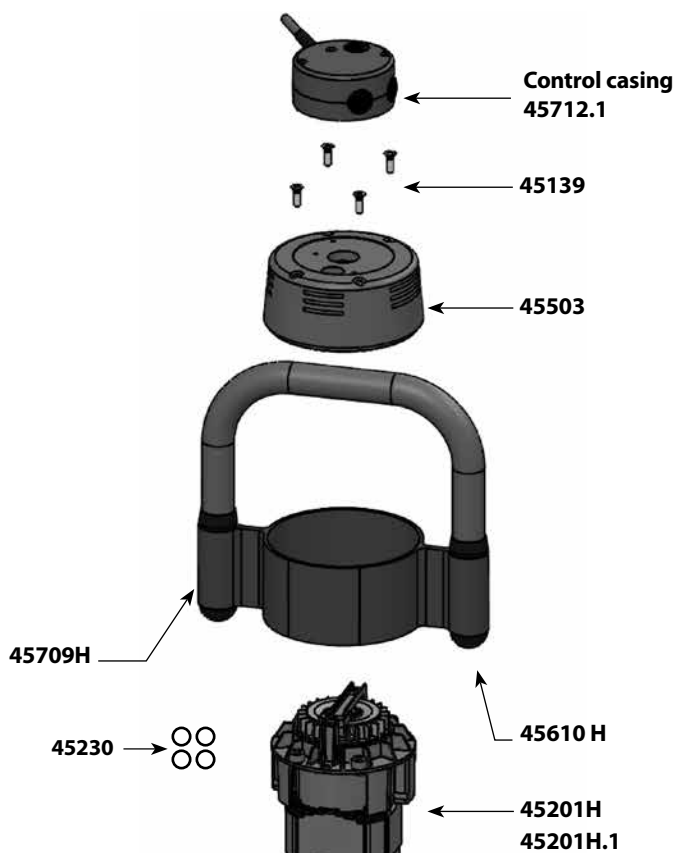

SMX 750 ES Attachment - Ref AC075T
(Complete Attachment)

Parts list

Code

Ball bearing	0601i
Self-lubricating ring	0603
Waterproof seal	0607
O. ring	0610PD
Toric seal	0641
Friction washer	0838L
Wall bracket	0862
Strain relief 115 V	0950.1
Ball bearing ring	7912
Motor & shaft drive sprocket	9028
Power cord 115 V	9040.1
Coupling casing + pin	9051H
Removable complete bell	45130H
Cutter blade w/ screw	45161
Shaft & bearing	45328
Foot assembly	45329
Circuit board 115V	45620.1
Top housing (orange plastic piece)	45706
Screws control case set	45706.1
Lower housing (orange plastic piece)	45707
Handle cap protector (unit)	45708
Handle cap protector (unit)	45710

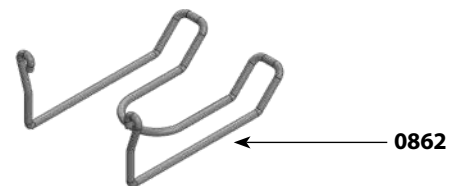
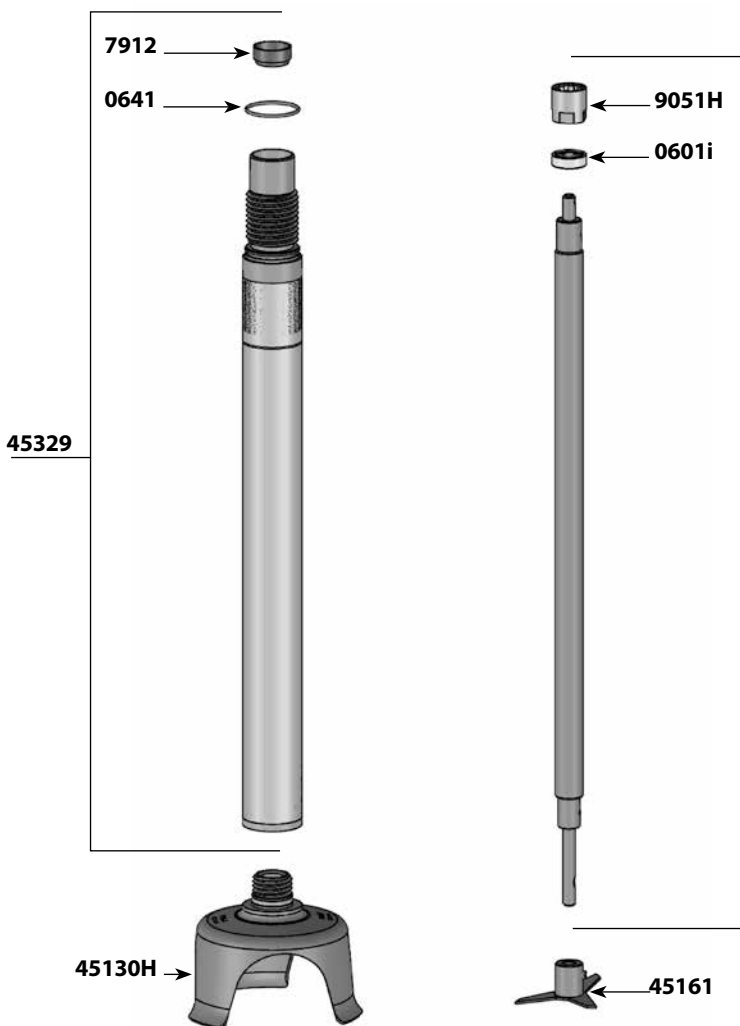
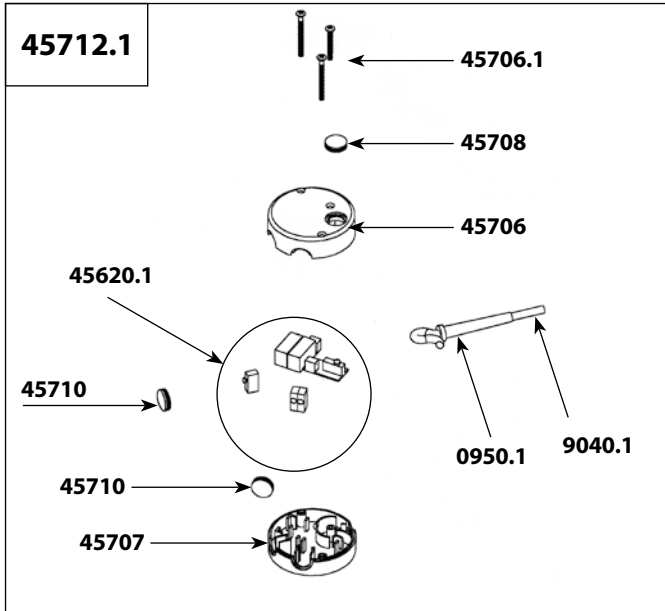

45328

45130 H

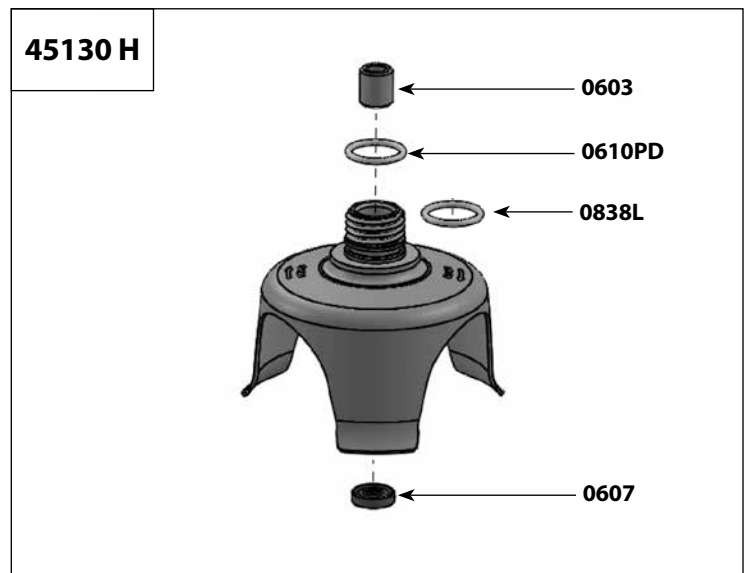

Parts list	Code
Aluminium Fan	0509
Motor brushes (pair)	0529
Ball bearing	0601
Motor ball bearing	0602
Self-lubricating ring	0603
Waterproof seal	0607
O. ring	0610
Toric seal	0641
Rubber washer	0760
Clips	0776
Washer & bolt for fan	0777
Wall bracket	0862
Strain relief 115 V	0950.1
ID label 115 V	1074
Lower bearing assembly support	1185
Fan housing Plastic	45125.P
Double isolation plate	45126
Lower bearing assembly	45130
Complete stainless steel lower bearing	45130.1
Brush Holder w/cap (1)	45131
Lower motor casing	45132
Upper motor casing	45133
Stator 115 V	45135.1
Stator screws(2)	45137
Spacer rods (4)	45138
Spacer screws (4)	45139
Cutter blade w/screw	45161
Squeezing washer (4)	45230
Top housing	45503
Handle cap (2)	45610
Circuit board 115 V	45620.1

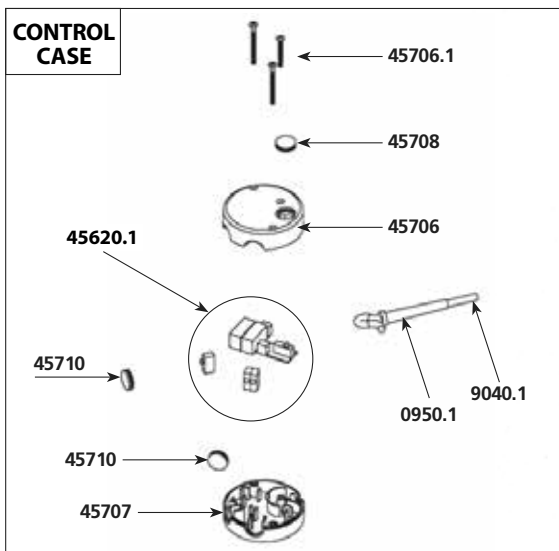
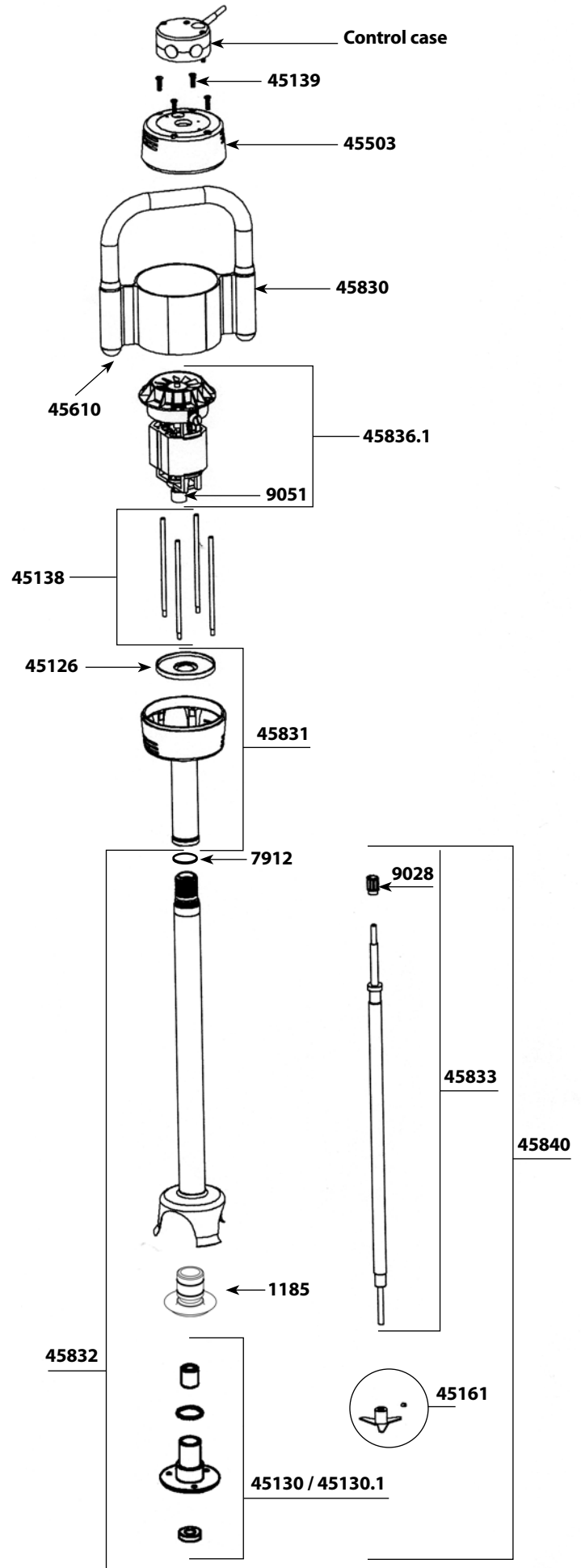

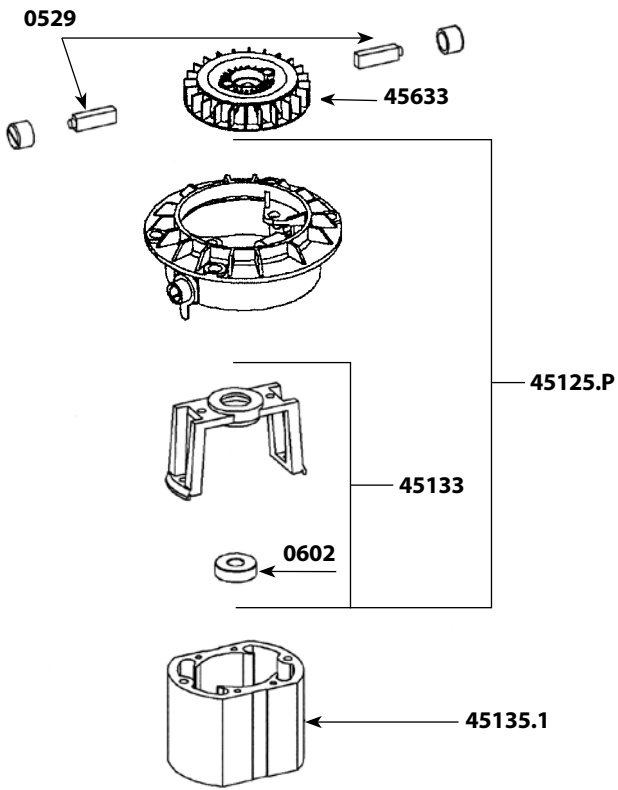

Parts list	Code
Plastic fan	45633
Top housing (orange plastic piece)	45706
Screws control case set	45706.1
Lower housing (orange plastic piece)	45707
Lock button rubber cap (unit)	45708
Handle cap protector (unit)	45710
Orange housing w/ screws	45711
Sleeve & complete handle & label & cap	45830
Lower housing (aluminum)	45831
Foot assembly w/ bearing assembly	45832
Shaft, ball bearing + coupler	45833
Kit w/ shaft, lower bearing, coupler, cutter	45834
Rotor 115 V	45835.1
Motor 115 V (complete)	45836.1
Complete foot assembly	45840
Ball bearing sleeve	7912
Coupler for shaft	9028
Power cord (115v)	9040.1
Coupling casing + pin	9051
Lower bearing screws (3)	9902
Stainless steel lower bearing screws (3)	9902.1

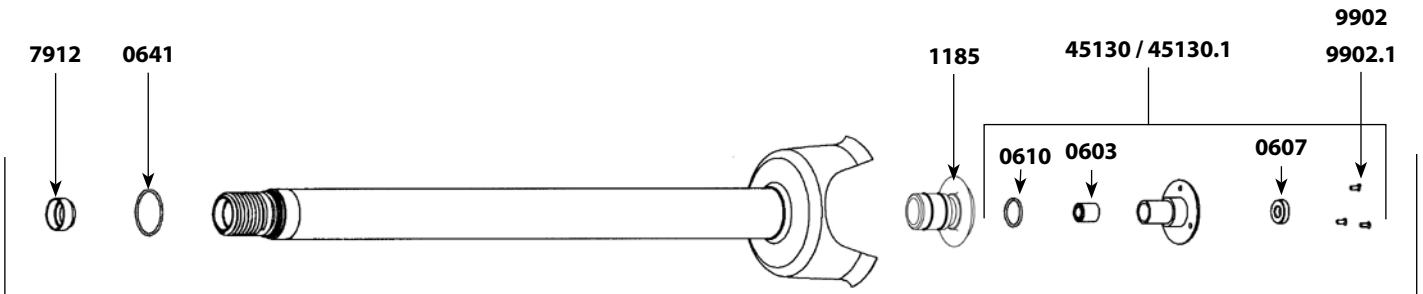
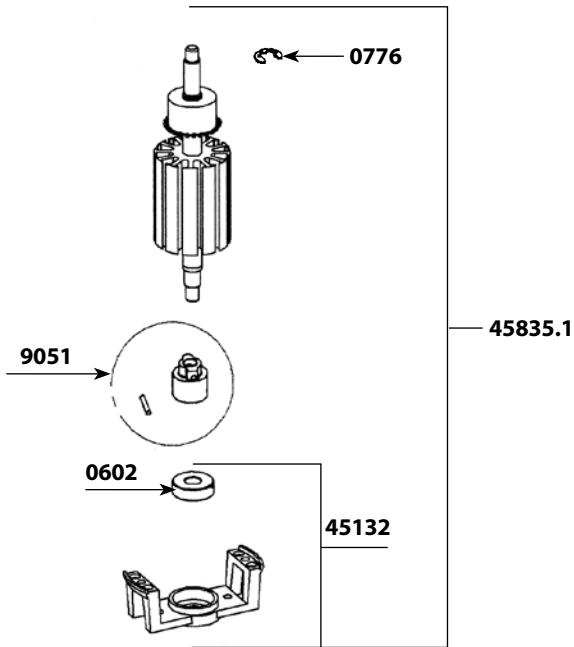

45832

SMX 800 DSC - 115 V

Parts list	Code
Motor brushes (pair)	0529
Ball bearing	0601
Motor ball bearing	0602
Self-lubricating ring	0603
Waterproof seal	0607
O. ring	0610
Toric seal	0641
Rubber washer	0760
Clips	0776
Washer & bolt for fan	0777
Wall bracket	0862
Strain relief 115 V	0950.1
ID label 115V	1099
Lower bearing assembly support	1185
Fan housing Plastic	45125.P
Double isolation plate	45126
Lower bearing assembly	45130
Complete stainless steel lower bearing	45130.1
Brush Holder w/cap (1)	45131.1
Lower motor casing	45132
Upper motor casing	45133
Stator 115 V	45135.1
Motor field screws (4)	45137
Spacer rods (4)	45138
Spacer screws (4)	45139
Cutter blade w/screw	45161
Squeezing washers (4)	45230
Top housing	45503DSC
Handle cap (2)	45610
Circuit board	45620.1
Regulation circuit board	45630.1
Fan (DSC)	45633DSC
Top housing (orange plastic piece)	45706
Screws control case set	45706.1
Lower housing (orange plastic piece)	45707
Lock button rubber cap (unit)	45708
Rubber button cap	45710

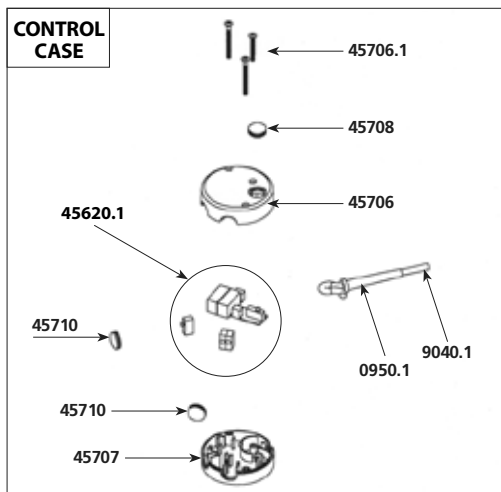
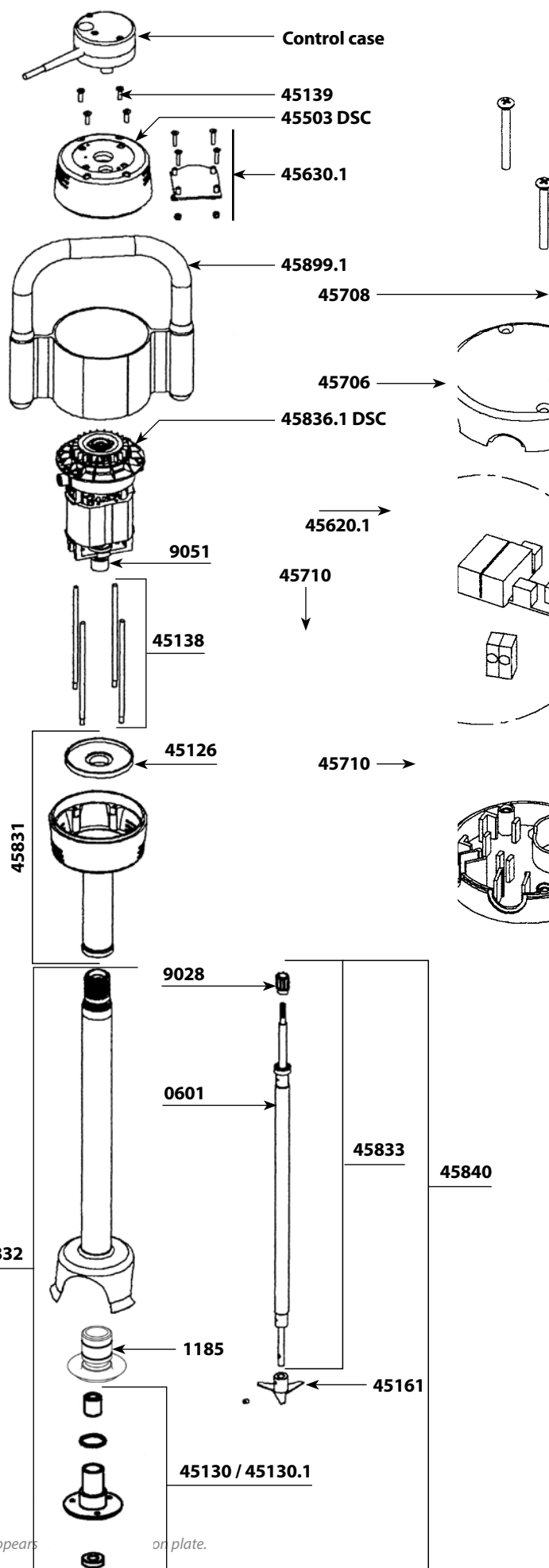

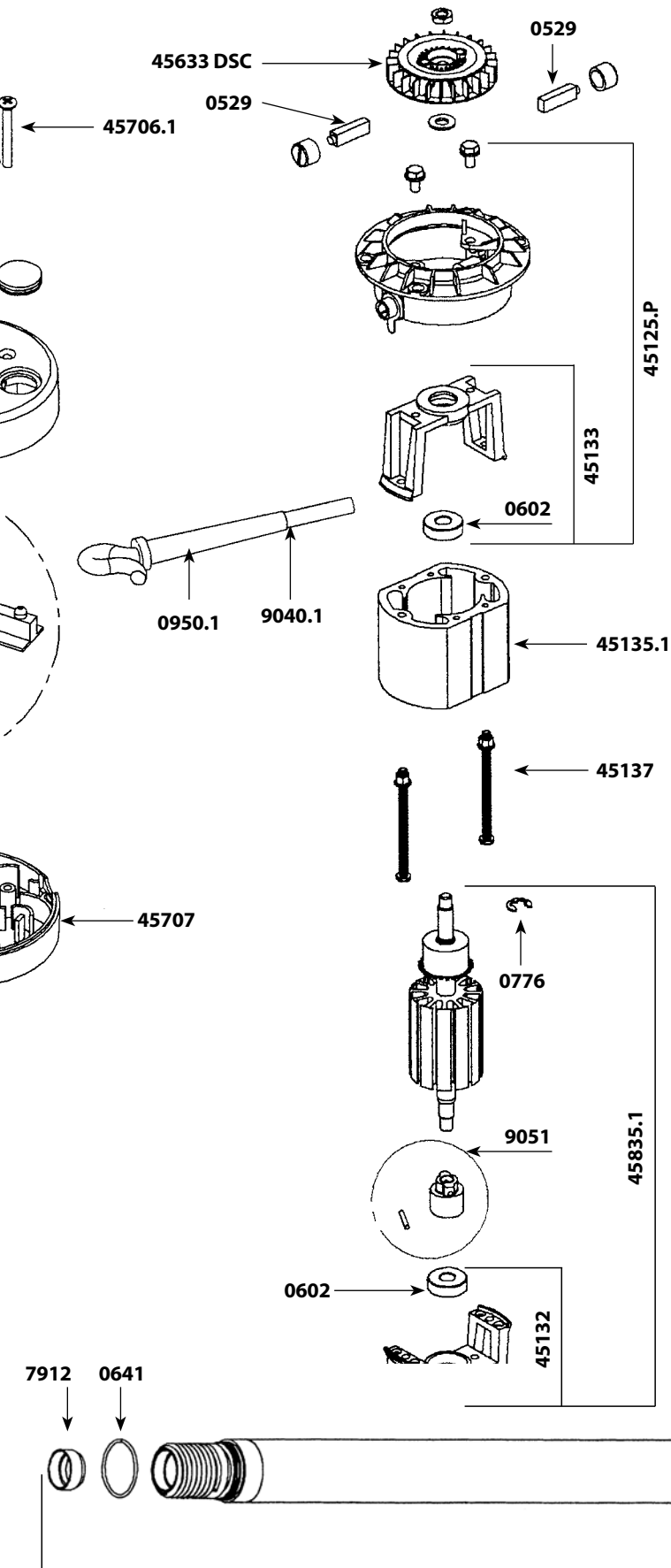

Parts list

Code

Orange housing w/ screws	45711
Lower housing	45831
Foot assembly w/ bearing assembly	45832
Shaft & ball bearing	45833
Kit w/ shaft, lower bearing, coupler, cutter	45834
Rotor 115 V	45835.1
Motor 115 V (complete)	45836.1DSC
Complete foot assembly	45840
Sleeve + handle + label + stopper	45899.1
Ball bearing sleeve	7912
Coupler for shaft	9028
Power cord 115 V	9040.1
Coupling casing + pin	9051
Lower bearing screws (3)	9902
Stainless steel lower bearing screws (3)	9902.1

45832

Parts list	Code
Carbon brushes (pair)	0529H
Ball bearing	0601i
Equipped output axle	0807H
Ball bearing ring	119950
Ball bearing ring	119964
Output shaft	45121H
Coupling sleeves	45122
Motor & shaft drive sprocket	45123
Fan housing Plastic	45125H
Spacer rods (4)	45138H
Spacer screws (4)	45139
Motor 230 V	45202H
Motor 115 V	45202H.1
Squeezing washer (4)	45230
Top housing	45503
Handle cap (2)	45610H
Plastic Fan	45633DSC
Sleeve & complete handle & label & cap	45709H
Complete control casing 115V	45712.1
Lower housing	45831H

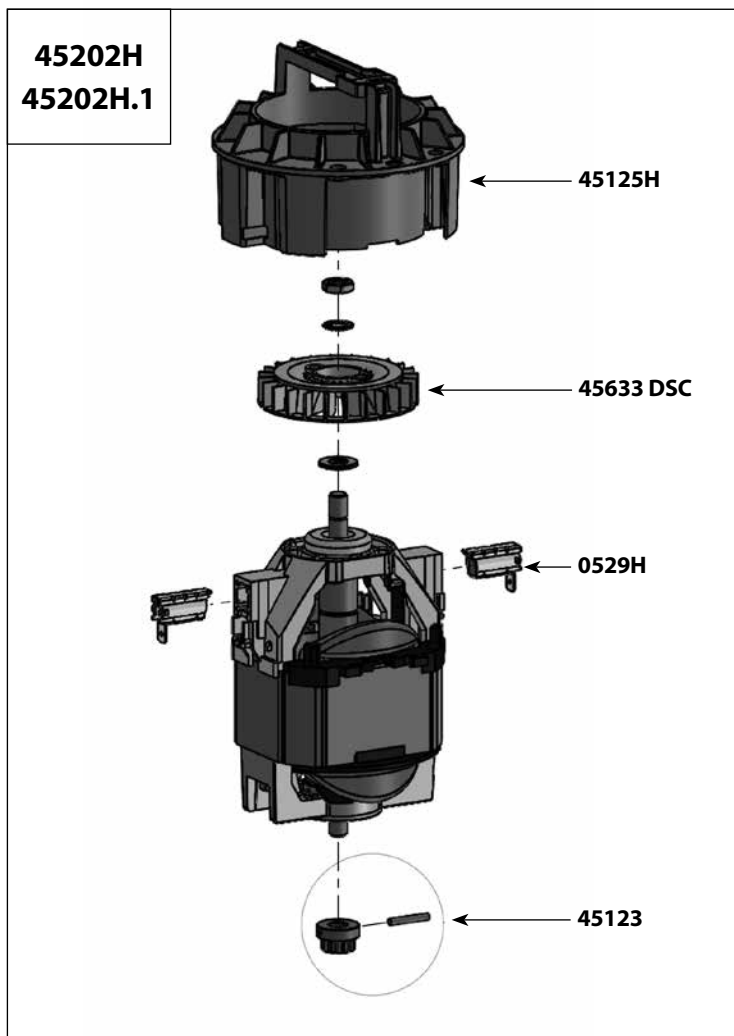
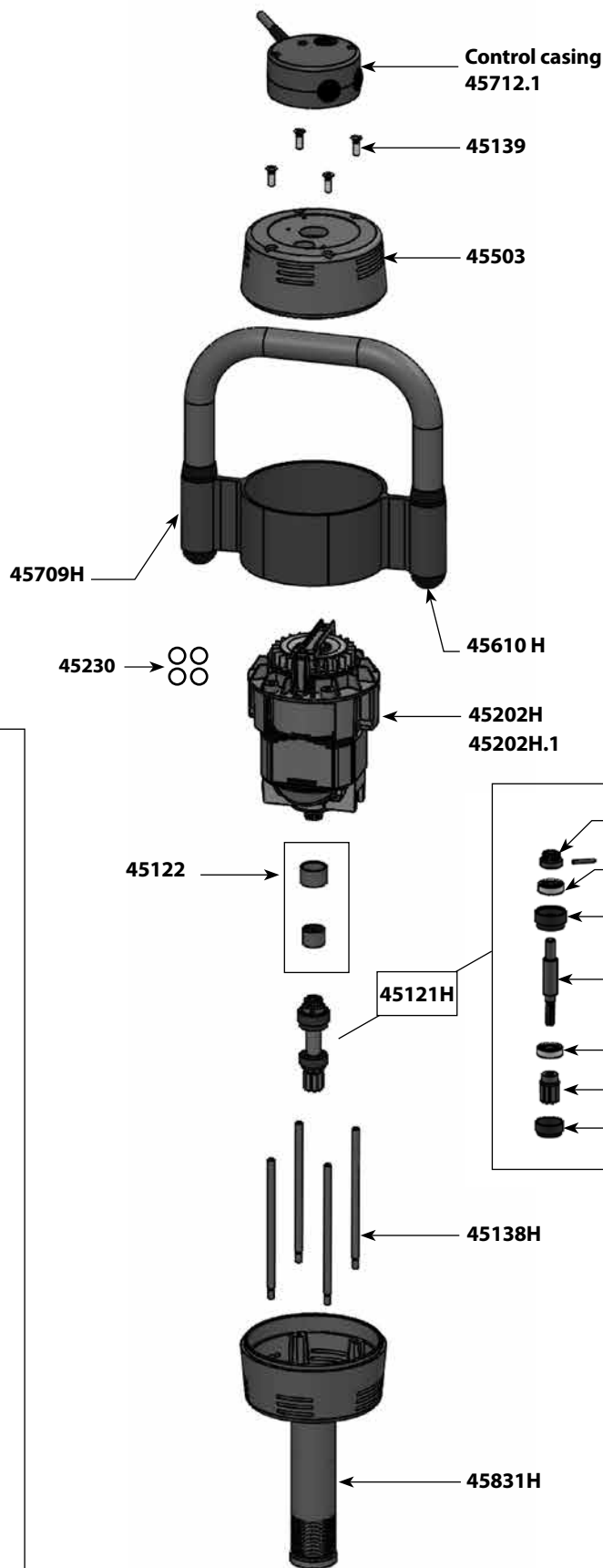

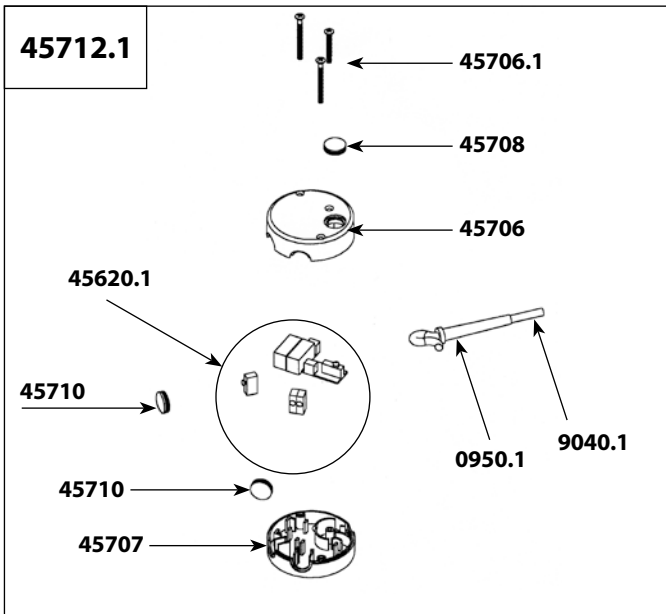

SMX 850 ES Attachment - Ref AC076T
(Complete Attachment)

Parts list	Code
Ball bearing	0601i
Self-lubricating ring	0603
Waterproof seal	0607
O. ring	0610PD
Toric seal	0641
Friction washer	0838L
Wall bracket	0862
Strain relief 115V	0950.1
Ball bearing ring	7912
Motor & shaft drive sprocket	9028
Power cord 115V	9040.1
Coupling casing + pin	9051H
Removable complete bell	45130H
Cutter blade w/ screw	45161
Shaft & bearing	45324
Foot assembly	45325
Circuit board 115V	45620.1
Top housing (orange plastic piece)	45706
Screws control case set	45706.1
Lower housing (orange plastic piece)	45707
Handle cap protector (unit)	45708
Handle cap protector (unit)	45710

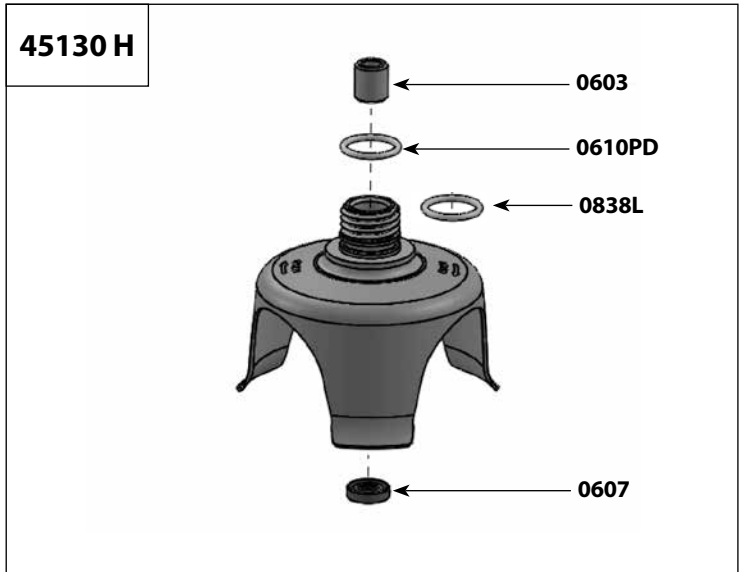
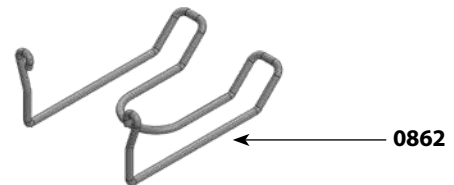

SMX BLENDER

Parts list	Code
O. ring	0641
Self-lubricating ring	0666
Waterproof seal	0667
Blender bell	1412
Blender hammer	1413
Blender key	1445
Plastic sleeve	7912
Coupler for armature	9028
Shaft	45326
Foot assembly	45327
Ball bearing	0601i
Coupler for armature	9051H

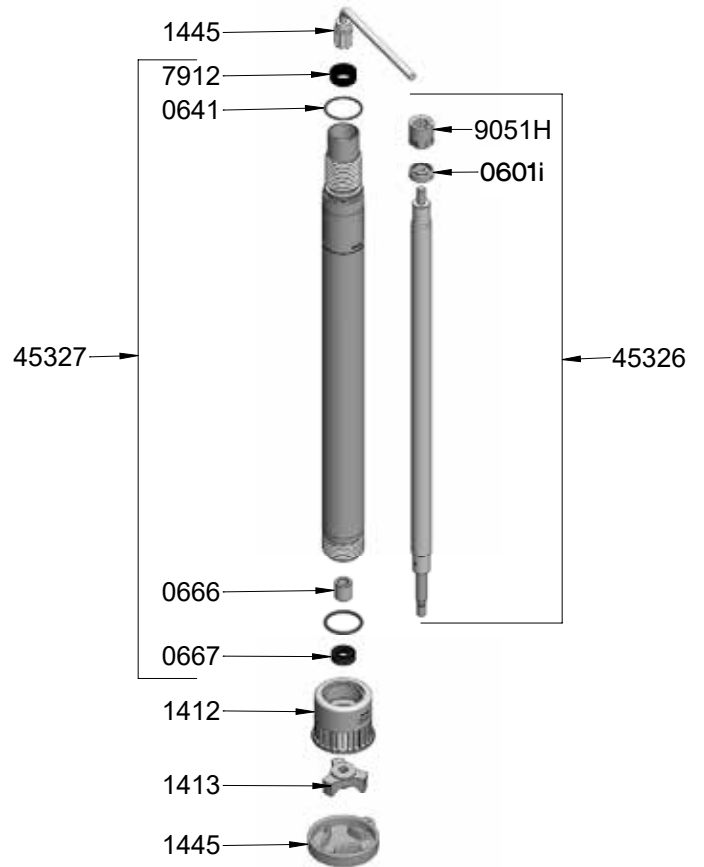

Parts list

Code

Jib assembling..... 9346

Transmission belt	0625
Front jib cap	0786
Back jib cap	0786P
Cover	089915
Directing pulley + hub	9362
Conducting pulley + hub	9363
Screw set + washers for fixing the motor	9364
Screw set + washers for fixing the jib	9365
Screw set + washers for fixing the axle-brake	9366
Screw set + washers for fixing the tube	9367
Screw set + washers for fixing the cover	9368
Motor	9369
Screw set + nuts for fixing the steel sheet on the jib	9370
Screw set for fixing the steel sheet on the motor housing	9371

Parts list

Code

Electrical Box

Box case + pe	9390
Stainless steel box + pe	9390.1
Motor connector	9391
Phased 2.2kw variator	9392
Connection terminal	9393
Stop push button	9394
"Emergency stop" button	9395
On/off light	9396
"On/off" push button	9397
Potentiometer + push button	9398
PE DEI DSI button	9399
Thermal relay	93991

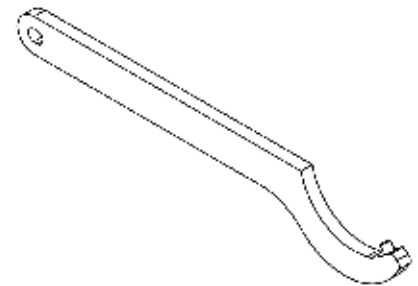
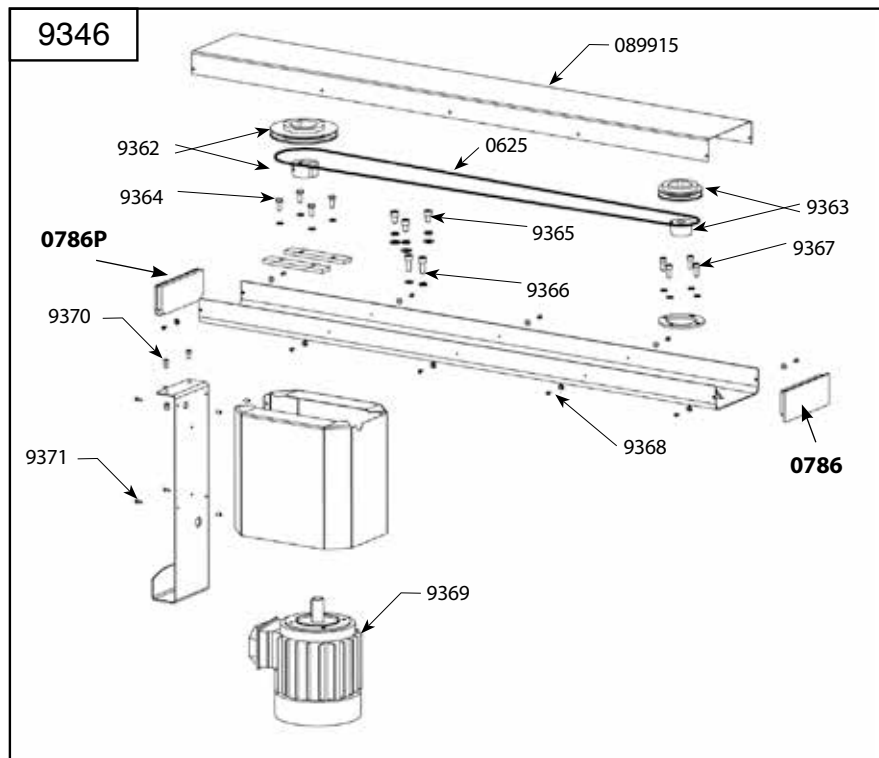

Parts list	Code	List \$ Price
Spanner wrench	9388	243.19

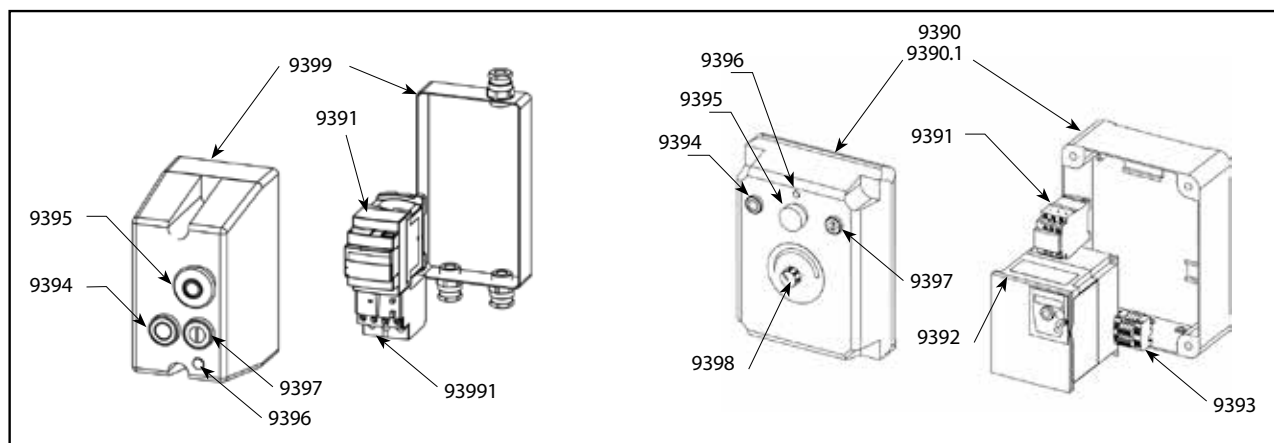

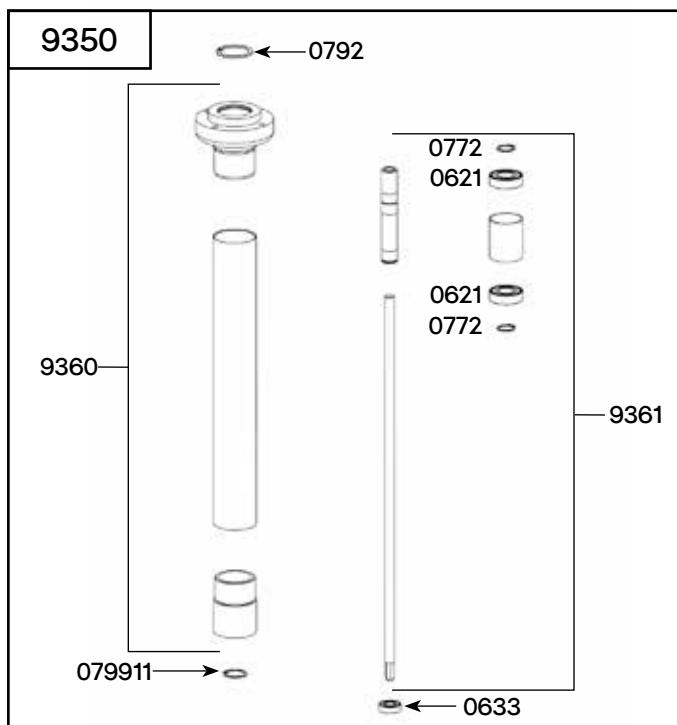

Parts list **Code**
Foot attachment assembling.....9350

Ball bearing (unit)	0621
Ball bearing	0633
Clips (2)	0772
Rubber ring for upper bearing holder	0792
Rubber ring case	079911
Bearing holder, brace, case	9360
Drive shaft	9361

Detachable bell assembling TB012

Toric joint 30 x 3	0618
Toric joint 42 x 2.5	0639
Toric joint 34 x 2	0640
Ball bearing	0649
Waterproof lip seal	0662
Open head locking washer	0790
Lower bearing	089912
Seal support	089926
Waterproofness set (seal + ball bearing + screws + open head locking washer)	9349
Blade	9356
Lower shaft + bearing+coupling + clips	9357
Protection bell	9358
Assembling set of screw for the bell	9359

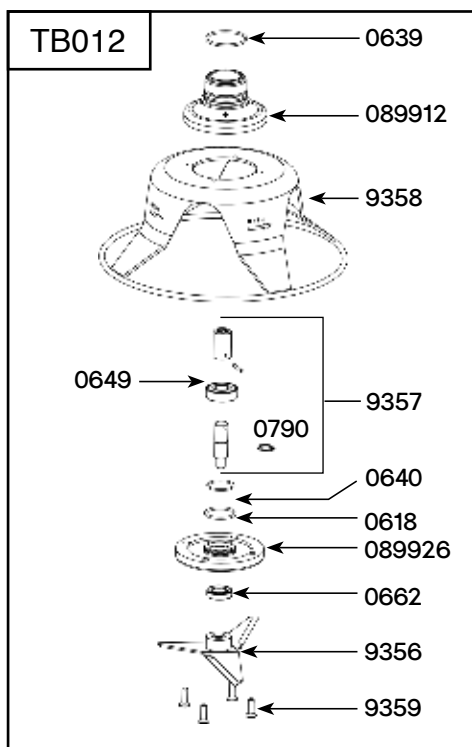

Detachable blender assemblingTB 004

Toric joint	0639
Ball bearing	0649
Waterproof seal	0665
Elastic ring 15	0790
Elastic ring 35	079977
Hammer	0899920
BLENDER POWER PRO bell	0899921
Waterproof set (seal + bearing + screw + clips)	9348
Lower shaft + bearing + coupling + clips	9357

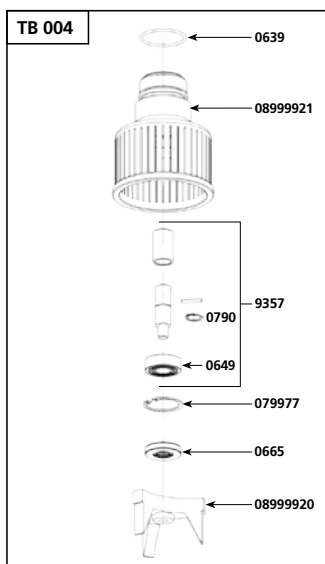

Parts list

Code

Pin-brake assembling..... 9352

Plain screw M8x30	0773
Rubber ring for brake thrust	0788
Compression spring	0789
Rubber ring for brake axle	0791
Handle for brake	079912
Insulating sheet	089916
Brake thrust	089921
Interpolated sheet	089927
Jib plate holder	089932
Handle	9077
Handle screws	9078
Brake axle	9372
Microswitch + screws	9373
Pin-brake + eccentric + cam + cam axle	9374

Parts list

Code

Additional parts

Detachable handle	0793
Ring 50x12	089953
Fixed wheel + screws (unit)	9353
Brake wheel + screws (unit)	9354
Frame + jib holder	9355

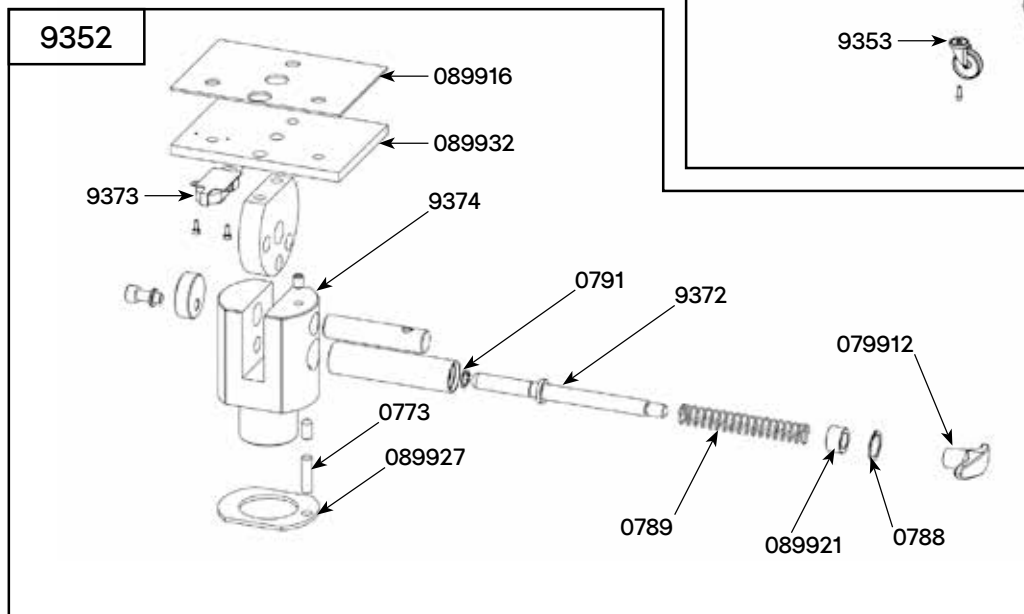
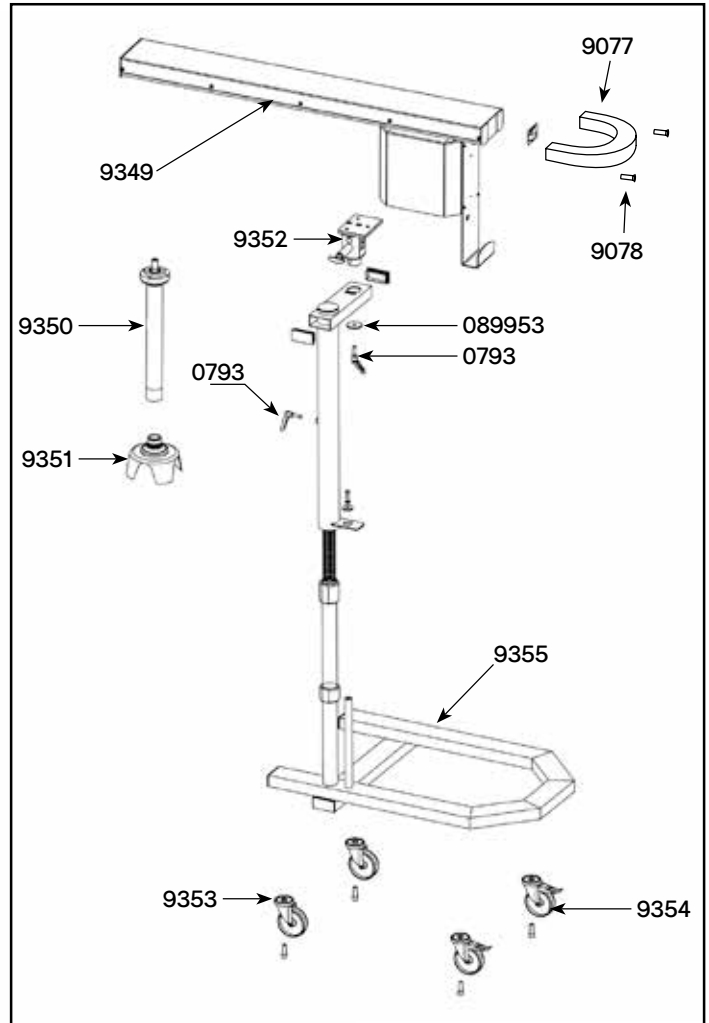

9387

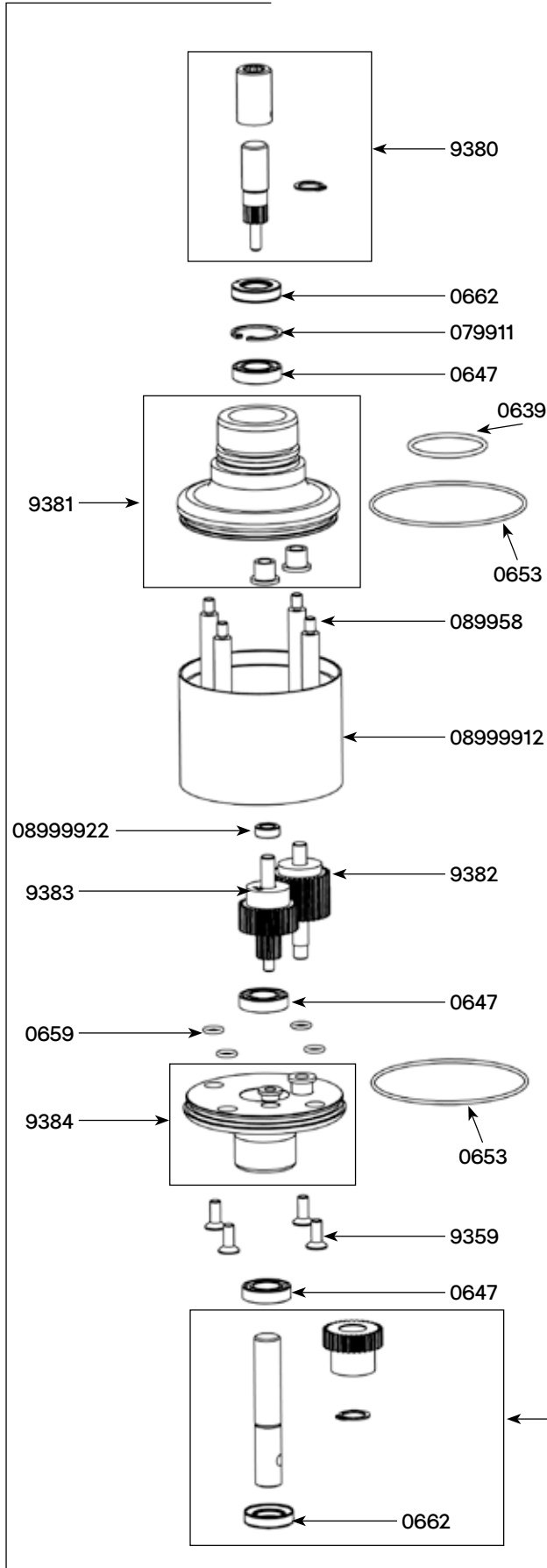

Parts list

Code

Beater whisk assembling

Toric seal 42 x 2.5	0639
Ball bearing	0647
Toric seal 86 x 2	0653
Toric seal 8 x 1.9 (1)	0659
Ring	0662
Clip	079911
Spacer rod (1)	089958
Tube	0899912
Tube middle gear	0899922
Screws M6 (4)	9359
Equipped upper shaft	9380
Lower bearing + rings	9381
Equipped output axle w/ 2 gears	9382
Middle gear and shaft	9383
Reduction case holder + rings	9384
Output axle	9385
Whisk tool	9386
Complete reduction casing without whip	9387

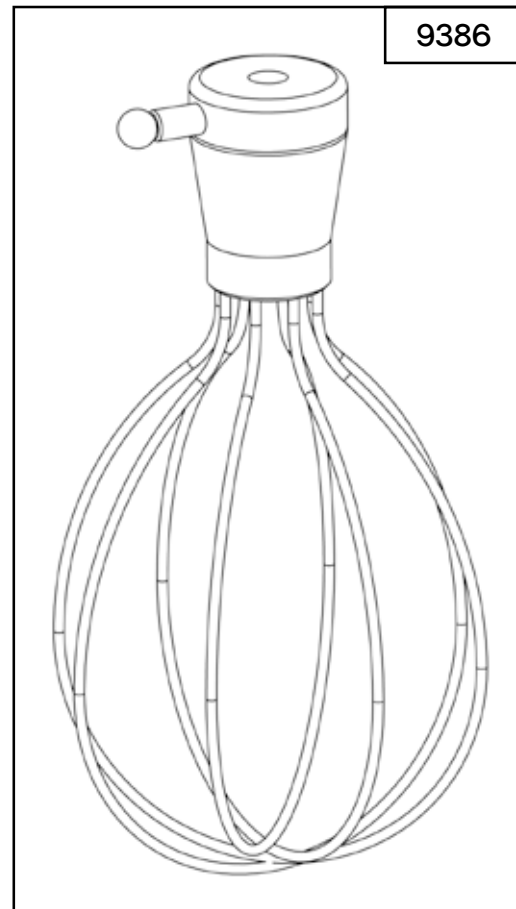

Parts list Code

Ball bearing	0633
Toric joint 42 x 2.5	0639
Rubber ring for brake axle	0791
Rubber ring case	079911
Drive shaft	9334
Brace and case	9335

DYNAPUMP - Ref TB030

Parts list Code

Right half clamp	08999930
Left half clamp	08999931
3/4 Stainless male cap	08999932
3/4 Stainless female reducer	08999933
Pump hinge	08999935
3/4 Male fitting	08999936
Hose nipple camlock fittings DN19	08999937
3/4 Hose nipple threaded connection	08999939
25-35 Hose clamp	08999940
Pump distribution gun	08999941
Pump locker + washer + butterfly nut	9347
Gigamix Gun (see machine catalog)	TB040
Hose pipe (2,5 cm)	TB045
Hose pipe with cam axle	TB046

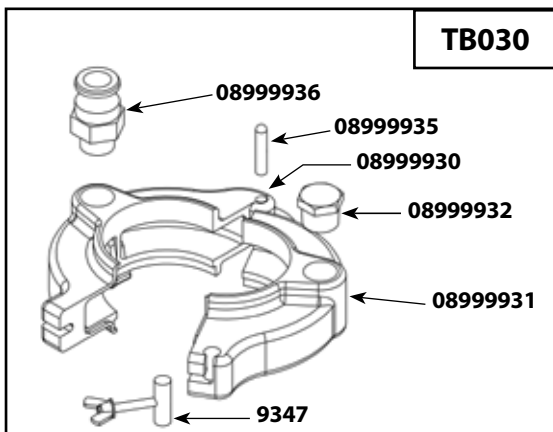
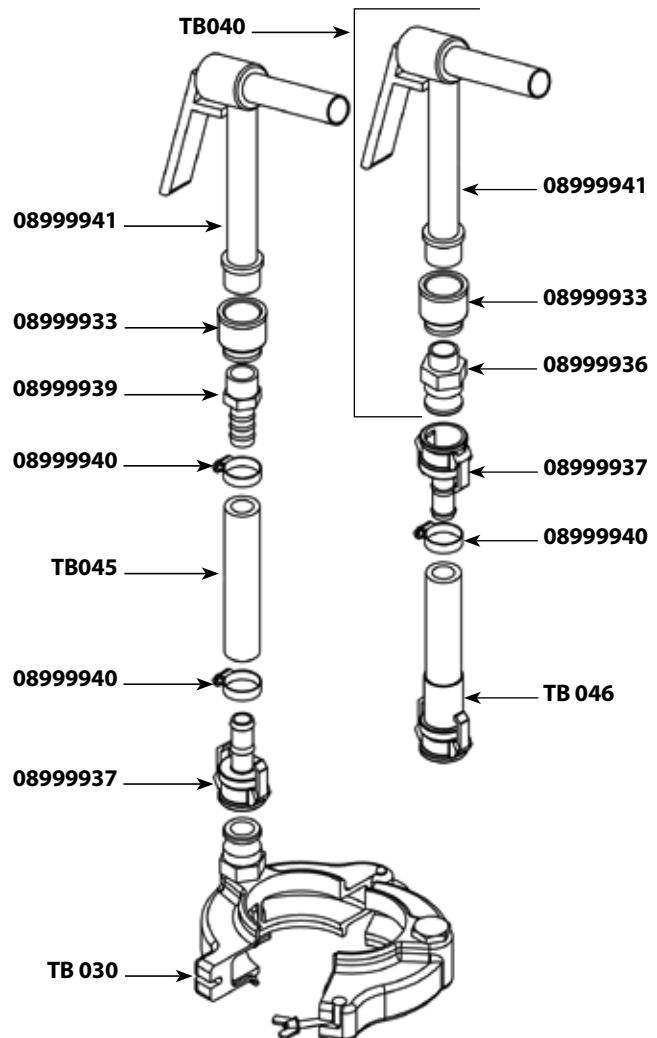
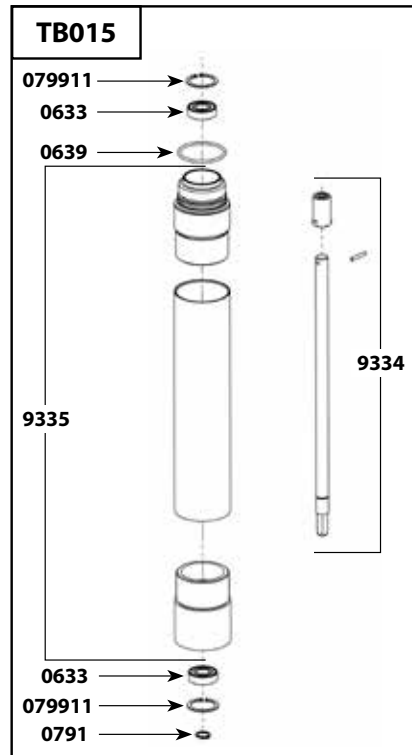

PA 96 CITRUS JUICER - DYNAJUICER

Parts list	Code
Pulp filter	0420
Base screws (3)	0702
Pad	0748
Motor screw (1)	079929
Strain relief 230 V	0950
Strain relief 115V	0950.1
Switch	0998
Switch from N°70037	0998.1
Motor holder + waterproof ring	9601
Power cord 230 V	9602
Power cord 115 V	9602.1
Power cord (UK)	9602.2
Power cord (Australian)	9602.3
Motor w/ capacitor & shaft 230 V	9603
Motor + capacitor + shaft 115 V (*new smaller motor from N°1700046; check serial number)	9603.1
Upper ring	9604
Top orange container	9605
Centrifuge cone	9606
Base	9607
Centrifuge cone (small)	9608

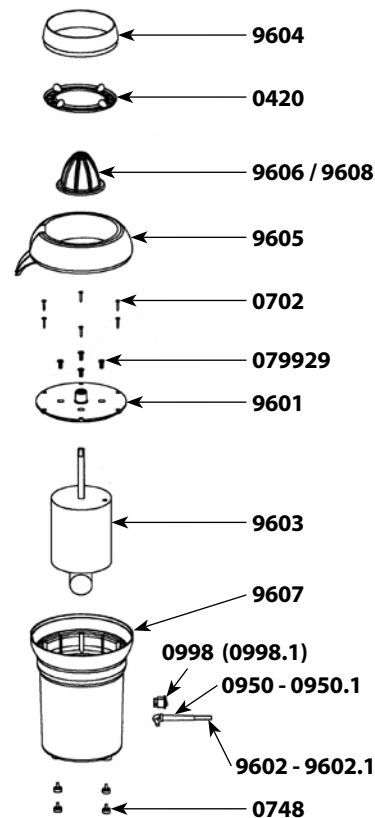

SM 4/6/8/10/12 MIXER SUPPORTS

Parts list	Code
Tightening knob	0701
Tightening knob	0707
White knob (x2)	0728
Plastic caps	45610
Plastic holder for tube	45900
Orange half moon + screws + washer	45900.1
60 mm width bracket	45901
20 mm width bracket	45902
Exterior stop (x2)	45610.S

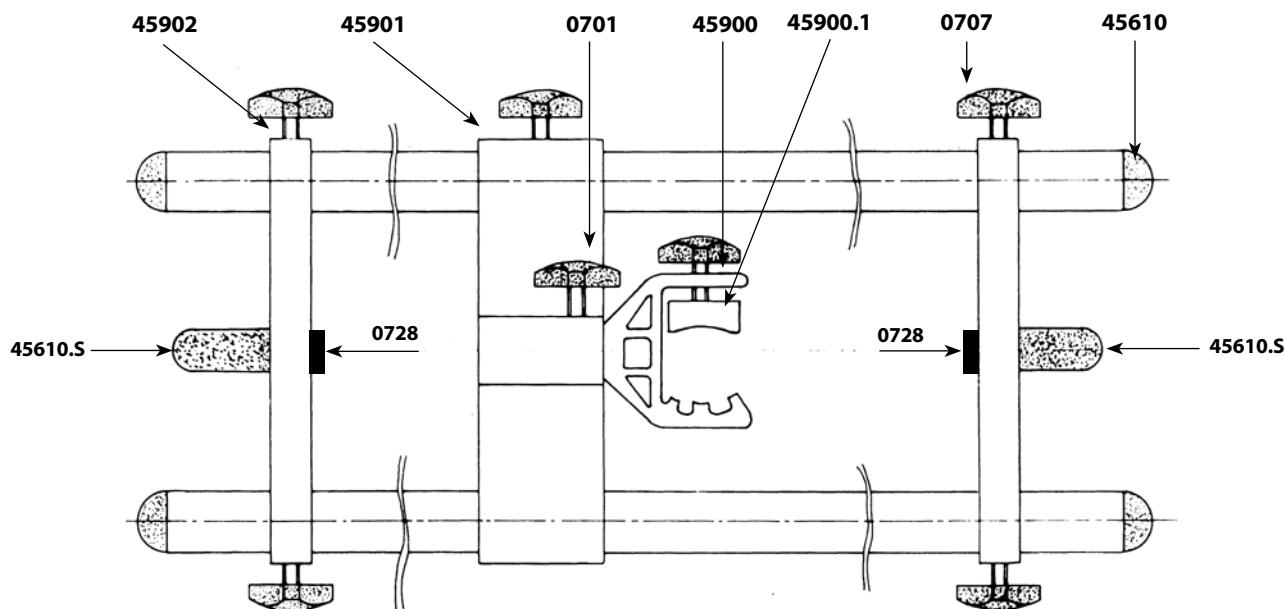

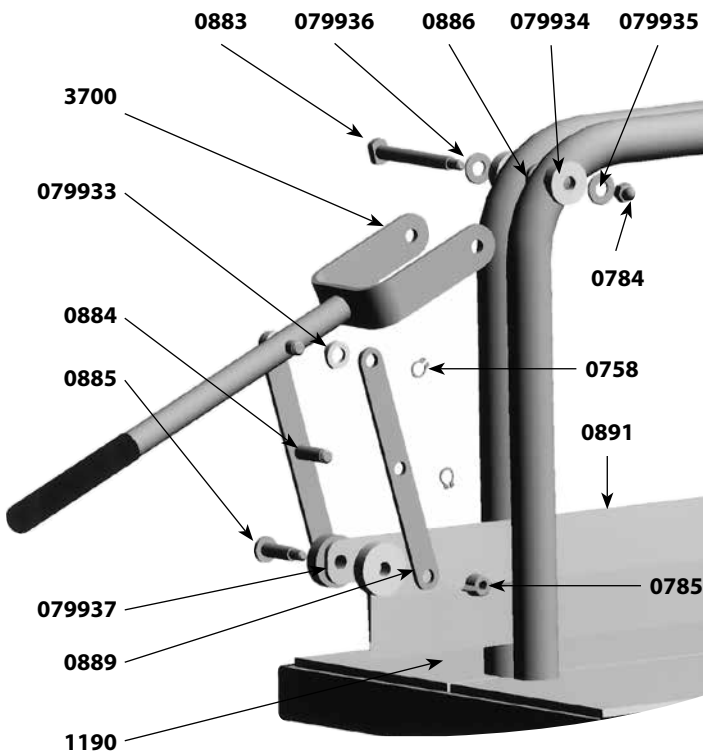

Parts list

Code

Circlips	0758
Forks break nut	0784
Wing nut	0785
Fork axle	0883
Connecting rod axle	0884
Blade axle	0885
Thickness wedge	0886
Connecting rod	0889
Knife blade	0891
Tray	1190
Fork	3700
Connecting rod concave washer	079933
Fork concave washer	079934
Brake nut washer	079935
Fork washer	079936
Blade plastic washer	079937

GM93

Parts list

Code

Motor 230 V	0505
Motor 115 V	0518
Waterproof seal	0620
Lower or upper ball bearing	0621
Transmission belt	0625
Plastic handle	9077
Pole	0899.14
Hood pole	0899.15

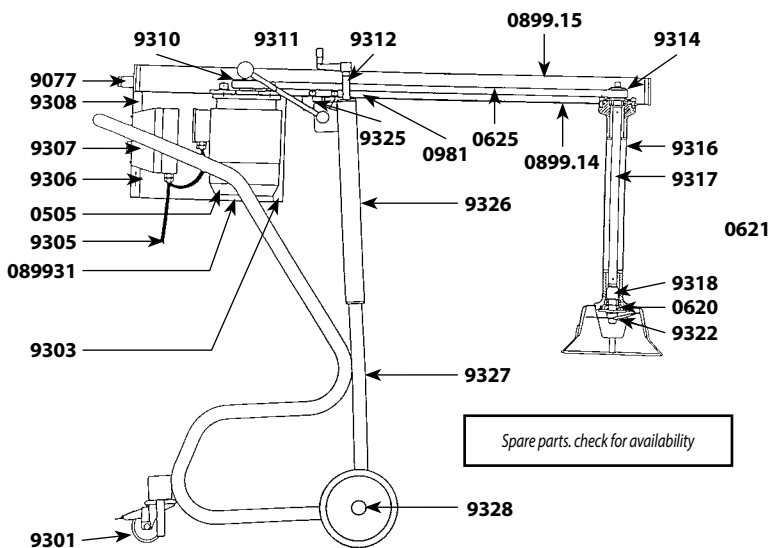

Parts list

Code

Side hood	0899.31
Magnetic switch	0981
Wheel with brake	9301
Front hood	9303
Power cord (380V)	9305
Hood screw w/ plastic washer (unit)	9306
Switch w/ control box	9307
Switch w/ control box	9307.1
Back hood	9308
Motor pulley	9310
Squeezing handle	9311
Level adjustment handle	9312
Shaft pulley	9314
Foot assembly	9316
Main shaft	9317
Lower shaft	9318
Cutter blade	9322
Rubber holders (3)	9325
Fork	9326
Frame	9327
Front wheel	9328

MANUAL SALAD SPINNER SD 99 - SD 92

Parts list SD 99

Code

Outside basket	1801
Inside basket	AC011
Complete cover	1803
Cover w/o small cover. handle & gear	1804
Handle only	1809
Axle for outside basket	1810
Small cover with handle & gear	1812
Bushing + Housing	1814
Small cover (w/o handle & drive gear)	2805
Perforated drive gear	2806
Small gear	2808
Pin	2811
Axle for drive & small gear	2813
Set of gears (2x2806. 2808. 2811)	2815.1
Handle screws (4)	9014
Orange plastic nuts (4)	9014.P
Stainless steel pins (M4x25) (4)	9014.G

Parts list SD 92

Code

Outside basket	2801
Inside basket	AC010
Complete cover	2803
Cover w/o small cover. handle & gear	2804
Small cover (w/o handle & drive gear)	2805
Perforated drive gear	2806
Small gear	2808
Handle only	2809
Axle for outside basket	2810
Pin	2811
Small cover with handle & gear	2812
Axle for drive & small gear	2813
Bushing + Housing	2814
Set of gears (2 X 2806. 2808. 2811)	2815.1
Handle screws (4)	9014
Orange plastic nuts (4)	9014.P
Stainless steel pins (M4x25) (4)	9014.G

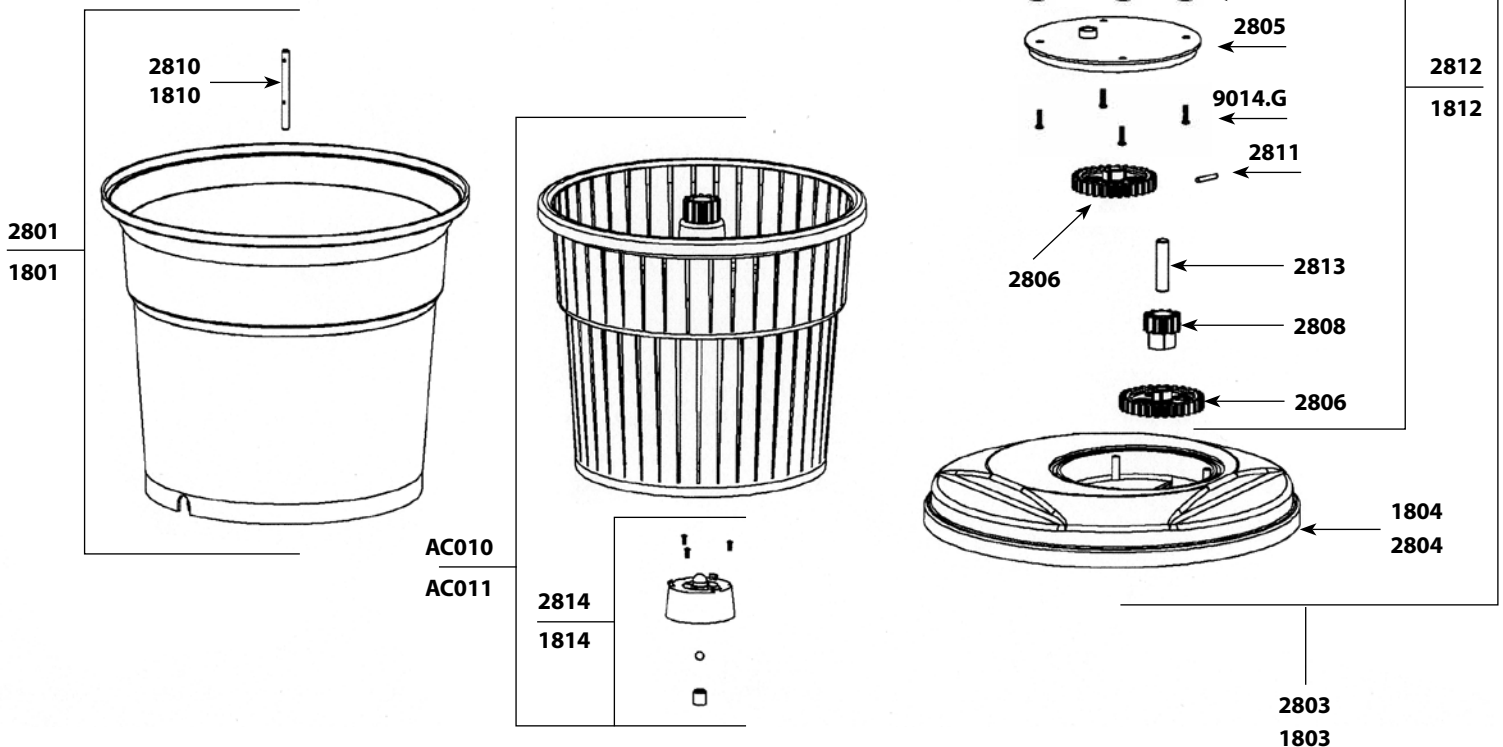

Parts list	Code
Self-lubricating ring	0603
Handle screw (ea)	0720
Handle	0782
Friction washer	0787
Motor housing screws	079917
Motor screws	079929
Switch	0905
Switch protector	0905.1
Strain relief 230V	0950
Strain relief 115V	0950.1
Power cord 230V	0966
Power cord 115V	0967
Outside basket	2801
Inside basket	AC010
Cover w/o small cover. handle & gear	2804
Axle for outside basket	2810
Axle (including screw)	2814
Motor housing 230V (with label)	3001
Motor housing 115V (with label)	3001.1
Big gear	3002
Gear housing protector	3003
Motor 230V (+ capacitor)	3004
Motor 115V (+ capacitor)	3004.1
Motor plate	3005
Small gear	3006
Axle. big gear	3007
Capacitor 230V	3008
Capacitor 115V	3008.1
Complete cover	3010
Complete cover	3010.1
220V Motor shaft	3024
120V Motor shaft	3024.1
Bucket 20L (Inside basket)	P2802

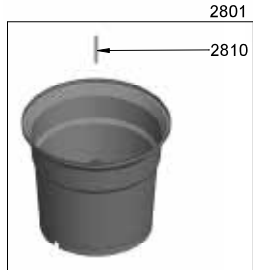
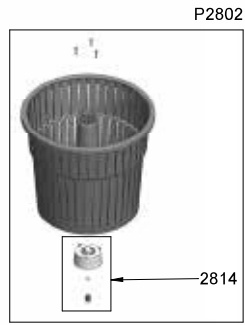
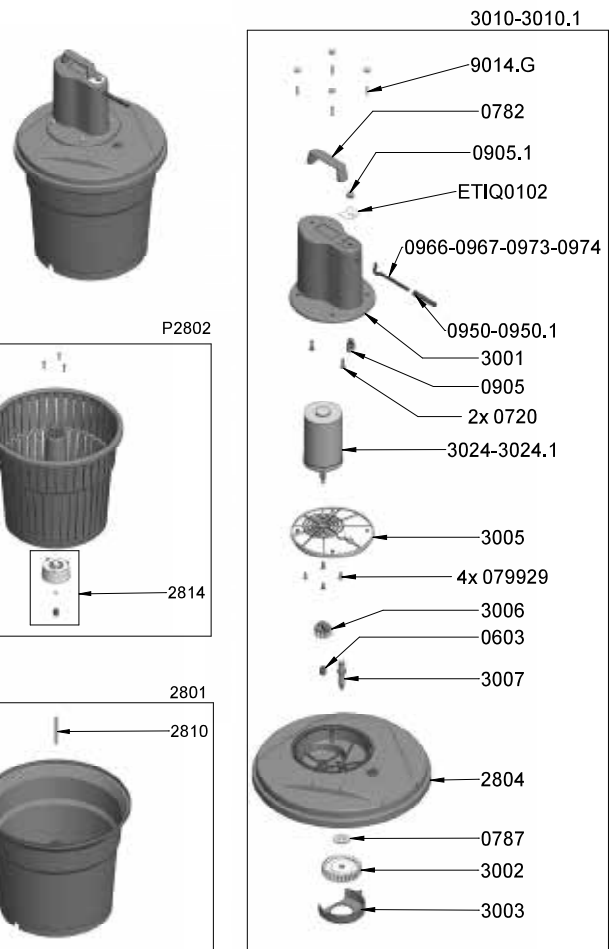
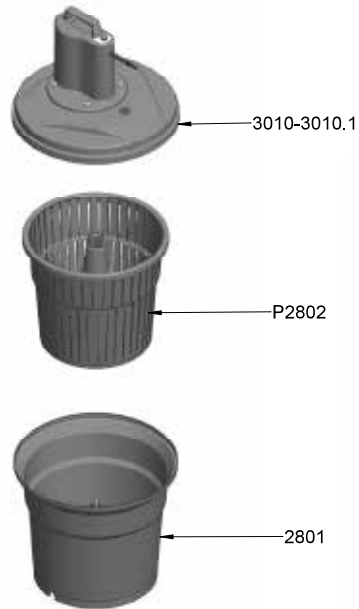

EM 98 ELECTRIC SALAD SPINNER WITH TIMER

Parts list	Code
Self-lubricating ring	0603
Handle screw (ea)	0720
Handle	0782
Friction washer	0787
Motor housing screws	079917
Small gear motor shaft	0831
Strain relief 230 V	0950
Strain relief 115 V	0950.1
Power cord 230 V	0966
Power cord 115 V	0967
Outside basket	2801
Inside basket	AC010
Cover w/o small cover. handle & gear	2804
Axle for outside basket	2810
Axle (including screw)	2814
Motor housing 230V (with label)	3001
Motor housing 115V (with label)	3001.1
Big gear	3002
Gear housing protector	3003
Motor plate	3005
Small gear	3006
Axle. big gear	3007

Parts list	Code
Circuit board with timer	3009
Complete cover 220V	3010.T
Complete cover 120V	3010.T.1
220V Motor shaft	3024
120V Motor shaft	3024.1
Motor screws	079929
Screw M6 x 30	079980
Stainless steel hexagon nut with serrated flange M6	079981
Label with timer	ETIQ0016
Bucket 20L (Inside basket)	P2802

3010T-3010T.1

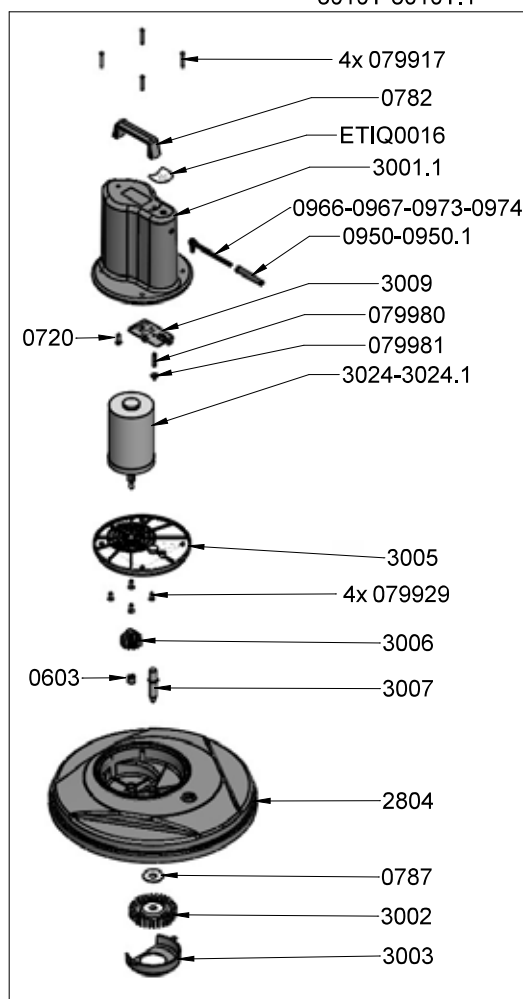

AC010 - P2802

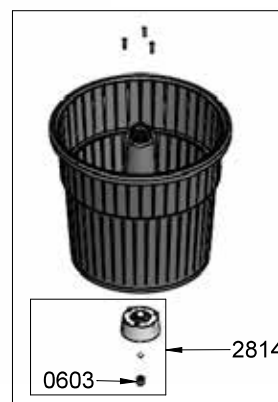

2801

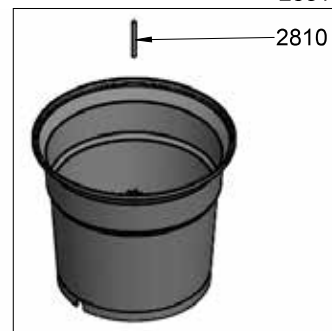

SD MINI MANUAL SALAD SPINNER SEALED COVER

Parts list	Code
O. RING	0652
WATERPROOF SEAL	0667
WATERPROOF SEAL	0669
PIN 3X20	0744
SCREWS TBF 3.9X19	079958
OUTSIDE BASKET + AXLE	5801
DRIVE GEAR	5806
BIG GEAR	5807
SMALL GEAR	5808
OUTSIDE BASKET AXLE	5810
DRIVE & SMALL GEAR AXLE	5813
AXLE	5814
SET OF GEARS	5815.2
CRANK ASSEMBLY	5820
SMALL COVER (WITHOUT HANDLE & DRIVE GEAR)	5821
OUTPUT SMALL GEAR	5822
EQUIPPED COVER	5823
COUPLING SLEEVE	5824
INSIDE BASKET	5825
COMPLETE COVER	5827
HANDLE SCREWS (4)	9014

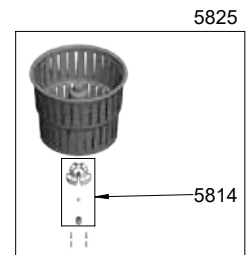
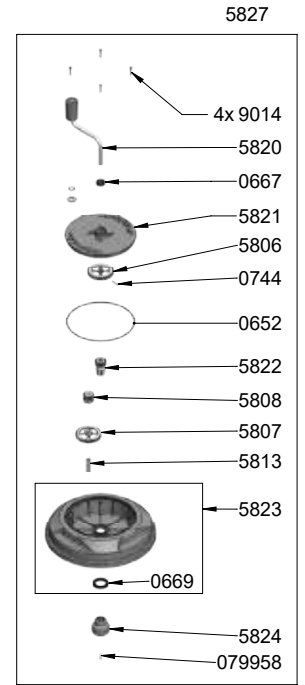
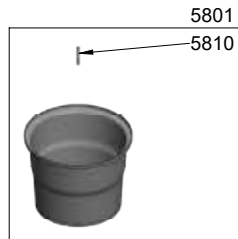
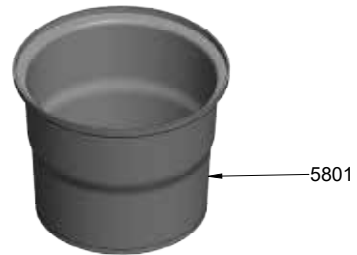
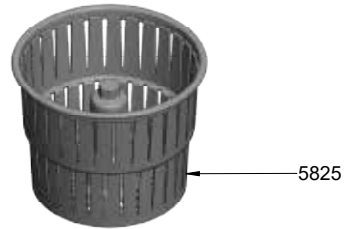
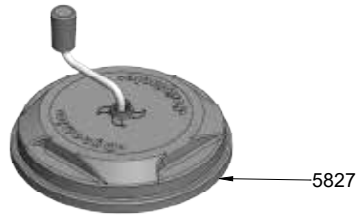

MANUAL SALAD SPINNER SD 92 SC (SEALED COVER)

Parts list	Code
Waterproof seal 14 x 24 x 7	0644
Waterproof seal 25 x 27 x 6	0645
O. Ring	0646
Screws TBF 3.9 x 14 (2)	079958
Outside basket	2801
Perforated drive gear + pin	2806
Small gear	2808
Axle for outside basket	2810
Pin for large gear	2811
Axle for drive & small gear	2813
Axle	2814
Set of gears (2x2806. 2808. 2811. 2822)	2815.2
Handle only	2820
Small cover (w/o handle & drive gear)	2821
Output small gear	2822
Equipped cover (O. Ring + Waterproof seal	2823
Coupling sleeve	2824
Inside basket	2825
Small cover with handle & gear	2826
Complete cover	2827
Plate + screws (x 3)	2828
Screws (4)	9014

2825

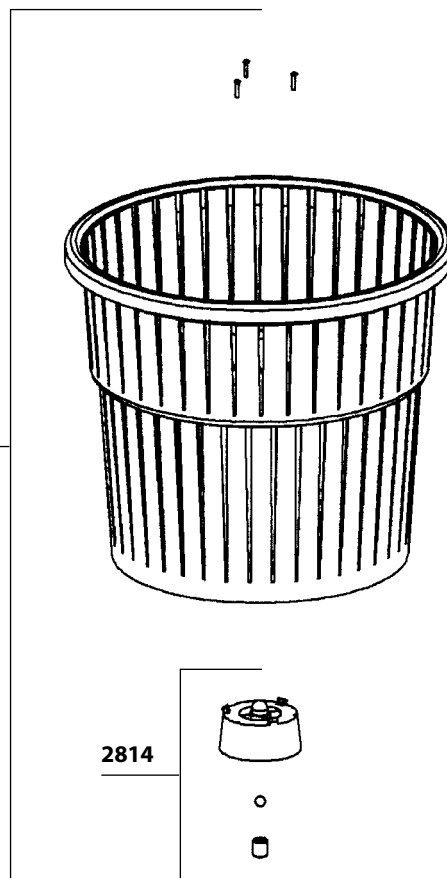

2814

← 2810

2801

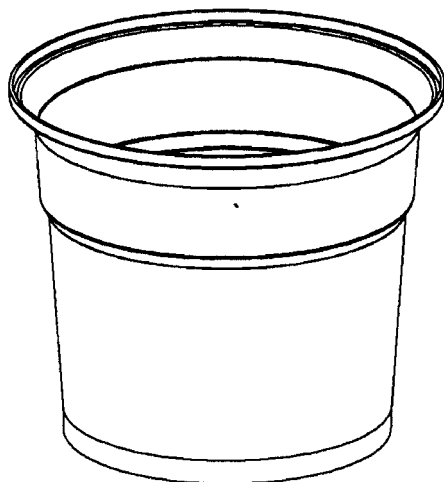

2827

2826

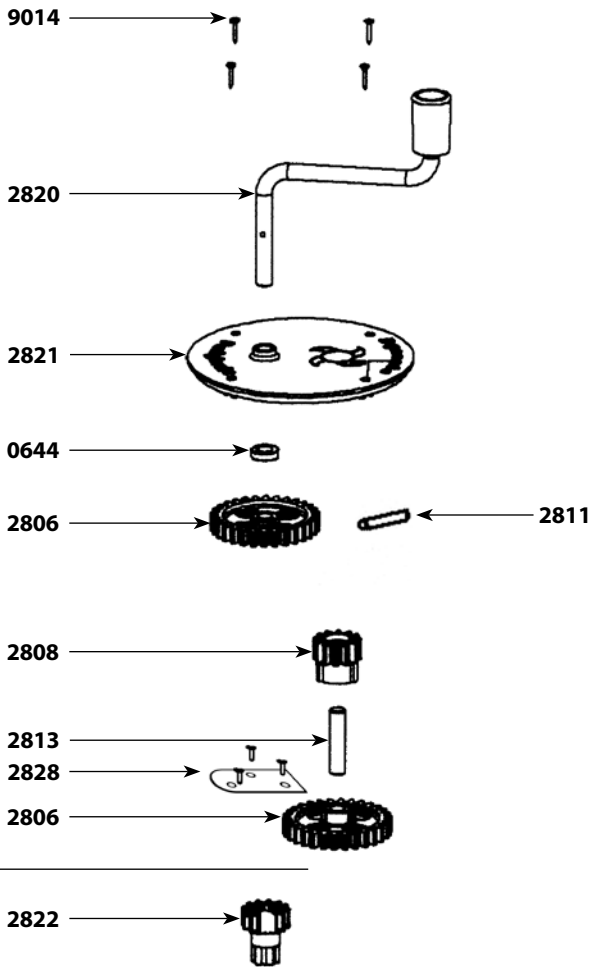

2823

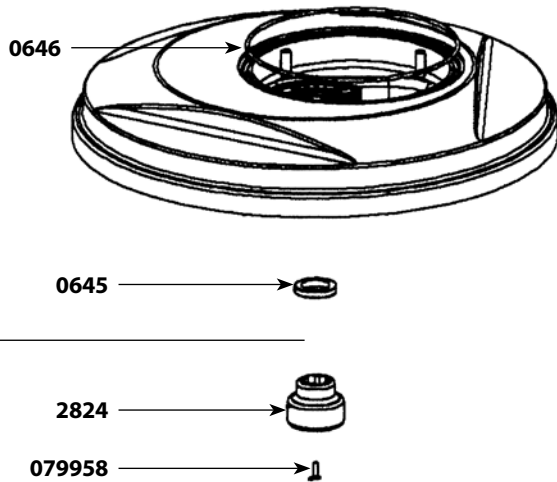

Parts list	Code
Mounting support (unit)	3507
Foot	3508
Suction cup (unit)	3512
Self-lubricating ring (unit)	3523
Circlips 18	3524
Handle pin 4X18	3525
Crank handle and pin	3526
Cone shape gear and pin	3527
Screw on button	3600
Smooth cone shape gear	3607
Plastic ball bearings	3608
Handle (crank) assembly kit	3609
Lower plate with screws (6) + self-lubricating ring	3610
Upper cover casing	3611
Pusher	3612
Blockage sheet + screws (4)	3613
Hollow axle	3614
Roller axle	3615
Support with screws (2)	3616
Roller	3617
Disc holder	3618
Cutter pin	3619
Axle assembly for disc holder	3620

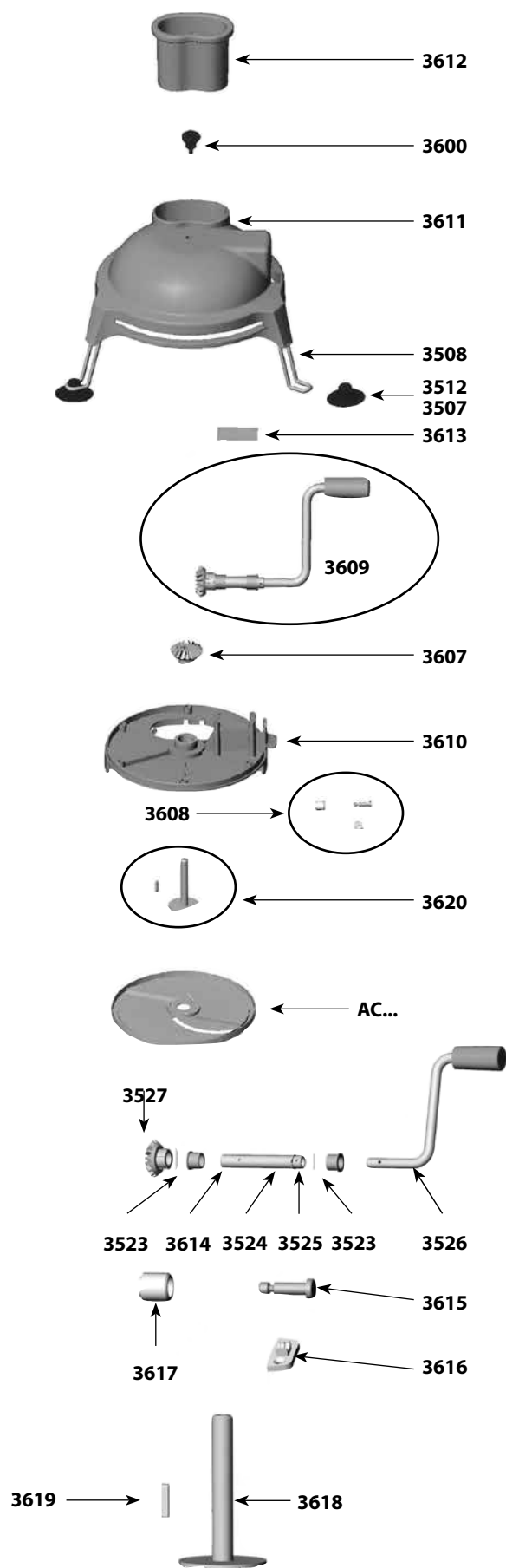

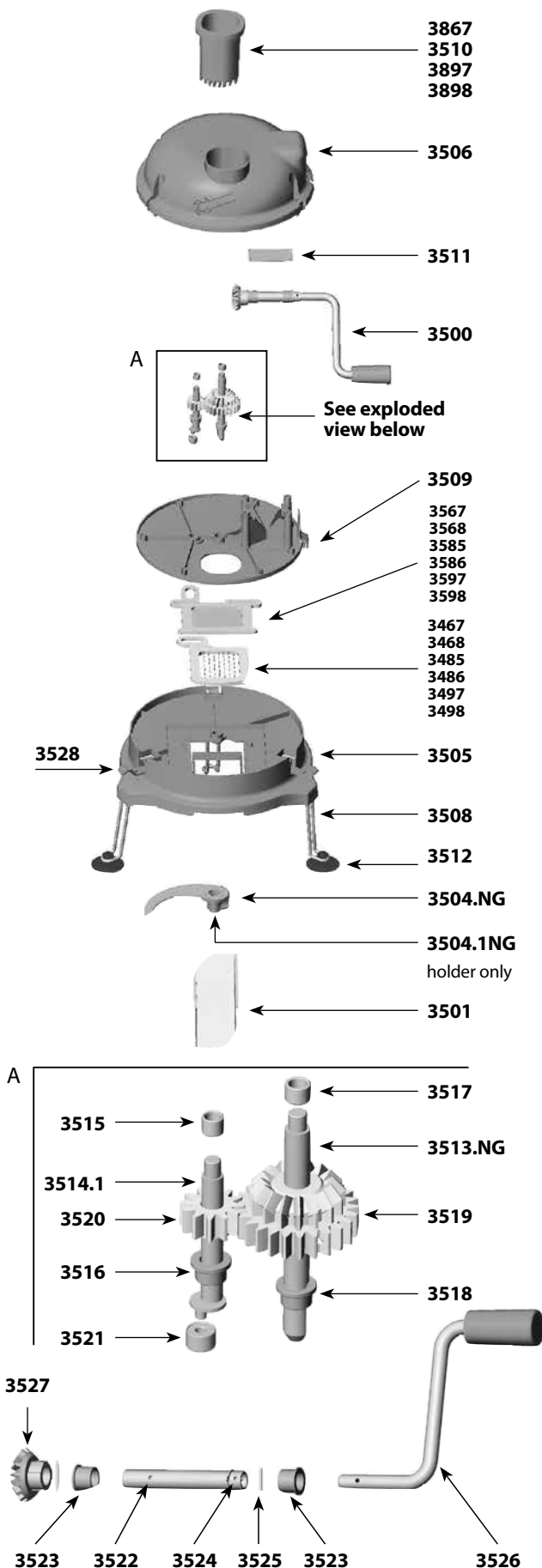

Parts list

Code

Lower grid 1/8	3467
Lower grid 1/2	3468
Lower grid 1/4	3485
Lower grid 3/4	3486
Lower grid 3/8	3497
Lower grid 3/32	3498
Handle assembly kit	3500
Chute	3501
Short cutter blade complete - New generation	3504.NG
Knife plastic holder - New generation	3504.1NG
Bottom unit	3505
Top unit w/ seal	3506
Foot	3508
Intermediate plate assembly	3509
Pusher 1/4 / 3/4	3510
Blockage sheet and screws	3511
Suction cup (unit)	3512
Knife driving axle - New generation	3513.NG
Cutting grid axle + bearings	3514.1
Self-lubricating ring 9/12/10	3515
Self-lubricating ring C12/17/12	3516
Self-lubricating ring 10/14/10	3517
Self-lubricating ring C14/18/14	3518
Double gear and pin	3519
Right gear and pin	3520
Ball bearing (unit)	3521
Hollow axle	3522
Self-lubricating ring (unit)	3523
Circlips 18	3524
Pin	3525
Crank handle and pin	3526
Cone shaped gear and pin	3527
Clips (3)	3528
Upper grid 1/8	3567
Upper grid 1/2	3568
Upper grid 1/4	3585
Upper grid 3/4	3586
Upper grid 3/8	3597
Upper grid 3/32	3598
Pusher 1/8 / 1/2	3867
Pusher 3/8	3897
Pusher 3/32	3898

TERMS AND CONDITIONS

PRICING. All prices are subject to change without notice. Prices do not include freight, handling or delivery charges, air shipment charges or taxes (sales, excise, duties, etc.). The Purchaser shall be responsible for collecting and/or paying any and all such taxes. Such charges may, at Dynamic's sole and exclusive discretion, be prepaid by Dynamic and reimbursed by the Purchaser.

APPLICABLE POLICIES FOR RESALE OF PRODUCTS. All product selling prices are determined at the discretion of authorized distributors with the exception of specific products determined by Dynamic to have Minimum Advertised Pricing («MAP»). Failure to comply with our MAP Policy may affect your status as an authorized distributor. Dynamic reserves the right to take the necessary steps in maintaining our integrity with regards to our pricing.

ORDERS. No minimum orders required. Each order must reference Dynamic's quote (if any), the requested Products, and any other information requested by Dynamic. All orders and transactions are subject to acceptance or cancellation by Dynamic, in Dynamic's sole discretion. Each accepted order will be interpreted as a single agreement, independent of any other orders. All orders must be sent by email at orders@dynamicmixers.com or by fax at 1(877)668-6623.

SHIPPING AND DELIVERY. Prepaid Freight qualifies at \$3000 net (excluding PowerPro) on individual orders shipped to one location. Prepaid Freight Address exclusions are Hawaii, Alaska, Puerto Rico and Canada far North. Additional exclusions may apply. Orders not meeting Prepaid freight criteria are F.O.B. Memphis, TN USA or F.O.B. Montreal, QC. Canada. A fee may apply on 'Drop Ship' orders. Shipping specifics and delivery dates advised are estimates only and Dynamic is not responsible on variances. Dynamic reserves the right to refuse or cancel any order. On occasion, products contained in a single order may ship separately. Dynamic reserves the right to choose the carrier on specific orders. Freight charges are based on product weight & destination zip code or postal code. Product damage or loss incurred during shipment is the sole responsibility of the product purchaser. The purchaser must notify Dynamic regarding any product inconsistencies within 7 days of receipt of order including damages and shortages.

RETURNS. Returns cannot be accepted without a Return Authorization number issued by Dynamic and a return request must be submitted within seven (7) days of invoice date. Product returns must be in original packaging and unopened. Damaged and/or used Products will not be accepted. A 25% restocking charge will apply on all returns. Products deemed «Special Order» cannot be returned.

INVOICING AND PAYMENT. Dynamic may invoice parts of an order separately, or may invoice purchases of Products in one invoice. Invoices are due and payable within the time period noted on the Purchaser's invoice. All Products sold remain the exclusive property of Dynamic until invoice is paid in full.

WARRANTY. Dynamic will guarantee all new Products to be free from defects in materials and workmanship. Electric Products include a one (1) year parts and labor carry in bench warranty with the exception of component replacements necessary through regular "wear and tear". Manual Products include a one (1) year limited parts warranty. Warranty is valid, providing the Products have been used in accordance with Dynamic's operating recommendations and guidelines. Dynamic or any authorized service center will repair or replace, at Dynamic's discretion and after examination, any or all manufacturer's defective parts during the warranty period. Any damage caused by improper use, abuse, dropping, or similar accidental damage resulting in breakage will render the warranty null and void. During the warranty period, only Dynamic or one of its authorized service centers may perform evaluations or repairs to Products. Warranty will be void on any equipment which has been dismantled or tampered with during the warranty period if this has been done by unauthorized centers or personnel.

DISCLAIMER. Specifics contained herein with regards to Product text and/or Product images may change without notice.

USA

1320 ROUTE 9 #1352
CHAMPLAIN, NY - 12919
PHONE (800) 267-7794
INFO@DYNAMICMIXERS.COM
DYNAMICMIXERSUSA.COM



A NADIA GROUP COMPANY

 facebook.com/dynamicmixers

 [@dynamicmixers](https://instagram.com/dynamicmixers)